

Air terminals are the most noise sensitive of all HVAC products since they are almost always mounted in or directly over occupied spaces. They usually determine the residual background noise level from 125 Hz to 2,000 Hz. The term "Air Terminals" has historically been used to describe a number of devices which control airflows into occupied spaces at the zone (or individual temperature control area) level. There are two types: those that control the amount of airflow to a temperature zone (Air Control Units, ACUs, or more commonly "Boxes"), and those that distribute or collect the flow of air (Grilles & Diffusers, GRDs). On some occasions, the two functions are combined. As these two elements are the final components in many built-up air delivery systems and those closest to the building occupants, both are critical components in the acoustical design of a space. There is also a critical interplay between acoustics and the primary function of these devices; providing a proper quantity of well mixed air to the building occupants. Before discussing types of devices, we must have an understanding of some issues regarding sound levels in occupied spaces.

The sound level in an occupied space can be measured directly with a sound level meter, or estimated from published sound power after accounting for room volume and other acoustical factors. Sound level meters measure the sound pressure level at the microphone location. Estimation techniques calculate sound pressure level at a specified point in an occupied space. Measured sound pressure levels in frequency bands can then be plotted and analyzed, and compared with established criteria for room sound levels.

Sound power cannot be measured directly, (except using special Acoustic Intensity techniques), and is a measure of the acoustical energy created

by a source. It is normally determined in special facilities and reported for devices under stated conditions. Sound Power Level (Lw) values for Air Terminal devices are usually reported as the sound power level in each of several octave bands with center frequencies as shown in **Table 11**. Sound Power Levels are given in decibels (dB) referenced to a base power in watts, typically  $10^{-12}$  watts. Sound power levels can also be reported for full or  $\frac{1}{3}$  octave bands, but usually as full octave bands, unless pure tones (narrow bands significantly louder than adjacent adjacent bands) are present.

## NOISE CRITERIA (NC)

Sound Pressure Levels (Lp) are measured directly by sound level meters at one or more points in a room. They reference a pressure rather than a power. A product's estimated Sound Pressure Level (Lp) performance curve is obtained by subtracting space (or other appropriate) sound attenuation effects from the unit sound power (Lw). Currently, most Air Outlet and Inlets (GRDs) sound performance is reported by subtracting a 10 dB attenuation from all octave band sound power levels, and determining the NC rating. This room effect approximates a 3,000 cu. ft. room, 10 ft. from the source for VAV boxes, which peak in lower frequencies, and a 2,500 cu. ft. room 7 ft. from a diffuser, which typically peaks @ 1000 Hz. (This is defined in the AHRI Standard 885 space effect calculation described later in this section). NC curves were developed to represent lines of equal hearing perception in all bands and at varying sound levels. Most air terminal products are currently specified and reported as single number NC ratings.

Table 11. Octave Band Designations

Center Frequency	63	125	250	500	1000	2000	4000	8000
Band Designation	1	2	3	4	5	6	7	8

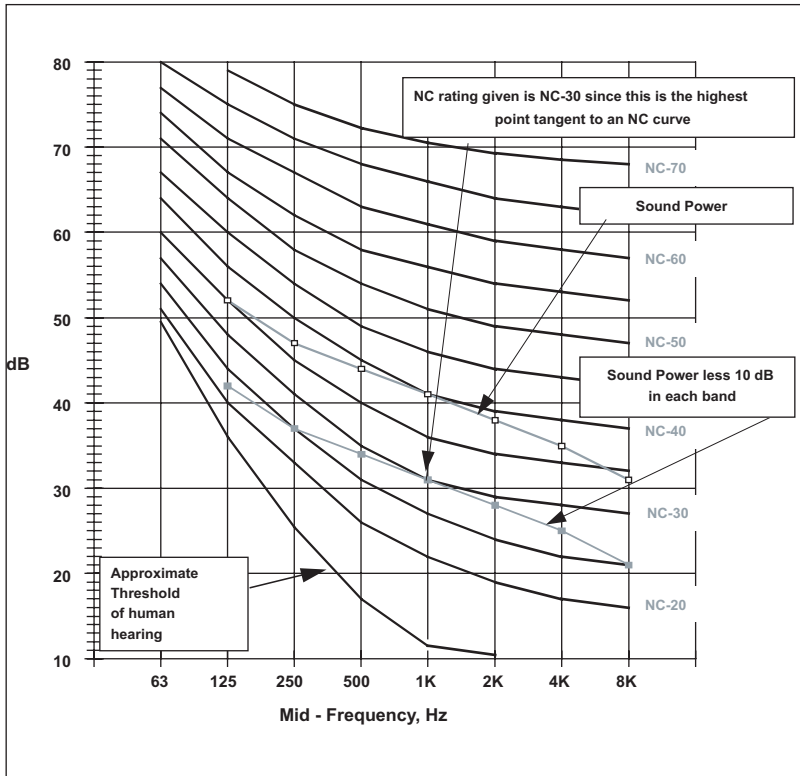

Figure 127. Typical NC Graph for a Diffuser

Room	Hz	63	125	250	500	1000	2000	4000	8000
Volume	Band	1	2	3	4	5	6	7	8
2000 CuFt	@ 5ft	-4	-5	-6	-7	-7	-8	-9	-10
	@ 10ft	-7	-8	-9	-10	-11	-11	-12	-13
	@ 15ft	-9	-10	-10	-11	-12	-13	-14	-15
2500 CuFt	@ 5ft	-4	-5	-6	-7	-8	-9	-10	-11
	@ 10ft	-7	-8	-9	-10	-11	-12	-13	-14
	@ 15ft	-9	-10	-11	-12	-13	-14	-15	-15
3000 CuFt	@ 5ft	-5	-6	-7	-7	-8	-9	-10	-11
	@ 10ft	-8	-9	-10	-10	-11	-12	-13	-14
	@ 15ft	-10	-10	-11	-12	-13	-14	-15	-16
5000 CuFt	@ 5ft	-6	-7	-8	-9	-9	-10	-11	-12
	@ 10ft	-9	-10	-11	-12	-12	-13	-14	-15
	@ 15ft	-11	-12	-12	-13	-14	-15	-16	-17

Table 12. Space Effect (AHRI 885 and ASHRAE)

In this example, the outlet Lp spectrum does not exceed the NC curve of 30 in any of the eight octave bands and is thus referred to as meeting an NC-30 criteria and specification.

It should be noted that while this spectra meets NC-30, if the critical band resulted in an NC-33, most building occupants would not be able to discern the difference.

The use of a 10 dB “room effect” as used in this example, while in common practice and accepted for many years, is not as accurate a prediction as is possible using newer techniques. The ASHRAE Handbook and AHRI Standard 885 present an equation for determining the “space effect” based on both room volume and the distance from the observer to a point sound source.

$$\text{Space Effect} = (25) - 10 \text{ Log (ft.)} \\ - 5 \text{ Log (cu. ft.)} \\ - 3 \text{ Log (Hz)}$$

Where:

- ft. = Distance from observer to source
- cu. ft. = Room volume
- Hz = Octave band center frequency

This yields a range of deductions which differ in each octave band, as shown in **Table 12**.

The 10 dB room effect which has been traditionally used for diffuser sound ratings, which typically peak in the 5th band, can be considered to be equivalent to a room about 2,500 cu. ft. in size, with the observer located about 7 ft. from the source.

With VAV terminals, which peak in lower bands, the “10 dB” room size is larger, or the distance is greater.

NC ratings have been common in specifications for a number of years, with an NC-35 being the most common requirement. While NC is a great improvement over previous single number ratings, including Sones, Bels, and dBA requirements, it gives little indication of the “quality” of the sound. A more comprehensive method, RC, has been proposed; while a good analysis tool, RC is a very poor design tool.

Room Criteria (RC) is based on ASHRAE sponsored studies of preference and requirements for speech privacy, along with ratings for “Acoustical Quality.” RC ratings contain both a numerical value and a letter “Quality” rating. The RC numerical rating is simply the arithmetic average of the sound pressure level in the 500, 1,000 and 2,000 Hz octave bands, which is the speech interference level (SIL). These are the frequencies that affect speech communication privacy and impairment. Studies show that an RC between 35 and 45 will usually provide speech privacy in open-plan offices, while a value below 35 does not. Above RC-45, the sound is likely to interfere with speech communication.

In addition to the numerical SIL portion of the RC method, there is a “Quality” portion of the RC rating which involves an analysis of potential low and high frequency annoyance. The goals of acoustical quality are described in **Table 13**.

Recommended NC and RC goals for various space applications, given in the current ASHRAE Handbook, are shown in the table to the right.

Table 13. ASHRAE Defined Acoustic Quality

Not too quiet	Don't destroy acoustic privacy
Not too loud	Avoid hearing damage Don't interfere with speech
Not to annoying	No rumble, No hiss No identifiable machinery sounds, No time modulation
Not to be felt	No feel able wall vibration

Table 14. NC / RC Guidelines

Space	RC	NC
<b>Occupancy</b>		
Private residence	RC 25-30(N)	NC 25-30
Apartments	RC 30-35(N)	NC 30-35
<b>Hotels/Motels</b>		
Individual rooms or suites	RC 30-35(N)	NC 30-35
Halls, corridors, lobbies	RC 35-40(N)	NC 35-40
Service / support areas	RC 40-45(N)	NC 40-45
<b>Offices</b>		
Executive	RC 25-30(N)	NC 25-30
Conference Rooms	RC 25-30(N)	NC 25-30
Private	RC 30-35(N)	NC 30-35
Open plan areas	RC 35-40(N)	NC 35-40
Public circulation	RC 40-45(N)	NC 40-45
<b>Hospitals and clinics</b>		
Private rooms	RC 25-30(N)	NC 25-30
Wards	RC 30-35(N)	NC 30-35
Operating rooms	RC 25-30(N)	NC 25-30
Laboratories	RC 35-40(N)	NC 35-40
Corridors	RC 30-35(N)	NC 30-35
Public areas	RC 35-40(N)	NC 35-40
Churches	RC 30-35(N)	NC 30-35
<b>Schools</b>		
Lecture and classrooms	RC 25-30(N)	NC 25-30
Open-plan classrooms	RC 35-40(N)	NC 35-40

The Four "Quality" letter designations currently in use are:

- R Rumble
- H Hiss
- V Vibration (acoustically induced)
- N Neutral

These letters are determined by analyzing the low and high frequency spectra compared to a line drawn with a -5 dB slope per band through the numerical RC point @ 1,000 Hz. This establishes the SIL (Speech Interference Level) line. Lines of -5 dB slope create the RC chart, shown in (Figure 128).

Also shown in (Figure 128) are areas of rumble (B) and vibration (A), as well as a threshold of audibility. Note that the RC chart goes well below the 63 Hz lower cutoff of the NC chart, as these low frequency sound levels have been discovered to be a major source of discomfort to occupants.

If the sound spectrum being analyzed exceeds a line drawn parallel to the SIL line plus 3 dB in the higher frequencies (> 2,000 Hz), the "hiss roof," then it is declared to be "Hissy" and gets an "H" designation.

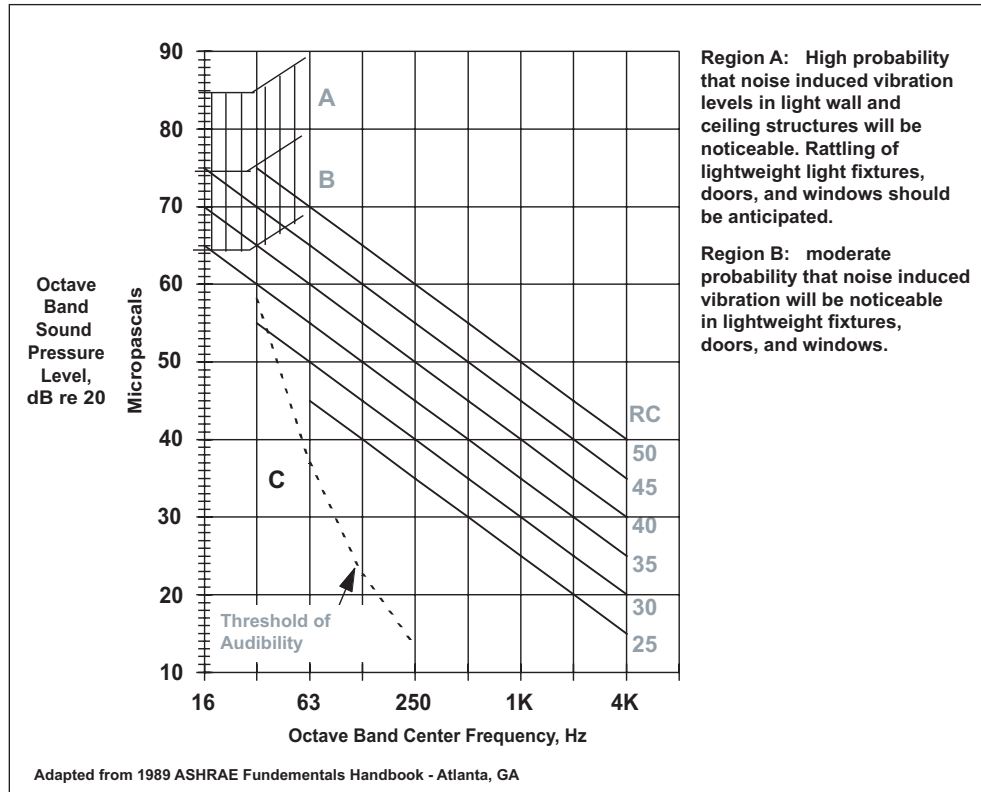

Figure 128. Room Criteria (RC) Curves

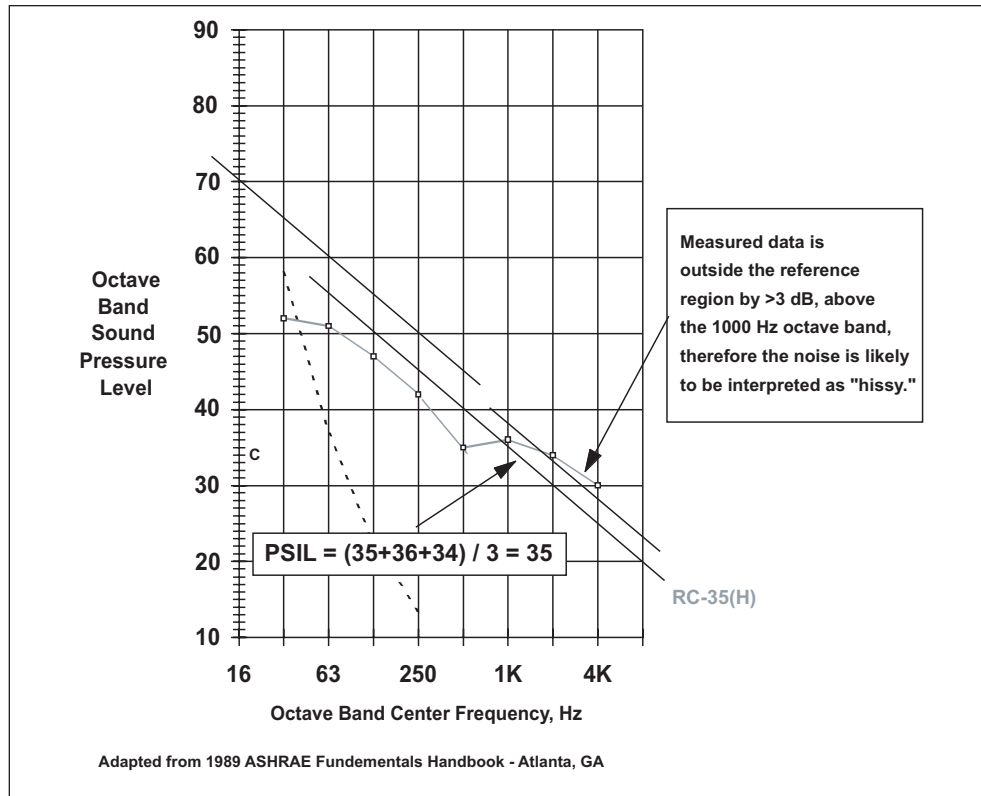

Figure 129. Hissy Spectrum

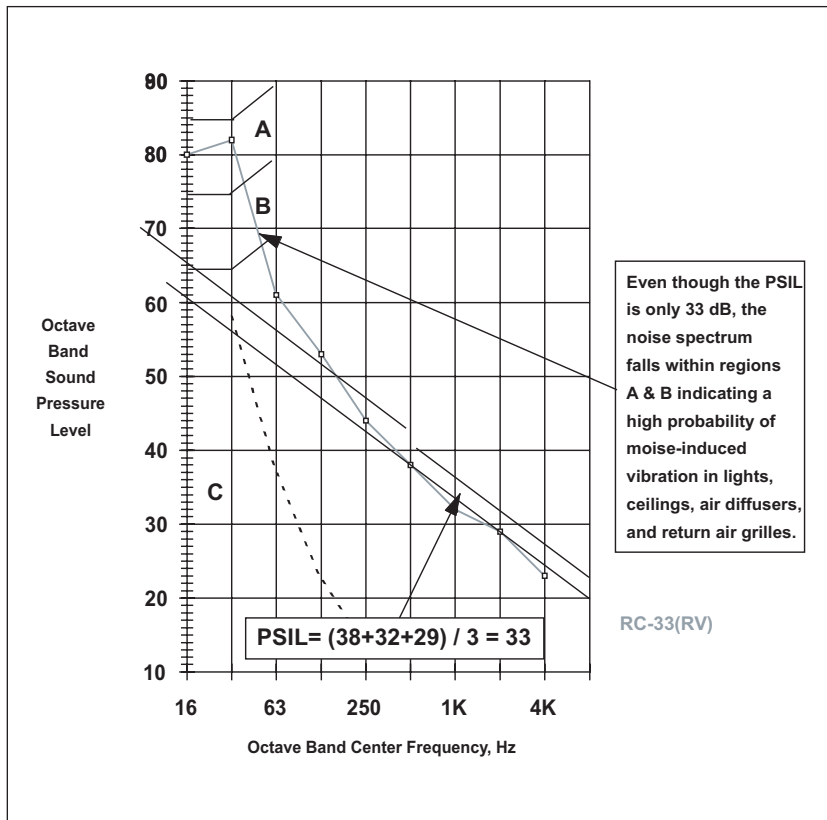

Figure 130. Rumble and Induced Vibration (RV) Spectrum

If the plotted spectra exceed a +5 dB Rumble roof in the lower frequencies, it gets an "R" (Rumble) Rating. Finally, if the sound spectrum enters the "A" or "B" zones in the very low frequencies shown on the RC graphs, it warrants a "V" for possible wall or furniture vibration induced by acoustical energy in low frequencies. The B region may be characterized as "Be Careful" where one may have complaints, but the "A" region is "Awful", and complaints should be expected. This is an example of an RV spectrum.

When room sound levels are analyzed using RC curves, air diffusers tend to give the same ratings as they do in an NC analysis. Boxes, on the other hand, which are typically predominant in lower frequency sound and often characterized as "Roar" (250-500 Hz), often yield RC values lower than NC, but with an "R" classification.

### AIR TERMINAL SOUND ISSUES

Sound is an important design criterion in the application of air terminals. In the context of the total building environment, comfort cannot be achieved with excessive sound or noise levels. By definition, sound is a change in pressure for a medium, such as air. This change in pressure involves a radiation of energy. Energy is used in the generation of sound and this energy is radiated from a source.

All sound has a source and travels down a path to a receiver. Air terminals are one source of sound in a mechanical system. The path for sound emanating from the air terminal is through the plenum or down the duct into the conditioned space where it reaches the occupant or receiver.

Mechanical system designers should not be concerned so much with sound, but rather with noise. Noise can be thought of as unwanted or excessive sound. Good design practice dictates that a designer establish the acceptable noise for the occupied space and then determine the selection criteria for the mechanical system components.

In any application, both radiated and discharge sound should be considered. Radiated sound "breaks out" from the terminal casing or induction port and travels through the plenum and ceiling to enter the occupied space. Discharge sound travels out the discharge of the terminal through the duct work and outlet to enter the occupied space.

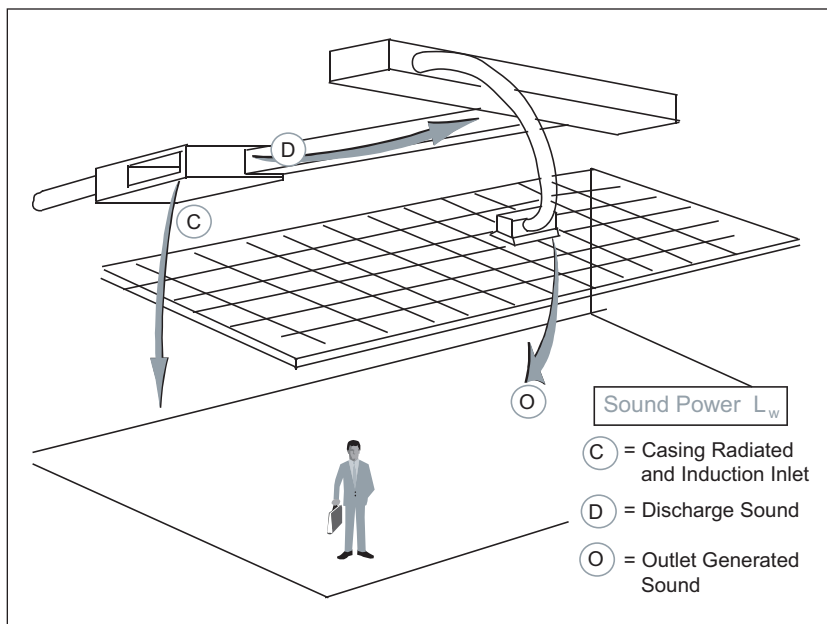

Figure 131. Typical Sound Sources for Fan Terminal System

AHRI Standard 885, Procedure for Estimating Occupied Space Sound Levels in the Application of Air Terminal and Air Outlets, provides the most current application factors for converting rated sound power to a predicted room sound pressure level. This standard is the basis by which most air terminal manufacturers convert sound power, as measured in reverberant rooms per ASHRAE Standard 130 and rated in accordance with AHRI Standard 880, to a predicted room sound pressure level. The standard provides a number of equations and tables available elsewhere, but puts them all in one document, and includes some unique tables as well. It also includes examples and diagrams to make the process easier to use. The most important of those are included here.

### ENVIRONMENTAL ADJUSTMENT FACTOR

In order to use the AHRI 885 Standard, sound power must be corrected for differences between reverberant room and free field calibrations when AHRI 880 sound power is the base. This Environmental Adjustment Factor is listed in AHRI Standard 885.

According to AHRI Standard 885, an Environmental Adjustment Factor must be applied to manufacturers' data if the sound power data has been taken under a free field RSS (reference sound source). According to AHRI, this is "necessary because at low frequencies, all real occupied spaces behave acoustically more like reverberant rooms than open spaces (free field)." In other words, manufacturers' sound power data which is based on ILG/RSS with a free field calibration must be adjusted to match actual operating conditions found in the field. This applies to Titus and other participants in the AHRI Standard 880 Certification program. For data rated per AHRI Standard 880, the environmental adjustment factor must be subtracted from the manufacturers' sound power level data in order to use the adjustments provided in AHRI Standard 885.

Table 15. Environmental Adjustment Factor

Octave Band	2	3	4	5	6	7	8
Env Factor	2	1	0	0	0	0	0

### RADIATED SOUND POWER LEVELS

To determine the maximum allowable radiated sound power levels for a project, the attenuation from the ceiling / space effect must be added to the desired room sound pressure for each octave band.

### CEILING / SPACE EFFECT

AHRI Standard 885 combines the effect of the absorption of the ceiling tile, plenum absorption and room absorption into the Ceiling / Space Effect. Experience has shown that the Sound Transmission Class (STC) rating for ceiling tiles, which is based on a two room pair test, is not well correlated with observed data for a noise source located above a ceiling. The AHRI Standard 885 Ceiling / Space Effect table D14 **Table 16** is derived from a number of manufacturers' observations and is only found in the AHRI Standard. This table assumes that the plenum space is at least 3 ft. deep, is over 30 ft. wide or lined with insulation and that there are no penetrations directly under the unit.

From the AHRI Standard, the following attenuation values, or transfer functions, should be used for the Ceiling / Space Effect:

$$L_w \text{ RAD} = L_p + S + P / C + \text{Env}$$

where:

- $L_w \text{ RAD}$  = Radiated Sound Power Level
- $L_p$  = Sound Pressure Level
- $S$  = Space Effect
- $P/C$  = Plenum/Ceiling Effect
- $\text{Env}$  = Environmental Effect

Once the Ceiling / Space Effect has been determined, they are added to the sound pressure level to determine the maximum acceptable sound power levels. This must be done for each octave band.

Table 16. Ceiling / Space Effect (Table D14, AHRI Standard 885)

Frequency	125	250	500	1K	2K	4K
Octave Band	2	3	4	5	6	7
Mineral Fiber Tile Ceiling <sup>5/8"</sup>	16	18	20	26	31	36
Glass Fiber Tile Ceiling <sup>5/8"</sup>	16	15	17	17	18	19
Solid Gypsum Board <sup>5/8"</sup>	23	27	27	29	29	30



Discharge sound (sometimes called airborne sound) is the sound that travels down the duct and discharges into the room along with the conditioned air. The procedure for determining the maximum acceptable discharge sound power levels requires the addition of the **space effect, end reflection, duct insertion, flow division** (or branch power division) and **elbow and tees** to the maximum acceptable room sound pressure levels. If more than one outlet supplies air to a room, separate evaluations should occur for each discharge path. This is done for each octave band.

**Space Effect.** The discharge sound space effect is determined in the same manner as the radiated sound space effect. The sound source in this case might be the outlet (i.e., grille or diffuser) supplying air to the space, or may be sound from an upstream noise source (damper or fan) which passes through the outlets, or a sum of both **Table 12**.

**End Reflection.** When the area across the airstream expands suddenly as the duct work terminates or ends at the outlet to the occupied space, a significant amount of low frequency sound is reflected back into the duct work. This is called end reflection. The amount of end reflection varies based on the inlet size and type of duct.

**Duct Insertion Loss.** The addition of lined duct work results in significant attenuation of higher frequency sound. The amount of attenuation varies with duct size and lining thickness. AHRI Standard 885 contains several tables helpful in determining the appropriate attenuation values. Each section of duct work inserted downstream of the terminal must be evaluated. For example, one might have separate duct insertion **Table 17. End Reflection dB (Table D13, AHRI Standard 885)**

Eq. Dia. or Duct Width	Octave Band							
	1	2	3	4	5	6	7	8
6"	18	12	7	3	1	0	0	0
8"	16	10	5	2	1	0	0	0
10"	14	8	4	1	0	0	0	0
12"	12	7	3	1	0	0	0	0
16"	10	5	2	1	0	0	0	0
24"	7	3	1	0	0	0	0	0

attenuation values for straight lined discharge duct, branch duct (if lined) and flex duct from the branch to the outlet. The AHRI Standard, as well as the ASHRAE Handbook, provide tables of insertion loss per foot of duct based on inside duct dimensions.

While lined duct factors are available in both ASHRAE and AHRI documents, flexible duct insertion loss data is available only from manufacturers or as found in the AHRI Standard 885. **Table 20** is the flexible duct insertion loss data from AHRI Standard 885.

Two tables are provided here for rectangular and round lined duct from the AHRI Standard.

Table 18. Round 1-inch Lined Spiral Duct, dB / ft. (Table D7, AHRI Standard 885)

Duct Diameter	Octave Band					
	2	3	4	5	6	7
6"	0.59	0.93	1.53	2.17	2.31	2.04
12"	0.46	0.81	1.45	2.18	1.91	1.48
24"	0.25	0.57	1.28	1.71	1.24	0.85
48"	0	0.18	0.63	0.26	0.34	0.45

Table 19. Rectangular, 1-inch Lined Duct, dB / ft. (Table D8, AHRI Standard 885)

Duct Dimension	Octave Band					
	2	3	4	5	6	7
6" x 6"	0.6	1.5	2.7	5.8	7.4	4.3
12" x 12"	0.4	0.8	1.9	4	4.1	2.8
24" x 24"	0.2	0.5	1.4	2.8	2.2	1.8
48" x 48"	0.1	0.3	1	2	1.2	1.2

Table 20. Flexible Duct Insertion Loss, dB (Table D9, AHRI Standard 885)

Duct Diameter Inches	Duct Length Feet	Insertion Loss, dB Octave Bands					
		2	3	4	5	6	7
4	10	9	9	27	32	38	24
	5	6	5	16	23	27	18
	3	4	4	12	19	23	15
5	10	9	12	28	32	37	23
	5	5	7	17	22	25	16
	3	4	5	13	18	21	13
6	10	9	15	28	32	35	22
	5	5	9	18	21	24	15
	3	4	6	13	16	19	11
8	10	9	18	29	31	32	20
	5	5	10	18	19	21	12
	3	3	7	14	14	16	8
10	10	8	19	28	30	29	18
	5	4	11	18	17	18	9
	3	3	7	14	11	13	6
12	10	7	17	26	28	26	15
	5	3	9	16	15	15	7
	3	2	6	12	9	11	4
14	10	5	13	23	25	23	12
	5	2	7	14	13	13	6
	3	1	4	10	8	9	4
16	10	3	7	19	23	20	8
	5	1	2	11	11	11	5
	3	0	0	8	7	8	4

**Flow Division.** When the airstream is divided, the sound carried in each downstream branch is less than the sound upstream of the branch take-off. This shows the percent of total airflow carried by the branch. The appropriate level of attenuation can then be determined from Table 21.

**Elbows and Tees.** A certain amount of attenuation of higher frequency

Table 21. Duct Splits, dB

% of Total Air Flow	5	10	15	20	30	40	50	60
Attenuation	31	10	8	7	5	4	3	1

sound is gained when an airstream enters an elbow or tee duct connection. If the elbow is round and unlined, the attenuation is considered by AHRI Standard 885 to be negligible. Attenuation of rectangular tees is determined by treating the tee as two elbows placed side by side.

Once all of the attenuation factors have been determined, they are added to the sound pressure level to determine the maximum acceptable sound power levels. This must be done for each octave band, and again the Environmental Adjustment factor must be added.

$$LW\ DIS = L_p + S + ER + I + D + T/E + Env$$

where:

- LW DIS = Discharge Sound Power Level
- $L_p$  = Sound Pressure Level
- S = Space Effect
- ER = End Reflection
- I = Duct Insertion
- D = Flow Division
- T/E = Tee/Elbow
- Env = Environmental Factor

Approximate Attenuation of 90° Elbows without Turning Vanes

Table 22. Lined Rectangular, dB (Table D12, AHRI Standard 885)

Duct Width	Octave Band					
	2	3	4	5	6	7
5-10	0	0	1	6	11	10
11-20	1	6	6	11	10	10
21-40	6	6	11	10	10	10
41-80	6	11	10	10	10	10

Table 23. Circular with Lining Ahead or Behind Elbow, dB (Table D10, AHRI Standard 885)

Duct Width	Octave Band					
	2	3	4	5	6	7
5-10	0	0	1	2	3	3
11-20	1	2	2	3	3	3
21-40	2	2	3	3	3	3
41-80	2	3	3	3	3	3

ACCEPTABLE TOTAL SOUND IN A SPACE

Once the Radiated and Discharge sound pressure paths and effects are known, the resulting room sound level can be evaluated. Other factors may play a part in determining the final room sound levels. All these factors must be included to achieve an accurate prediction or analysis. The results may be very complex.

In the example here, many paths are shown. In practice, only a couple are significant, but changes in designs may make a one time insignificant path become predominant. For example, should duct lining be eliminated and no flex duct employed, discharge sound may be much more important than radiated, the usual acoustical problem. Poor duct design may cause duct breakout to be the highest sound heard in the space.

The AHRI Standard 885 Standard provides guidance on all the possible paths. Not shown here is background sound, which is often at an NC-30 or greater in occupied spaces.

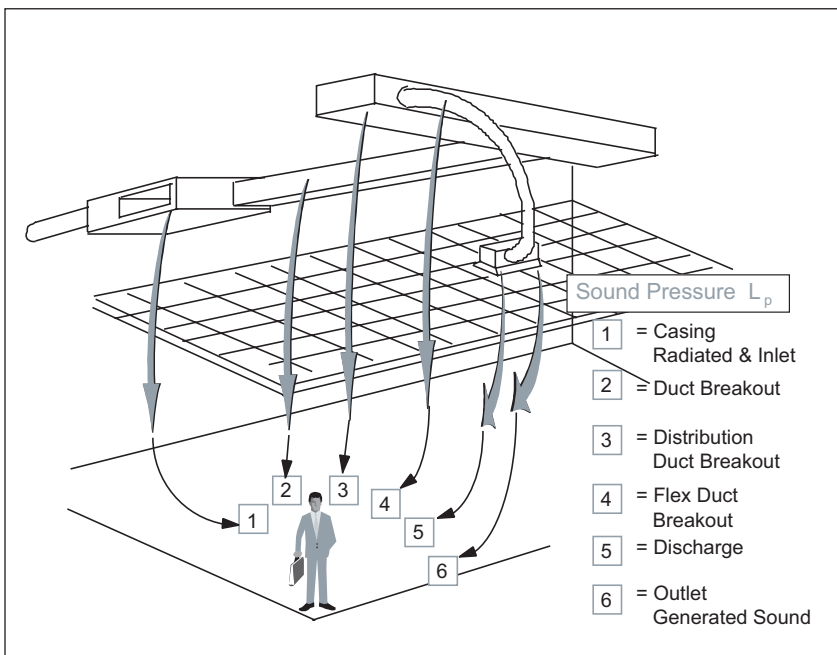

Figure 132. Fan Powered Terminal or Induction Terminal - Summary Calculation, Sound Sources and Paths



Redefine your comfort zone.™ | www.titus-hvac.com

All the sound paths must be combined to predict the room sound level.

When combining path elements, the math is done using log addition, not algebraically. Logarithmic (log) addition requires taking the antilog of the dB in each band, adding them together, then taking the log of the answer. While this sounds complicated, (Figure 133) here shows an easier way of estimating the result.

More importantly, most people cannot differentiate between two sources which differ by less than 3 dB. If the background sound is an NC-35, and the device in question is predicted at an NC-35, it is likely that the space will be at an NC-38 (although this is dependent on which octave bands are critical), but most people cannot hear the difference.

In a similar manner, sound from VAV boxes and diffusers combine to create the room sound pressure level. Since they peak in different bands, however, they often complement each other. In many cases, a Series Fan Terminal will be predicted to have an NC-30 in a space, but when combined with an NC-40 diffuser, will result in a room sound pressure level of NC-40, which is optimum for providing speech privacy in open plan spaces.

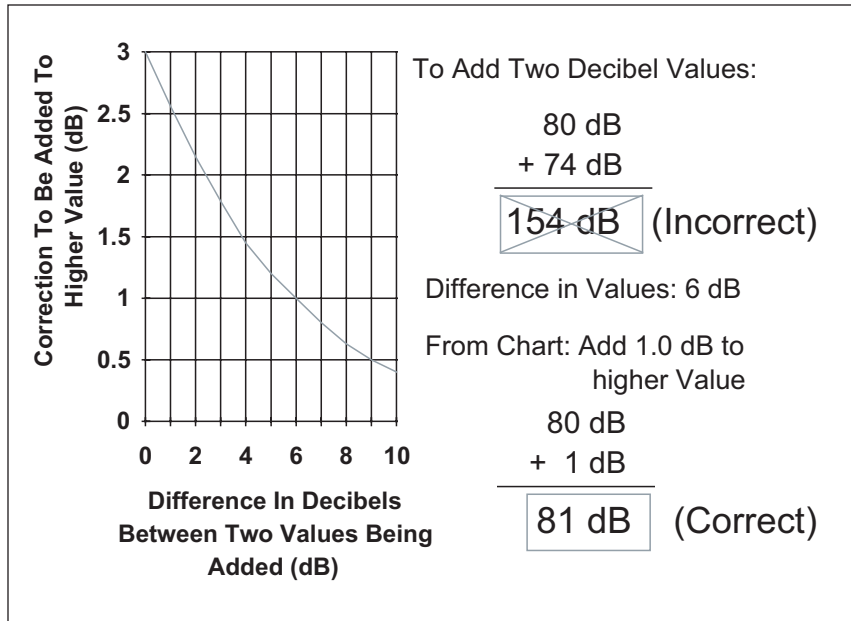

Figure 133. Decibel Addition Example (Incoherent Sound)

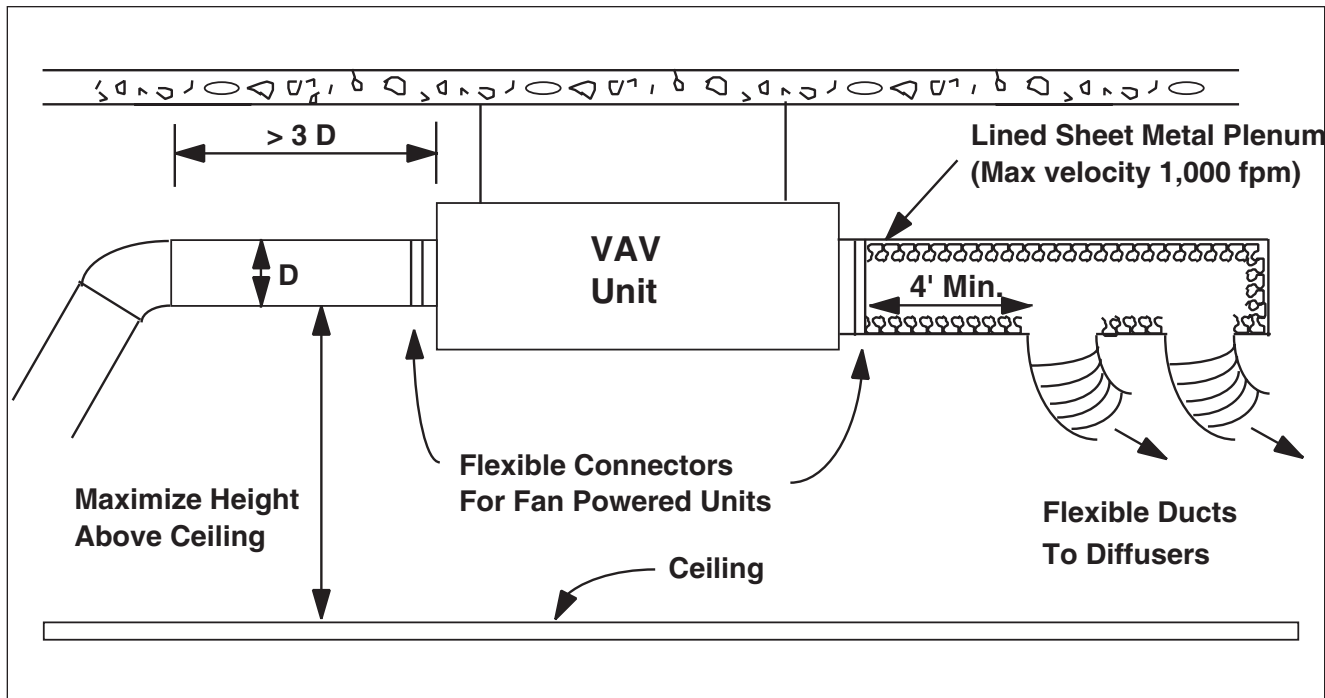

Figure 134. Quiet VAV and Fan Terminal Recommended Installation

## MAXIMUM SOUND POWER LEVELS FOR MANUFACTURERS' DATA

A proper specification for acoustical performance in a space will limit the maximum sound generation for a product. This should be based on the desired resultant sound in the space and accepted and clearly stated sound path attenuations/reductions. AHRI Standard 885 provides a consistent method for accomplishing this task.

### Example:

A designer wants to achieve RC 40N for an open office to achieve an acceptable level of speech privacy. The office has a 9 ft. ceiling and a volume of 3,000 ft.<sup>3</sup>. The terminal will be located over the occupied space with 5 ft. of lined duct on the discharge. The lined discharge duct is 14" x 14" outside with one inch of insulation (12" x 12" internal cross section). This duct branches into an unlined trunk duct with two runs of lined flex duct taking off to the outlet. The flex duct is 6 ft. long and 8" in diameter. The terminal will supply 600 cfm with each diffuser taking 300 cfm. The ceiling is made of 5/8-inch mineral fiber tile with a 35 lb. 1/4 ft.<sup>3</sup> density. The diffuser is selected to provide an NC 40(N) at design flow.

## DESIRED ROOM SOUND PRESSURE LEVELS

From AHRI Standard 885 the appropriate sound pressure levels for an RC 40 can be determined. Since a Neutral Spectrum is desired, the Rumble Roof and Hiss Roof can be added to the spectra and still result in a neutral designation. The resultant maximum room sound pressure spectra are:

Table 24. Maximum  $L_p$  for (RC 40N), dB

Octave Band	2	3	4	5	6	7
$L_p$ (RC 40N)	55	50	45	40	35	30
Rumble Roof	5	5	0	0	0	0
Hiss Roof	0	0	0	0	0	3
Max Room Sound Pressure	60	55	45	40	35	33

Engineers can minimize the sound contribution of air terminals to an occupied space through good design practice.

- Whenever possible, terminals should be located over areas less sensitive to noise. This includes corridors, copy rooms, storage rooms, etc. Quiet air terminals facilitate the location of terminals over unoccupied space as with these units larger zones are possible resulting in fewer terminals. This also reduces first cost and improves energy efficiency.
- The use of lined duct work or manufacturers' attenuators downstream of air terminals can help attenuate higher frequency discharge sound. Flexible duct (used with moderation) is also an excellent attenuation element.
- Sound will be reduced when appropriate fan speed controllers are used to reduce fan rpm rather than using mechanical devices to restrict airflow. This form of motor control is often more energy efficient.
- The air terminal and the return air grille location should be separated as far as possible. Radiated sound can travel directly from the terminal through the return air grille without the benefit of ceiling attenuation.
- Designing systems to operate at low supply air static pressure will reduce the generated sound level. This will also provide more energy efficient operation and allow the central fan to be downsized.
- Sharp edges and transitions in the duct design should be minimized to reduce turbulent airflow and its resulting sound contribution.

Figure 135. Sound Design Guidelines

## RADIATED SOUND POWER LEVEL SPECIFICATIONS

The ceiling/space effect may be determined from **Table 16, page B80**.

Octave Band Mineral Fiber	2	3	4	5	6	7
Tile 5/8" 35#/Ft <sup>3</sup>	16	18	20	26	31	36

The maximum acceptable radiated sound power levels are determined by adding all the factors, including the environmental factor. For example, in the 2nd band:

$$L_w \text{ RAD 2} = 55 (L_p) + 16 (C/S) + 2 (Env) = 73$$

(Octave band 2.  $L_w$  in bands 3-7 is calculated in a similar manner.)

For all bands, the following table results in a maximum allowed sound power, per AHRI Standard 880, to achieve an RC 40N:

Table 25. Allowed Sound Power Maximums (AHRI Standard 880)

Octave Band	2	3	4	5	6	7
$L_p$ (RC 40N)	60	55	45	40	35	33
C/S (Table 16)	16	18	20	26	31	36
Env Effect (Table 15)	2	1	0	0	0	0
$L_w$	78	74	65	66	66	69

For this specification to be compared evenly against all manufacturers, the environmental adjustment factor for manufacturers using a free field calibration Reference Sound Source (RSS), as required in AHRI Standard 880, has been subtracted from the appropriate manufacturer's data or added to the maximum acceptable sound power levels. If data is tested in another method, the appropriateness of the environmental factor must be understood and properly applied.

## DISCHARGE SOUND POWER LEVEL SPECIFICATIONS

The room absorption is determined by the space effect table. With a 10 ft. ceiling and the terminal located a few feet away from the receiver and a room volume of 3,000 ft.<sup>3</sup>. The effect varies with the octave band. The space effect will be obtained from **Table 12, page B40**.

Octave Band	2	3	4	5	6	7
Space Effect	9	10	10	11	12	13

End reflection is based on **Table 17, page B45**, and an 8-inch duct connection.

Octave Band	2	3	4	5	6	7
End Reflection	10	5	2	1	0	0

Duct insertion for 5 ft. of 8-inch lined flex duct can be taken from **Table 20, page B81**.

Octave Band	2	3	4	5	6	7
Flex Insertion Loss	5	10	18	19	21	12

No insertion value will be gained from the unlined trunk duct.

Flow division based on a 50 percent split (300 cfm / 600 cfm) can be taken from **Table 21, page B46**.

Octave Band	2	3	4	5	6	7
Flow Division	3	3	3	3	3	3

The rectangular tee attenuation can be taken from **Table 23, page B46**.

Octave Band	2	3	4	5	6	7
Tee Attenuation	0	0	1	2	3	3

Duct insertion for the 5 ft. of rectangular discharge duct can be taken from the AHRI Standard 885, or from **Table 19, page B45** in this case.

Octave Band	2	3	4	5	6	7
Duct Ins. Loss	2	4	10	20	21	14

Octave Band	2	3	4	5	6	7
$L_p$ (RC 40N)	60	55	45	40	35	33
Env Effect (Table 15)	2	1	0	0	0	0
Space (Table 12)	9	10	10	11	12	13
End Ref (Table 17)	10	5	2	1	0	0
FLEX (Table 20)	5	10	18	19	21	12
Flow Div (Table 21)	3	3	3	3	3	3
Elbow & Tee (Table 23)	0	0	1	2	3	3
Rect Duct (Table 19)	2	4	10	20	21	14
$L_w$	91	88	89	96	95	78

As with radiated sound, the environmental adjustment factor for manufacturers using a free field calibration RSS, as required in AHRI Standard 880, has been subtracted from the appropriate manufacturer's data or added to the maximum acceptable sound power levels. If data is tested in another method, the appropriateness of the environmental factor must be understood and properly applied.

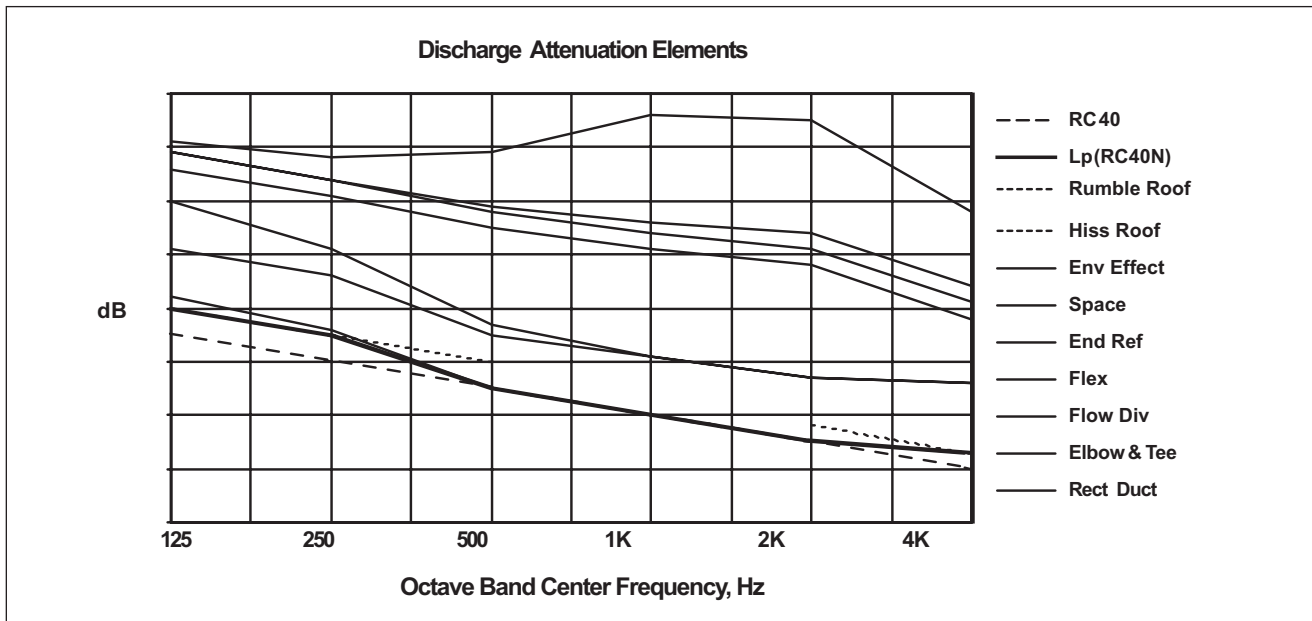

Figure 136. Fan Powered Terminal or Induction Terminal - Summary Calculation, Sound Sources and Paths

It can be seen that discharge sound is not likely to be a problem, especially in the mid-frequencies. If duct lining is eliminated, however, the maximum allowable power is reduced by the duct insertion loss data on the previous page. If flex duct is disallowed, the maximum sound power allowed is further decreased by flex insertion loss. This can result in the following requirement for the unit:

Octave Band	2	3	4	5	6	7
No Lining / Flex	83	74	61	56	53	52

In many cases, this is a borderline acceptable case for many unit sizes and flow rates, especially in smaller rooms with RC 35N requirements. Flexible duct can be included as a solution to discharge noise in these cases.

### DIFFUSER SPECIFICATIONS

Diffusers are commonly specified and reported in NC, rather than RC. In most cases, there is no difference between NC and RC for diffusers as they usually peak in the 500-2,000 Hz region, and the resultant numerical specification is the same for both NC and RC. Diffuser NC ratings commonly subtract 10 dB from measured sound power levels in all bands to account for room attenuation. As described earlier, this will be a valid assumption for a number of combinations of room volume and distance to the source. While an ideal specification will be based on octave band sound levels, these are seldom available for diffusers, and so the NC rating must be used. For a close approximation of diffuser sound power when only NC is known, one can assume that the sound power for the diffuser in the 5th octave band (1,000 Hz) is equal to the reported NC plus 10 dB, the 4th band (500 Hz) is 3 greater than this, and the 6th band (2000 Hz) is 5 less. This will be suitable for most applications.

The room sound pressure level requirements should be based on the resultant desired acoustical environment. As the only attenuation element for diffusers is the room effect, this should be the primary attenuation path.

Diffusers, moreover, have typically been tested in the same facilities as VAV terminals, with the same reference sound source, and therefore the AHRI Standard 885 Environmental Effect must be included as well. The following is a proposed procedure for determining the Diffuser NC requirement based on an RC analysis:

Steps:

1. Determine the desired RC level for the space. This is the sound pressure level requirement in the 5th band.
2. Determine the room effect in the 5th (1,000 Hz) band, based on room volume and distance to the diffuser from the observer. Add this to the RC number.
3. Subtract 10 dB from the result in Step 2. This is the required diffuser NC.

**Example:** The open office from the previous example is used here. The room is large and speech privacy is desired, requiring an RC 40N specification.

**Steps:**

1. From AHRI Standard 885 the appropriate sound pressure levels for an RC 40 can be determined. In the 5th band the RC is = to the sound pressure level requirement, 40 dB.
2. The room absorption is determined from the space effect equation. With a 10 ft. ceiling and the terminal located a few feet away from the receiver, the distance variable will equal 10 ft. The volume of the room is 3,000 ft.<sup>3</sup>. The frequency varies with the octave band. The space effect in the 5th band will be obtained from **Table 12, page B76**, and is = 11 dB. 40 + 11 = 51 dB.
3. Subtract 10dB = the diffuser's NC requirement, or NC 41.

### DETERMINING COMPLIANCE TO A SPECIFICATION

When determining if a unit will meet a specification, it may be necessary to conduct a total room sound evaluation with multiple sound sources and multiple paths. These are added using logarithmic addition to determine total sound level. Once all path elements are identified, the noncritical paths can be determined using **(Figure 133)**, page B47. Paths which are 10 dB or more below the loudest, in any given band, can usually be ignored.

VAV terminals, if evaluated by themselves, often result in an "R" classification because of the high mid-frequency absorption provided by lined and flexible duct. The diffuser, however, can overcome this apparent "Rumble" spectra by filling in the resultant sound with its high frequency sound generation. This results in an "N" rating, as required. Using the estimated sound power procedure from the Diffuser Specification section above, the diffuser's contribution can be added (using log addition) to the VAV boxes sound pressure level, and a resultant sound pressure level classification developed.

**Example:** A project engineer desires a space sound pressure level of RC 35(N) for a private office. He has selected a Titus TQS Fan Terminal, size 5-12, at 1500 cfm, with a design inlet pressure of 1 in. static pressure. From the sound tables for the product, the sound power levels for this unit and the reduction factors as in the previous example are shown above:

Octave Band	2	3	4	5	6	7
Unit Pwl	71	64	59	57	50	45
C / S (Table 16)	16	18	20	26	31	36
Env Effect (Table 15)	2	1	0	0	0	0
Estimated Room Spl	53	45	39	31	19	9

As the estimated room sound pressure level exceeds the rumble roof in the 2nd band, this unit must be classified RC 29 (R). If an RC 35 (N) diffuser is also supplied, however, the sound from it must be added to the terminals to get the room total sound level. Using the procedure described under "Diffuser Specification", we can estimate the sound power level of an NC-35 diffuser:

Octave Band	2	3	4	5	6	7
Diffuser Pwl			48	45	40	
Space Effect (Table 12)	9	10	10	11	12	13
Env Effect (Table 15)	2	1	0	0	0	0
Estimated Diffuser Spl			38	34	28	

When these are added, the resulting spectra is:

Octave Band	2	3	4	5	6	7
Diffuser Pwl			38	34	28	
Terminal Spl	53	45	39	31	19	9
Log Sum	53	45	41	36	29	9

The RC = (41 + 36 + 29) / 3 = 35. The rumble roof for this spectra is therefore

Octave Band	2	3	4
Rumble Roof	55	50	40

Therefore the sound pressure level in the space is an RC 35 (N). This works because diffusers and VAV terminals seldom peak in the same frequencies, with diffusers being critical in the speech bands (500-2,000 Hz) and boxes producing the most sound in the 125-250 Hz region. When these two sounds combine in the space, they often complement each other, producing a full spectrum of sound and resulting in an "N" rating.

### IMPORTANT END REFLECTION CHANGES IN AHRI 880

As of January 1, 2012, AHRI 880 requires that discharge sound power data for terminal units from all manufacturers be adjusted to include end reflection. End reflection is sound that is reflected back to the source from the discharge duct termination in the sound chamber. Since this sound cannot be measured, it can only be calculated. According to ASHRAE research, the end reflection loss can be calculated based on the dimensions of the discharge duct. This calculated end reflection loss (not to exceed 14 dB) must then be added to 1/3 octave band sound data in order to make the correction. This change was made to correct the fact that room noise criteria (NC) ratings based on AHRI 885 include an end reflection deduction, when in fact the end reflection losses were never included. The end result is that catalog discharge sound levels (both sound power and NC) on all ducted terminal units increased while the products have remained unchanged. The changes are most noticeable on units with smaller discharge ducts.