

Square and Rectangular Ceiling Diffusers

Aluminum • Louvered Face • Induction Vanes

Model: TDVAA-NT • Narrow Tee • Square, Rectangular or Round Neck

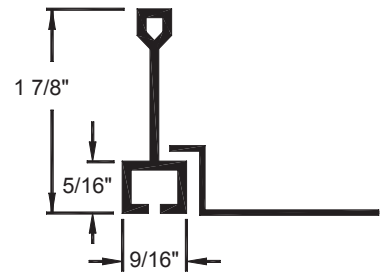
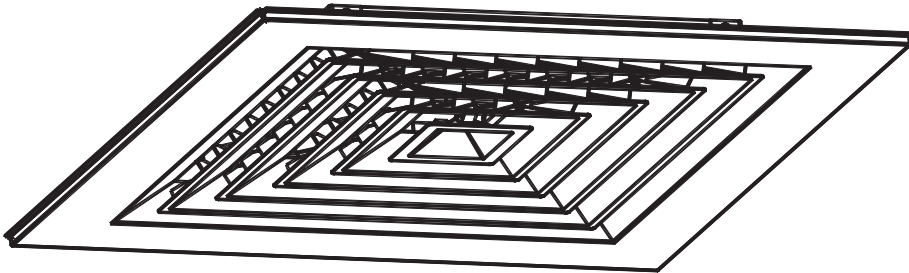

Narrow Tee Detail

Border Type NT (Narrow Tee) Square or Rectangular Neck

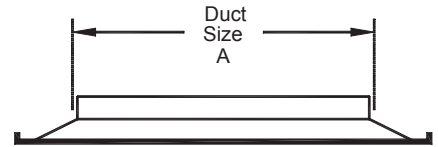
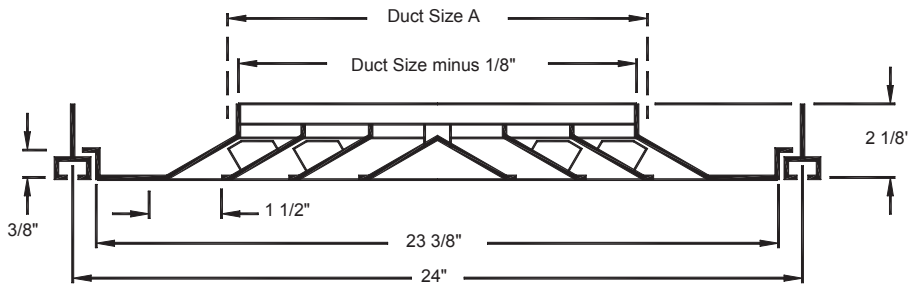

| Available Module Size | Minimum Duct Size | Maximum Duct Size |
|-----------------------|-------------------|-------------------|
| 24 x 24 | 6 x 6 | 18 x 18 |





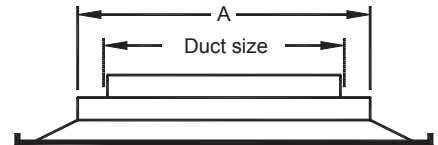
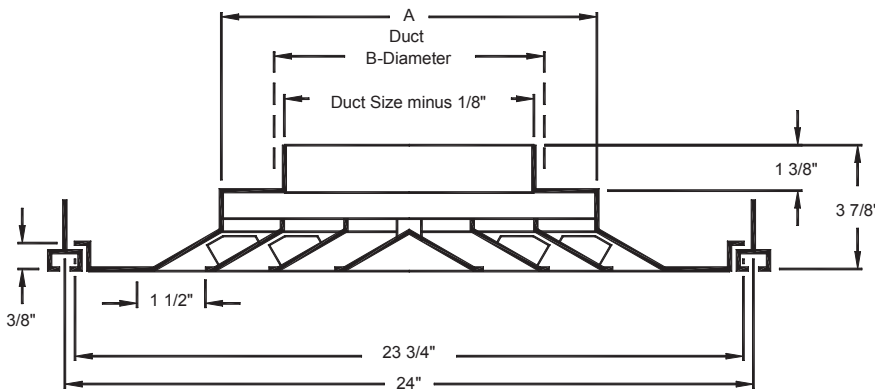









Note: Duct sizes are available in 3" increments only.

Border Type NT (Narrow Tee) with Steel Round Neck

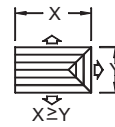
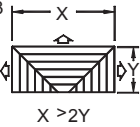
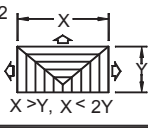
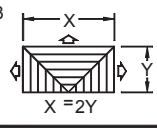

| Available Module Size | Minimum A | Available Round Duct Size B |
|-----------------------|-----------|-----------------------------|
| 24 x 24 | 6 x 6 | 6 |
| | 9 x 9 | 6, 8 |
| | 12 x 12 | 6, 8, 10, 12 |
| | 15 x 15 | 6, 8, 10, 12, 14 |
| | 18 x 18 | 6, 8, 10, 12, 14, 16 |

Optional Patterns selection

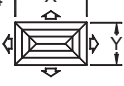
| | | | |
|---|--|--|--|
|  1 Way | <input type="checkbox"/> S1 Square  | <input type="checkbox"/> A1  | <input type="checkbox"/> B1  |
|  2 Way | <input type="checkbox"/> A2  | <input type="checkbox"/> S2 Square  | <input type="checkbox"/> B2  |
|  2 Way Corner | <input type="checkbox"/> E2  | <input type="checkbox"/> F2  | <input type="checkbox"/> G2 Square  |
|  3 Way | <input type="checkbox"/> A3  | <input type="checkbox"/> E3  | For A3, $X > Y$ For A3-2, $X > Y, X < 2Y$ For B3, $X = 2Y$ For E3, $X > 2Y$ * Dimensions X and Y shown here are the proportions of available rectangular duct sizes. Duct sizes are available in 3" increments. Dimension X is always the longer dimension for each core option. |
| | <input type="checkbox"/> A3-2  | <input type="checkbox"/> B3  | |
| | | | |
|  4 Way | <input type="checkbox"/> A4 Square  | <input type="checkbox"/> B4  | |

Removing Center Core

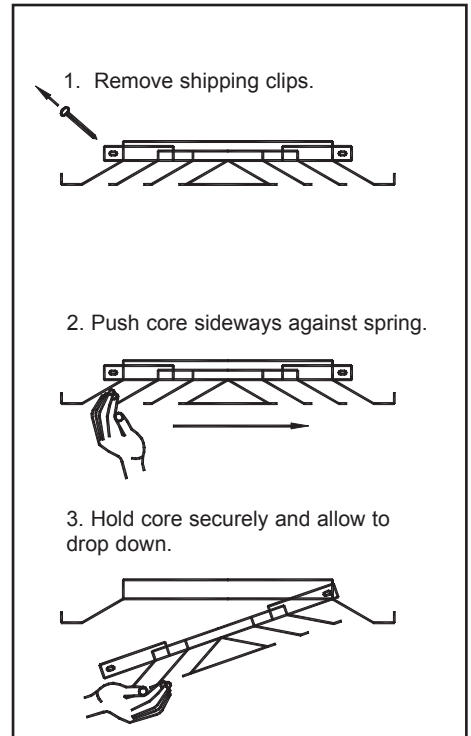

Optional Accessories if provided

| Accessories | Nominal Round Duct Sizes | | | | | |
|---------------------------------|--------------------------|---|----|----|----|-----|
| | 6 | 8 | 10 | 12 | 14 | 16 |
| <input type="checkbox"/> AG-100 | • | • | • | • | • | N/A |
| <input type="checkbox"/> D-100 | • | • | • | • | • | N/A |
| <input type="checkbox"/> AG-85 | • | • | • | • | • | • |
| <input type="checkbox"/> AG-65 | • | • | • | • | • | • |
| <input type="checkbox"/> EG | • | • | • | • | • | • |
| <input type="checkbox"/> EQT | • | • | • | • | • | • |

| Accessories | Nominal Rectangular Duct Sizes |
|-----------------|---|
| AG-95 Type 1 | Available in Sizes 6 x 6 through 18 x 18 |
| AG-35B | |
| EG-L/EG-S | |
| AG-65-L/AG-65-S | |
| EQT | |

• Available Sizes

Standard Finish: #26 White

General Description

- TDVAA-NT is designed to integrate into 24 x 24" Narrow Tee regressed ceiling systems.
- TITUS Model TDVAA-NT is a high capacity ceiling diffuser. Because it maintains an unbroken horizontal flow pattern from maximum cfm down to minimum, it is an excellent choice for variable air volume applications.
- Core is removable from the face of the diffuser.
- Model TDVAA-NT is extremely flexible, with cores available for 1, 2, 3 or 4-way horizontal flow patterns.
- Material is aluminum.
- The TITUS TDVAA-NT has a louvered face with integrated induction vanes for exceptional air mixing.
- Slot operator on optional, neck-mounted Model AG-95 damper allows easy volume adjustment by removing the diffuser core. (Rectangular necks only).



Note: This submittal is meant to demonstrate general dimensions of this product. The drawings on this submittal are not meant to detail every aspect of the product with exactness. Drawings are not to scale. TITUS reserves the right to make changes without written notice.
605 Shiloh Road • Plano, Texas 75074 • 972-212-4800

D-44.5-S