

## T<sub>3</sub> Series VAV Diffusers

Thermal Diffuser • Steel • Square Panel • Horizontal Pattern

Model: T<sub>3</sub>SQ

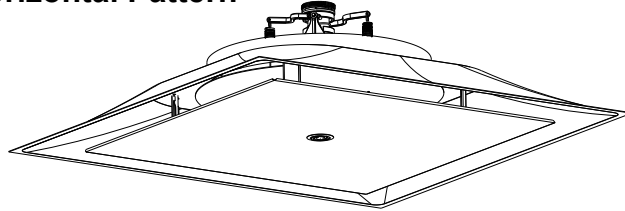

### Model Configurations

T<sub>3</sub>SQ-4 – Heating / Cooling

Border Type 3 (Lay-In) Full Face

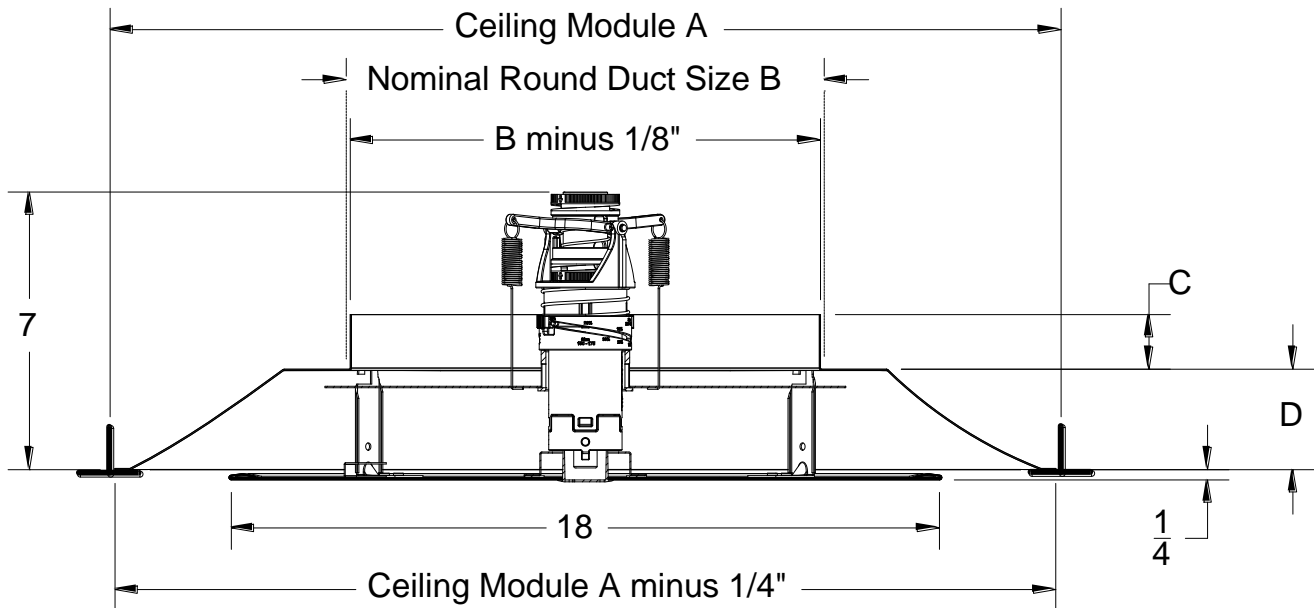

Dimensions are in inches.

Ceiling Module A	Nominal Round Duct Sizes B	C	D
24	6	1 1/8	3 5/8
	8	1 1/4	3 3/4
	10, 12	1 3/8	3 7/8

Ceiling Module	Face Size	Nominal Round Duct Size	Border Type
24 x 24	24 x 24	6, 8, 10, 12	2, 3, 4, 5, NT

### Other Available Border Types Check if provided.

Border Type 1 Rapid Mount Frame for Surface Mounting Applications.

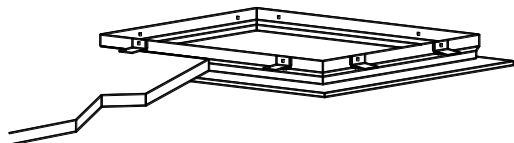

The T<sub>3</sub>SQ series of diffusers are not available with standard border type 1. For surface mounting applications, the TRM optional Rapid Mount frame can be used. Using border option TRM, the T<sub>3</sub>SQ series diffusers are shipped with border type 3 (lay-in). The TRM frame is shipped separate for field installation. Once the TRM is installed, the T<sub>3</sub>SQ diffuser simply lays into the frame. This option allows access into the ceiling after installation.

Border Type NT (Narrow Tee)

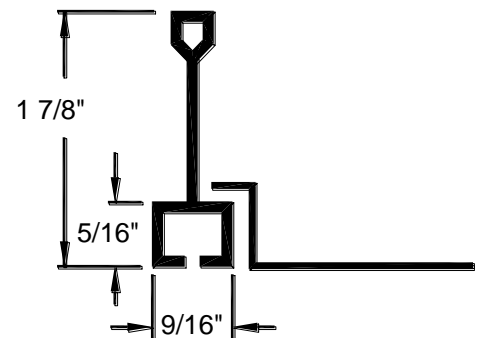

Other Available Border Types – cont.

Check  if provided.

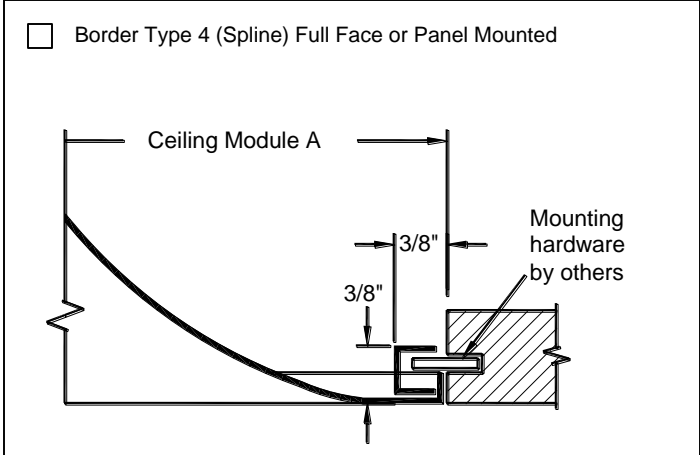
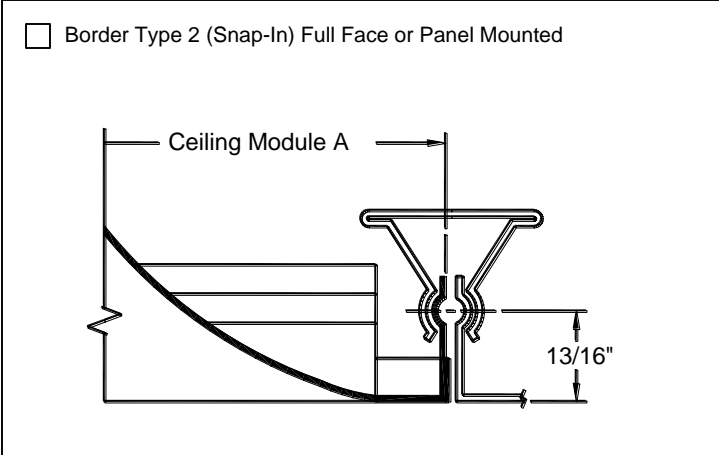

Standard Finish: #26 White

Easy three step hook installation for the face plaque

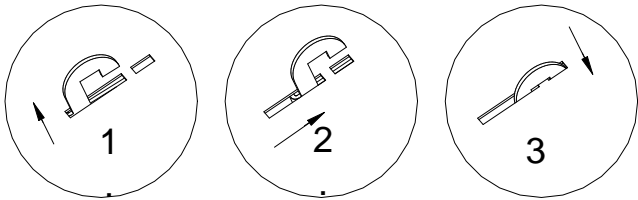

Backpan

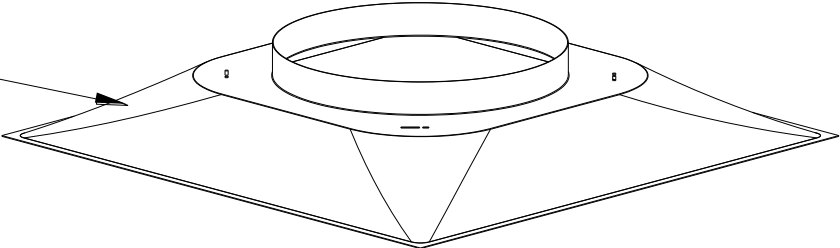

Thermal Actuator

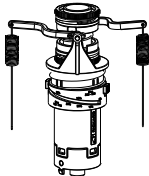

Control Disc

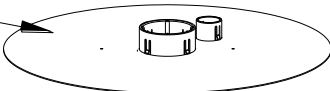

Venturi Tube



Induction Channel

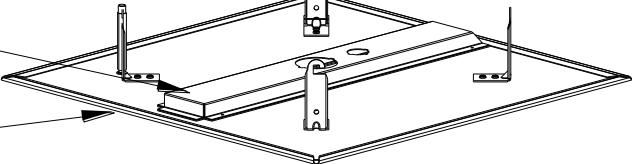

Face Plaque

Induction Cap



Check  if provided.

## Pressure Relief Ring

- Relieves pressure by bypassing excess supply air to the ceiling plenum as the control disc closes
- Attaches to diffuser inlet
- Reduces diffuser inlet size by 2".
- Performance will be based on relief ring size
- Only available on size 10 and size 12 units

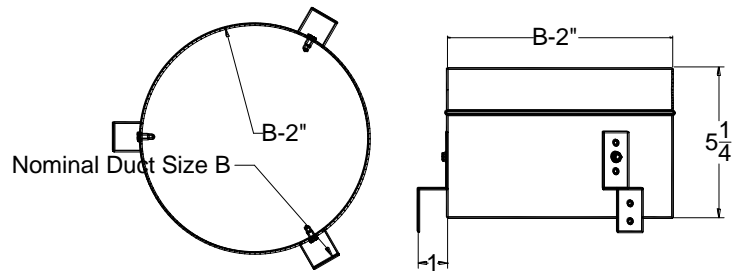

## Adjustment Rings

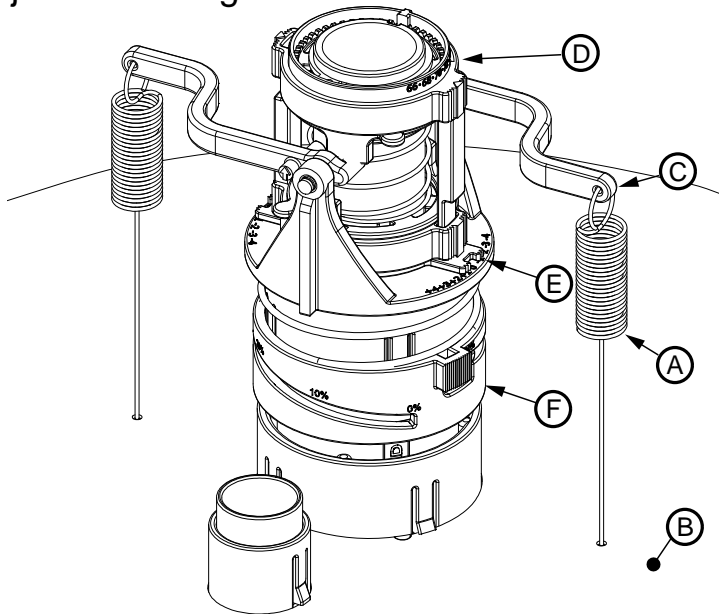

Control disc springs (A) must be disconnected from control disc (B) to ensure that the diffuser is in the fully open position for commissioning purposes.

After commissioning, ensure that each control disc spring (A) is attached to both the control disc (B) and the lever arm (C).

To adjust cooling temperature setpoint, turn adjustment ring (D) so that the center vertical bar lines up with the desired temperature.

To offset the temperature in heating mode, adjust the offset tab (E) in either direction.

Minimum airflow is set by using the grey ring (F). This is expressed as a percentage of maximum airflow. Full shut off is achieved by turning the grey ring (F) fully clockwise.

## General Description

- The T<sub>3</sub>SQ-4 is a thermal variable volume diffuser. The diffuser maintains space temperature by varying the volume of air delivered to the space. The amount of air delivered will depend on the supply air temperature (SAT), the room temperature setpoint, and the room temperature.
- The T<sub>3</sub>SQ-4 is available in heating and cooling configurations.
- As the volume of air is decreased by the control disc, the velocity of air is increased, thereby maintaining the longest throw and best entrainment. This insures superior air distribution at all damper positions.
- The curvature of the backpan works with the formed edges of the face panel to deliver a tight horizontal air pattern, without excessive noise or pressure drop over the full range of operation.
- The T<sub>3</sub>SQ-4 uses an induction plug to accurately measure the room temperature. This eliminates the need for a wall mounted thermostat or sensor and provides the most accurate way of measuring the room air temperature.
- The position of the control disc is varied by means of a wax filled thermal element which responds to changes in sensed temperature. The wax contained in the thermal element melts at the formulated temperatures to expand or contract the actuator assembly, modulating the control disc.
- When the wax cools down the actuator assembly retracts under the action of a return spring, causing the control disc to move in the opposite direction to counter the change in sensed temperature.
- Adjustment of the room temperature setpoint is achieved by rotating the adjustment ring. The adjustment ring has calibrated markings and the setpoint may be adjusted to suit individual requirements.
- Adjustment of minimum airflow is achieved by rotating the minimum airflow adjustment ring.
- The T<sub>3</sub>SQ diffuser is designed to satisfy architectural, as well as, engineering criteria. The strong, clean, unobtrusive lines harmonize with the ceiling, without sacrificing performance. The standard finish is #26 White.
- The face panel and backpan are constructed from 18 gauge steel. The formed outer edge also assures a straight and level surface.

This submittal is meant to demonstrate general dimensions of this product. The drawings are not meant to detail every aspect of the product. Drawings are not to scale. Titus

reserves the right to make changes without written notice.

All rights reserved. No part of this work may be reproduced or transmitted in any form or by any means, electronic or mechanical, including photocopying and recording, or by any information storage retrieval system without permission in writing from Air Distribution Technologies, Inc.