

TAF-HC

Series Access Floor Diffuser

Diffuser Heating / Cooling Plenum, Dual Inlet with Damper

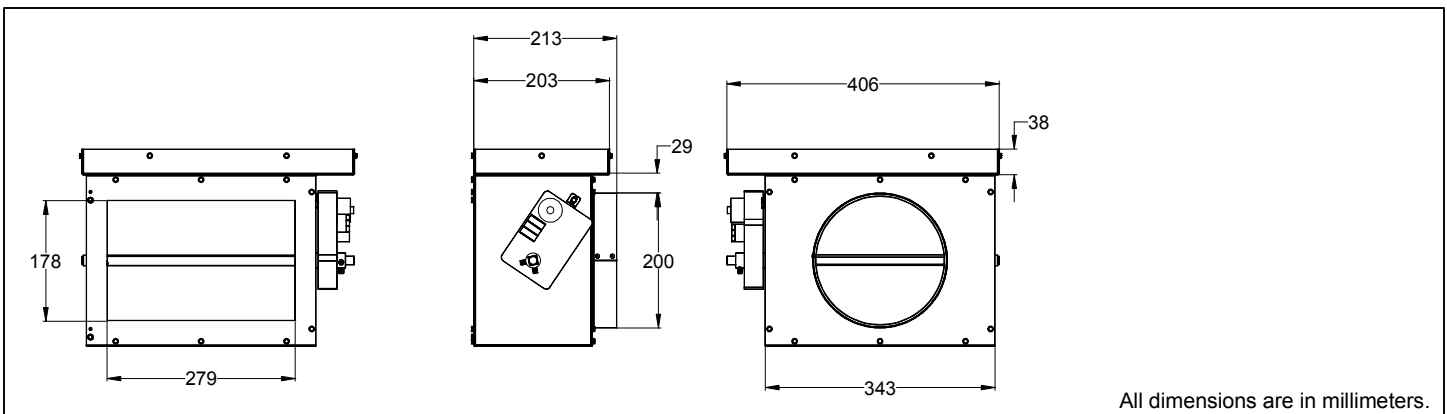
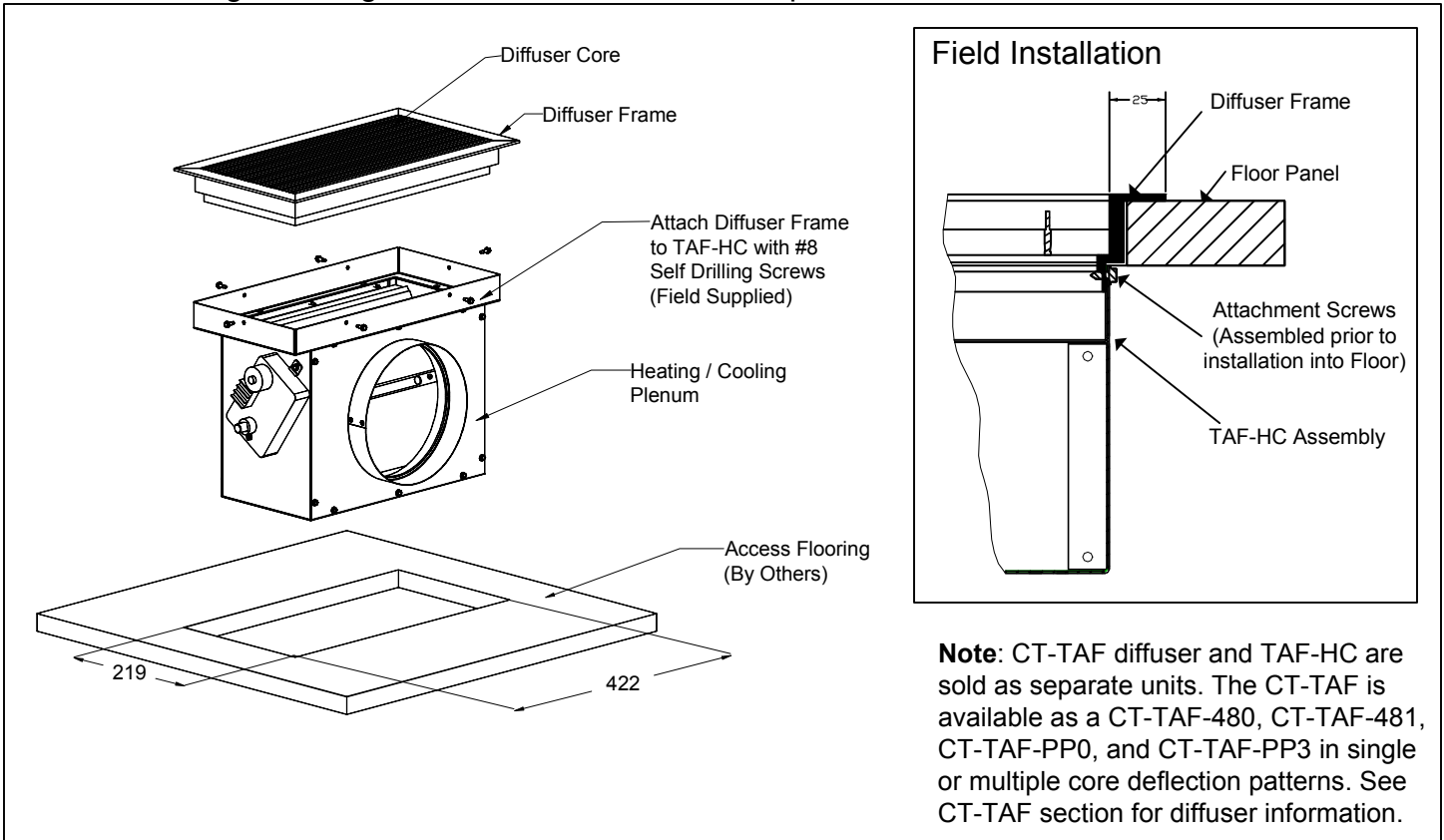

Accessories (Optional)

Check if provided.

24V Actuator (Proportioning)

Thermostat (Proportioning)

General Description

- The TITUS model TAF-HC ducted plenum is designed for application in access floor air distribution systems for use as a ducted supply or return.
- Heavy gauge diffuser designed for floor applications.
- The TAF-HC plenum is constructed of a heavy gauge steel housing.
- Installs into access flooring from top surface. Removal of flooring is not required.

This submittal is meant to demonstrate general dimensions of this product. The drawings are not meant to detail every aspect of the product. Drawings are not to scale. Titus

reserves the right to make changes without written notice.