

TVSM TWIN PACK PRIMARY & SECONDARY UNIT DIMENSIONS

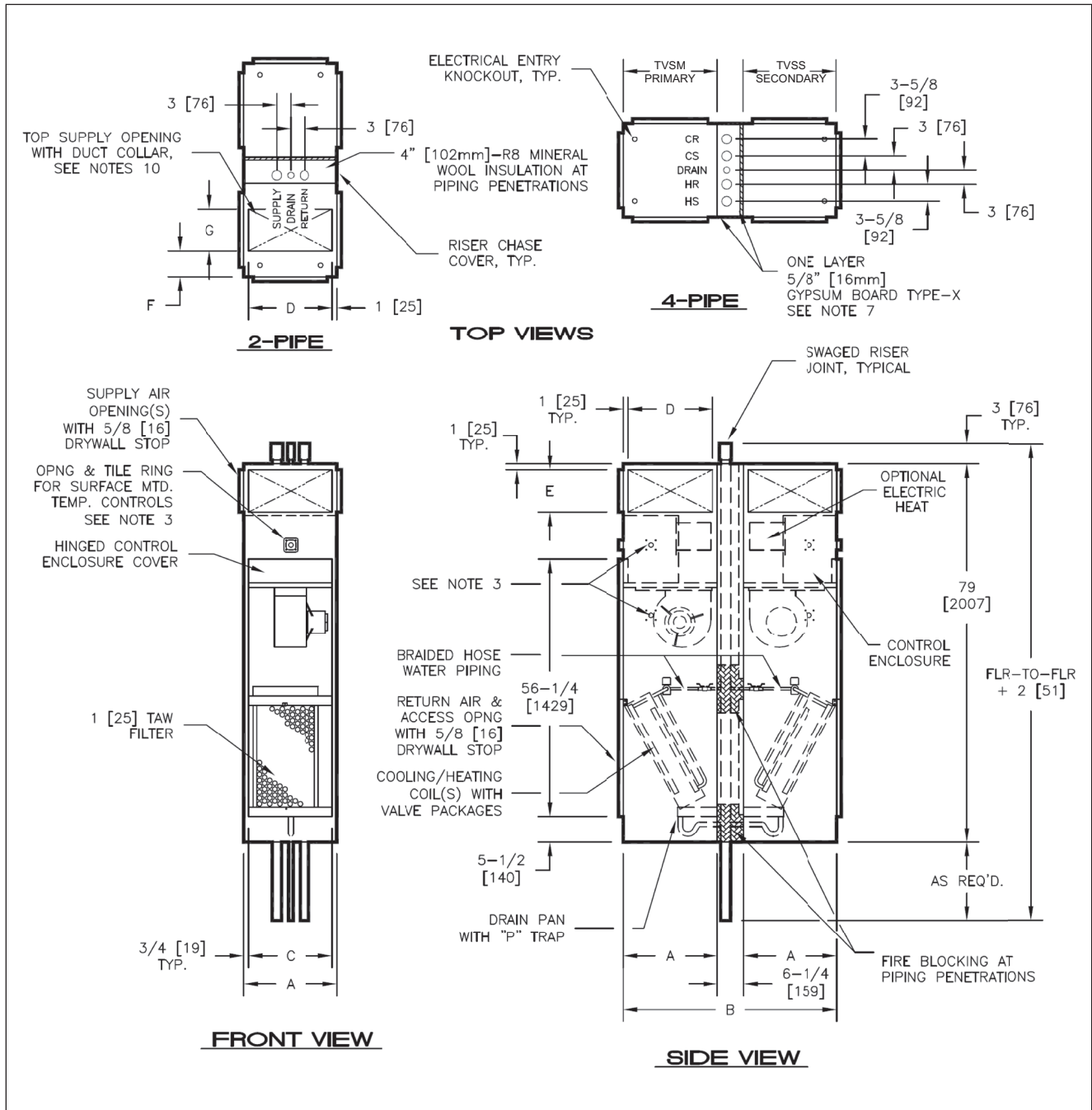

TVSM TWIN PACK PRIMARY & SECONDARY UNIT DIMENSIONS

Dimensions						Supply Air		
						Single / Double	Top	
TVSM (Primary)	TVSS (Secondary)	A	B	C	D	E	F	G
03 or 04	03 or 04	18 [457]	42 ¼ [1073]	16 ½ [419]	16 [406]	8 [203]	6 [152]	8 [203]
03 or 04	06 or 08	20 [508]	46 ¼ [1175]	18 ½ [470]	18 [457]	12 [305]	6 [152]	12 [305]
03 or 04	10 or 12	24 [610]	54 ¼ [1378]	22 ½ [572]	22 [559]	14 [356]	8 [203]	14 [356]
06 or 08	03 or 04	20 [508]	46 ¼ [1175]	18 ½ [470]	18 [457]	12 [305]	6 [152]	12 [305]
06 or 08	06 or 08							
06 or 08	10 or 12	24 [610]	54 ¼ [1378]	22 ½ [572]	22 [559]	14 [356]	8 [203]	14 [356]
10 or 12	03 or 04	24 [610]	54 ¼ [1378]	22 ½ [572]	22 [559]	14 [356]	8 [203]	14 [356]
10 or 12	06 or 08							
10 or 12	10 or 12							

Notes:

1. All dimensions are inches [mm]. Metric values are soft conversion.
2. All dimensions are ± ¼ [6mm]
3. Thermostat mounting – Tile ring is installed on front of unit as shown and may be moved to left or right of unit as shown and may be moved to left or right side of unit in field
4. Wiring from electrical entry point to control enclosure is furnished and installed by others in field
5. Risers available from ¾" [19mm] to 2-½" [64mm] diameter with ½" [13mm] or ¾" [19mm] thick insulation
6. Riser length is 120" [2921mm] max, 100" [2540mm] min
7. NON-FIRE RATED unit shown with type-X gypsum board at back of Secondary unit. FIRE RATED units have type-X gypsum board at back of both Secondary and Primary units. FIRE RATED unit design has been tested in accordance with UL1479 - Fire Test Of Through Penetration Fire Stops, and is approved to bear the ETL listing mark for Through Penetration Fire Stop Assemblies.
8. For further fire rating information refer to the Installation Instructions
9. Refer to arrangement drawings for available Twin Pack Primary and Secondary unit configurations

Twin Pack Primary and Secondary Models TVSM/TVSS ship complete with risers enclosed in a wall plenum with one layer of 5/8" gypsum for sound attenuation. As an option, Twin Pack Primary and Secondary unit may be ordered with two layers of 5/8" gypsum and fire blocking material for a one hour fire rating per UL 1479.