

# Square and Rectangular Ceiling Diffusers Aluminum • Louvered Face • High Capacity

Model: TDC-AA • Square, Rectangular or Round Neck

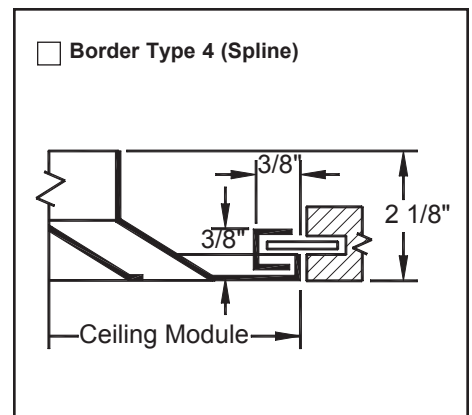
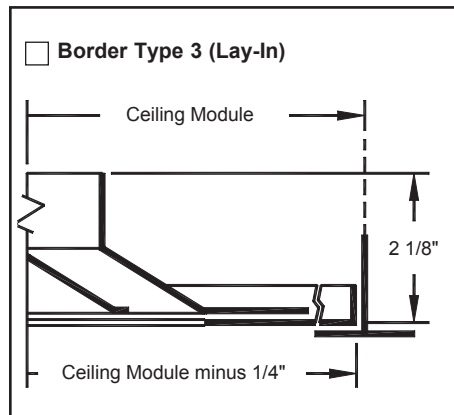
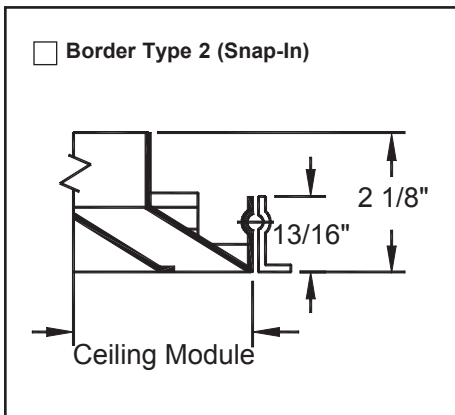
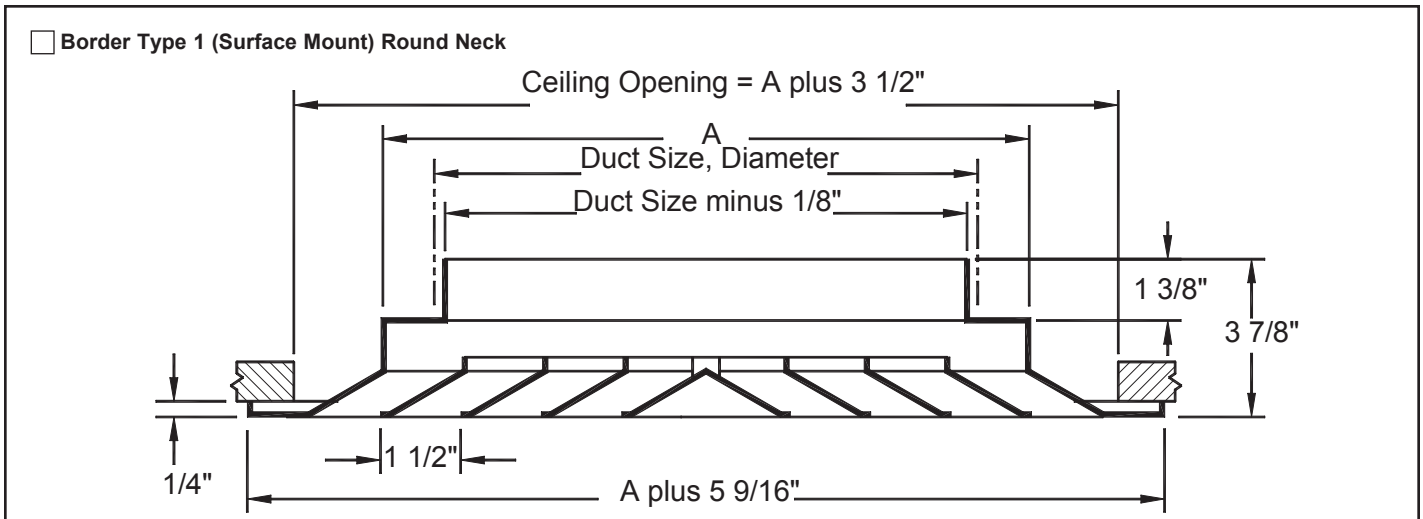
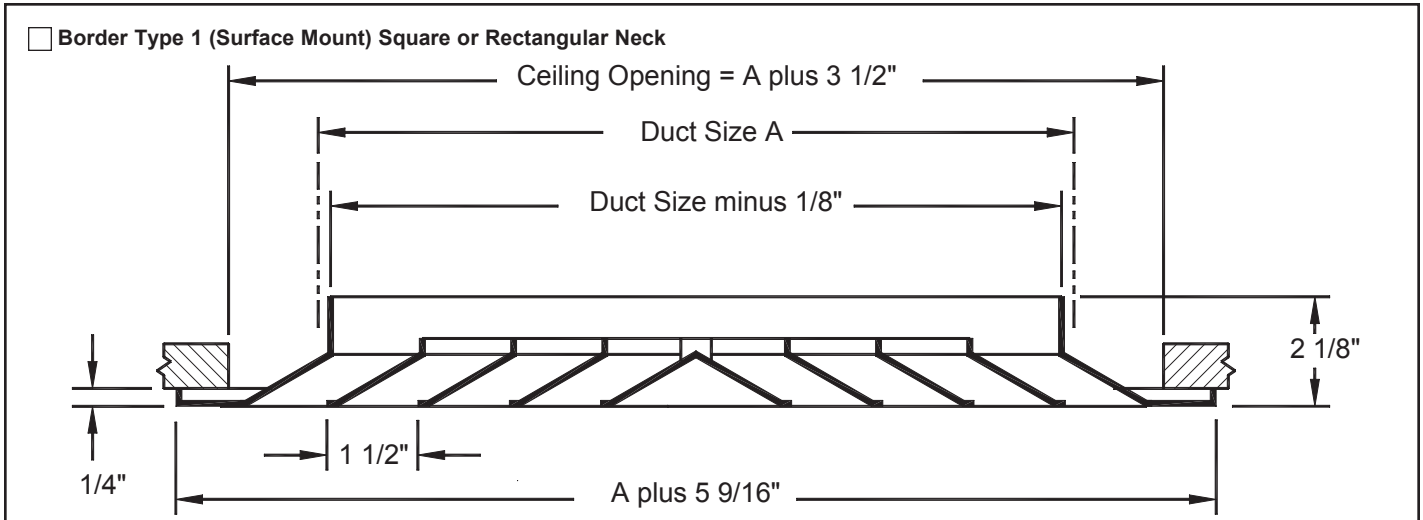

For Dimensions "A" see table on next page.

Dimensions are in inches.

D-40.0-S

(Please see reverse side).

## Border Types, Dimensions (Continued)

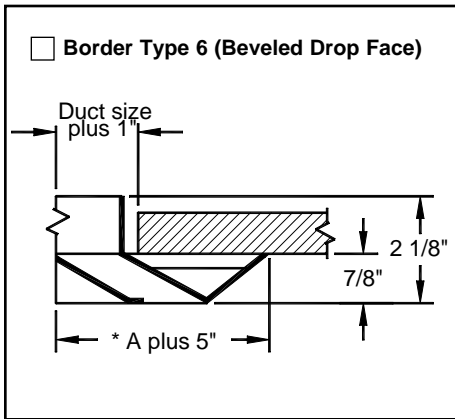

\* **Note:** Dimension A refers to either square/rectangular or round neck diffusers. See drawings below.

## Available Duct Sizes, Square and Rectangular Necks

Border Type 1, 6	
Minimum Duct Size A	Maximum Duct Size A
6 x 6	48 x 48

Border Type 2, 3, 4		
Available Module Size	Minimum Duct Size A	Maximum Duct Size A
12 x 12	6 x 6	9 x 9
24 x 24	6 x 6	21 x 21
48 x 24	12 x 12	42 x 21

\***Note:** Duct sizes are available in 3" increments only.

## Available Duct Sizes, Round Necks

Border Type 1, 6	
Dimension A	Available Duct Size
6 x 6	6
9 x 9	6, 8
12 x 12	8, 10, 12
15 x 15	6, 8, 10, 12, 14
18 x 18	6, 8, 10, 12, 14, 16

Border Type 2, 3, 4		
Available Module Size	Minimum A	Available Rnd. Duct Size
12 x 12	6 x 6	6
	9 x 9	6, 8
24 x 24	6 x 6	6
	9 x 9	6, 8
	12 x 12	8, 10, 12
	15 x 15	12, 14
	18 x 18	6, 8, 10, 12, 14, 16

\***Note:** Round duct sizes are available only in sizes shown.

All dimensions are in inches.

# Accessories (Optional) for Round Neck

Check  if provided

Model AG-100 Radial Sliding Blade Damper \*

Model EG Equalizing Grid

AG-100 Mounts Above Neck

1 Model AG-100 damper is available in duct sizes 6 thru 14 inches only

Model D-100 Radial Sliding Blade Damper \*

Model EG Equalizing Grid

D-100 Mounts on Neck

2 Model D-100 damper is available in duct sizes 6 thru 14 inches only.

Model D-75 Opposed Blade Damper \*

Model EG Equalizing Grid

D-75 Mounts on Neck

3 Model D-75 damper is available in duct sizes 6 thru 12 inches only

Model AG-85 Butterfly Damper \*

Model EG Equalizing Grid

AG-85 Mounts Above Neck

4

Model AG-65 Combination Damper and Equalizing Grid \*

AG-65 Mounts Above Neck

5

Model AG-75 Opposed Blade Damper \*

Model EG Equalizing Grid

AG-75 Mounts Above Neck

Size	B
6-12	1 1/2
14-16	2 1/8

6

Dimension "A" in Inches, for Dampers Shown as Above

Accessories	Nominal Round Duct Sizes					
	6	8	10	12	14	16
1 AG-100	—	—	—	—	—	N/A
2 D-100	—	—	—	—	—	N/A
3 D-75	2 3/8	3 1/4	4 1/8	4 7/8	N/A	N/A
4 AG-85	2 1/2	3 1/2	4 1/2	5 1/2	6 1/2	7 1/2
5 AG-65	3 3/8	4 1/2	5 1/2	7 1/8	8 5/8	9 7/8
6 AG-75	4 1/4	5 1/8	6	6 7/8	2 3/4	3 1/2

**Notes 1 and 2 :**

Model AG-100 and D-100 dampers have radial blades that slide in a horizontal plane. For that reason, no opening clearance "A" is dimensioned.

**\*Damper operators** on all round neck dampers are screwdriver type. Remove diffuser core (See back page) for access.

# Accessories (Optional) for Rectangular Neck

Check  if provided

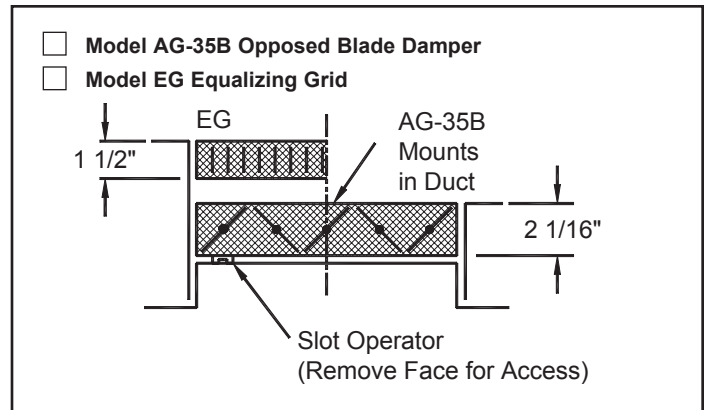
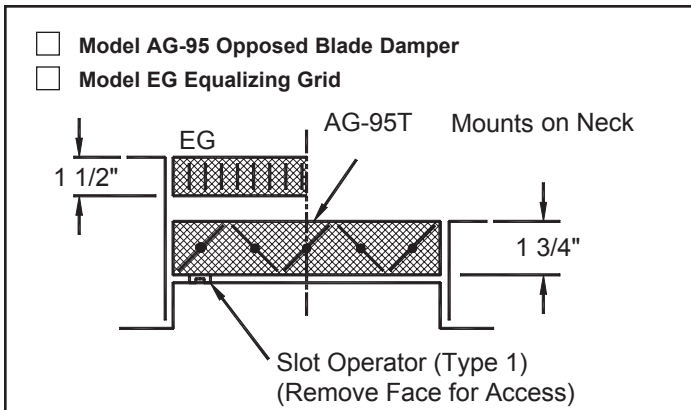

All dimensions are in inches.

## Other Accessories (Optional)

Standard Finish: #26 White

- Model TRV Throw Reducing Vanes
- Model SR Square-to-Round Transition

## Optional Patterns

Check  selection

1 Way	<input type="checkbox"/> S1 Square	<input type="checkbox"/> A1	<input type="checkbox"/> B1
2 Way	<input type="checkbox"/> A2	<input type="checkbox"/> S2 Square	<input type="checkbox"/> B2
2 Way Corner	<input type="checkbox"/> E2	<input type="checkbox"/> F2	<input type="checkbox"/> G2 Square
3 Way	<input type="checkbox"/> A3 $X \geq Y$	<input type="checkbox"/> E3 $X > 2Y$	<p>For A3, <math>X &gt; Y</math>                  For A3-2, <math>X &gt; Y, X &lt; 2Y</math>                  For B3, <math>X = 2Y</math>                  For E3, <math>X &gt; 2Y</math></p> <p>* Dimensions X and Y shown here are the proportions of available rectangular duct sizes. Duct sizes are available in 3" increments. Dimension X is always the longer dimension for each core option.</p>
	<input type="checkbox"/> A3-2 $X > Y, X < 2Y$	<input type="checkbox"/> B3 $X = 2Y$	
4 Way	<input type="checkbox"/> A4 Square	<input type="checkbox"/> B4	

## Removing Center Core

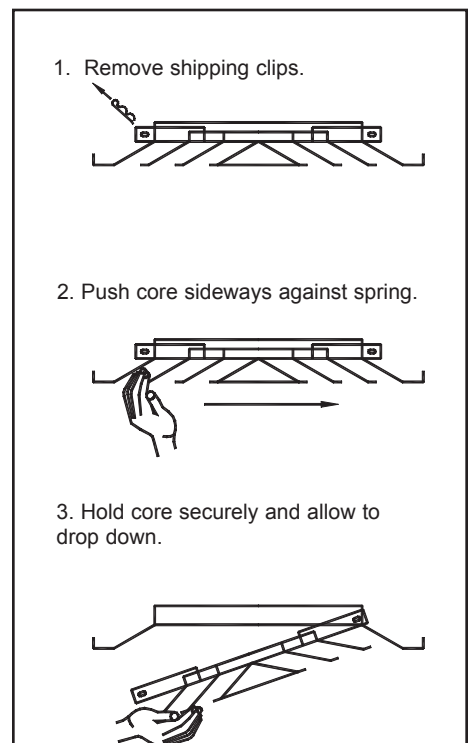

## General Description

- TITUS Model TDC-AA is a high capacity ceiling diffuser. Because it maintains an unbroken horizontal flow pattern from maximum cfm down to minimum, it is an excellent choice for variable air volume applications.
- Core is removable from the face of the diffuser.

- Lever operator on optional Model AG-95 damper allows easy volume adjustment from the face of the diffuser. (Rectangular necks only).
- Model TDC-AA is extremely flexible, with cores available for 1, 2, 3 or 4-way horizontal flow patterns.

- Material is aluminum with miscellaneous steel components.



Note: This submittal is meant to demonstrate general dimensions of this product. The drawings on this submittal are not meant to detail every aspect of the product with exactness. Drawings are not to scale. TITUS reserves the right to make changes without written notice.

605 Shiloh Road • Plano, Texas 75074 • 972-212-4800

D-40.0-S