

Redefine your comfort zone.™ | www.titus-hvac.com



single / dual duct terminals



seismic certified



m

Table of Contents

SINGLE/DUAL DUCT TERMINAL PRODUCTS

Single / Dual Duct Terminal Products	M3
--	----

SINGLE DUCT TERMINALS

ESV / ESV-S Single Duct	M5
Design Features	M5
Control Strategies	M7
ESV / ESV-S - Basic Unit with Controls	M9
Dimensions	M10
Accessories	M11
Performance Data	M15
Electric Coils	M22
AHRI Certification	M24

DUAL DUCT TERMINALS

EDV/MDV Dual Duct	M25
Design Features	M25
Control Strategies	M26
EDV / EDV-S - Dual Duct without Attenuator	M27
Dimensions	M28
Performance Data	M29
EDV/EDC - Dual Duct with Attenuator	M31
Dimensions	M32
Performance Data	M33
MDV/MDC - Dual Duct High Performance Blending	M35
Dimensions	M36
Performance Data	M37
AHRI Certification	M39

ICONS

Icons Key	M41
-----------------	-----

PAGES: M5-M23

single duct terminals

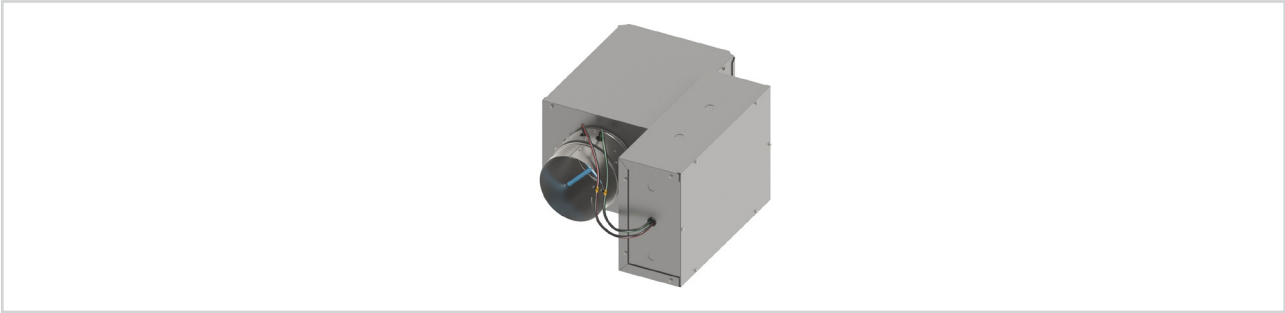

ESV / ESV-S

AVAILABLE CONFIGURATIONS

- With integral attenuator
- With water coils
- With integral electric coil section

CONTROL OPTIONS

- Pneumatic
- Electric
- TA1 electronic
- DDC controls
- Factory mounting of controls by others
- OEM controls (Titus Alpha BACnet)

UNIT ACCESSORIES

- EcoShield lining
- Fibre Free lining
- Steri-Loc™ lining
- UltraLoc lining
- Multi-outlet section
- Round outlet adapter
- Removable flow sensor
- Access door
- 20g construction
- Factory installed valve packages



For detailed controls information, please refer to the Terminal Unit Accessories section

PAGES: M24-M33

dual duct terminals

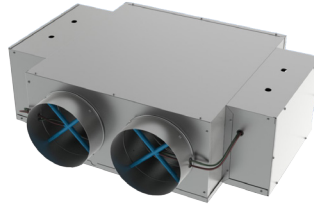

EDV / EDV-S

AVAILABLE CONFIGURATIONS

- Non-mixing
- With integral attenuator/mixing section
- Optional mixing baffle

CONTROL OPTIONS

- Pneumatic
- DDC controls
- Factory mounting of controls by others
- OEM controls (Titus Alpha BACnet)

UNIT ACCESSORIES

- EcoShield lining
- Fibre Free lining
- SteriLoc™ lining
- UltraLoc lining
- Removable flow sensor
- 20g construction

PAGES: M34-M38

dual duct terminals

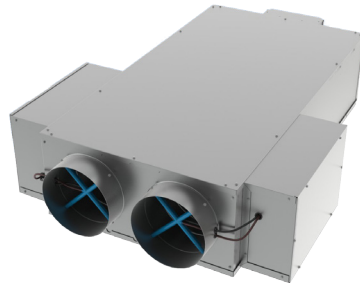

MDV

AVAILABLE CONFIGURATIONS

- Special high performance blending

CONTROL OPTIONS

- Pneumatic
- DDC controls
- Factory mounting of controls by others
- OEM controls (Titus Alpha BACnet)

UNIT ACCESSORIES

- EcoShield lining
- Fibre Free lining
- SteriLoc™ lining
- UltraLoc lining
- Removable flow sensor
- 20g construction

LEADING THE INDUSTRY: THE TITUS ESV SINGLE DUCT VAV TERMINAL

Single duct terminals are the fundamental building blocks for a variable air volume (VAV) system. Their primary function is to regulate airflow to a zone, in response to zone temperature requirements. The Titus ESV is unique as it incorporates many design features that increase performance, decrease installation and service cost and offers increased value, over and above this basic function.

All VAV terminals are not equal! By specifying the Titus ESV, you are assured of accurate, AHRI Certified performance ratings. All units are tested, and data shown, in accordance with AHRI Standards. A wide selection of unit configurations, accessories and control types provide considerable scope for problem solving and cost-effective innovation.

The ESV's compact size and easy access for service saves time and expense in installation. The ESV fits easily in cramped mechanical spaces, either in new building construction or retrofit.

Building owners will benefit from the energy efficient low leakage design, reducing utility expenses. Control accuracy, especially at minimum flow rates, is easier to achieve with a Titus multi-point inlet velocity sensor. Control accuracy is critical in maintaining good air quality reducing energy waste.

The ESV's standard insulation is a dual density liner. The skin resists abrasion and erosion from air movement. The body maximizes thermal and acoustical performance. The Titus single blade damper design helps reduce noise levels too, for a quieter work environment.

ESV Casing Leakage, cfm

INLET SIZE	Δ PS, IN WG			
	0.5	1.0	2.0	3.0
4, 5, 6	2	3	4	5
7, 8	4	5	7	9
9, 10	4	6	8	10
12	5	7	10	12
14	6	9	13	16
16	7	10	14	17

Damper Leakage, cfm

INLET SIZE	Δ PS, IN WG			
	1.0	2.0	4.0	6.0
4, 5, 6	3	4	6	7
7, 8	3	4	6	7
9, 10	3	4	6	7
12	3	4	6	7
14	3	5	7	8
16	4	5	7	9

MORE REASONS TO SPECIFY AND SELECT THE TITUS ESV:

Titus innovation carries through the widest array of standard single duct terminal configurations. ETL listed electric coils, manufactured by Titus, are installed, wired and functionally tested as an integral unit before shipment for quicker, trouble-free job-site installation. Multiple outlets with standard locking balancing dampers and integral attenuators are also available.

Titus continues to offer the most innovative and popular lining alternatives for special applications including Fibre Free; the industry benchmark SteriLoc; and the premium double wall liner, UltraLoc and EcoShield which is the only natural fiber insulation on the market.

Fibre Free eliminates the requirement for foil linings and solid inner liners since there is no fiberglass in the airstream. Additionally, Fibre Free minimizes mold growth since it holds no moisture, is acoustically preferable to foil or solid metal linings and maintains acceptable thermal protection. All of these benefits are available at a competitive price and significantly less than solid metal liners.

SteriLoc provides a smooth, nonporous skin to guard against mold and bacteria growth. Erosion is eliminated, as there is no glass fiber exposure to the airstream. It has reinforced surfaces that can be wiped down.

SteriLoc adds the feature of a very high density, rigid insulation and special "Z-Strip" construction for an extremely rigid terminal. Sound

Levels are generally superior to dual wall construction, while offering virtually identical levels of protection.

EcoShield is a sustainable liner comprised of recycled denim making it environmentally friendly and contains no harmful irritants or chemicals.

Titus - experts in DDC zone control!

With a detailed understanding developed through years of selling and supporting the powerful TD1 digital controller, and now the Titus BACnet OEM controls, Titus has industry leading experience in the application of Direct Digital Control (DDC) to terminals. This same expertise is made available when your project requires quality engineering, coordination and manufacturing for factory mounting when controls are supplied by others.

Count on Titus - the industry leader in VAV!

Titus adds flexibility to project schedules and execution by providing factory mounted valve packages to control hydronic heating. By removing expensive piece by piece on sight installation and utilizing lean manufacturing techniques provided by our state of the art manufacturing facilities, we can reduce expensive on sight labor cost during construction and decrease the overall time for installation. This will reduce the total installed cost to any building owner.

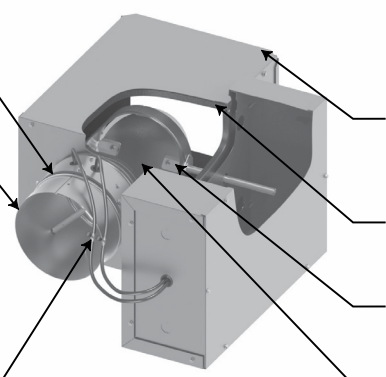

Removable flow sensor (optional)

Beaded inlet for consistent roundness and low leakage construction, sized to fit standard round duct

AeroCross™ multi-point, center averaging sensor amplifies flow signal for best control of low flow rates. Center averaging feature provides signal accuracy regardless of inlet duct configuration.

Flow measurement taps for easy balancing connections

DESV

Unique integral fold fabrication method increases lining and casing integrity and minimizes leakage

Standard insulation is 1/2 inch dual density fiberglass, to resist erosion at surface velocities up to 5,000 fpm. Meets requirements of NFPA 90A and UL181.

Delrin® damper bearings provide smoother damper operation

Damper design provides smoother airflow for reduced sound levels and lower leakage

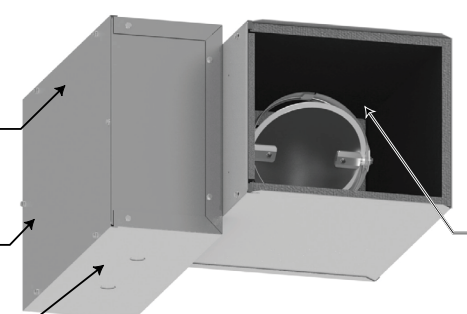

NEMA 1 control enclosure available for protection of electronic controls. Double backplane construction for strength and easier control installation, with no exposed screw tips for safe handling.

UL Class II transformers and disconnect switches available installed for use with any electronic control configuration

Multiple knockouts in sizes from 7/16-inch to 11/8-inch to accommodate almost any field connection requirement

DESV

Optional Fibre Free, reinforced sealed skin SteriLoc, or metal lined UltraLoc liners guard against environments favoring bacteria and mold growth. Fibre Free & EcoShield are ideal IAQ insulation providing acoustical and thermal characteristics of fiberglass insulation without the concern of fiberglass in the airstream. All liners meet UL 181 and NFPA 225 (25/50).

Variable Air Volume - VAV Cooling

As the room temperature increases over setpoint, the unit modulates the cold airflow from the minimum (which may be zero flow) to the maximum setting.

For detailed information on specific control types, refer to the following pages in Section O:

Pneumatic: See pg. 018 / Analog: See pg. 011 / Digital: See pg. 05

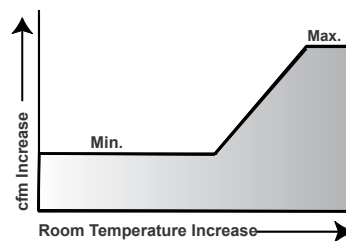

VAV Cooling, Hot Water Reheat

As the room temperature increases, the unit modulates the hot water coil valve toward the closed position. On a further increase in room temperature, the unit modulates the cold airflow from the minimum (which must be greater than zero) to the maximum setting.

Pneumatic: See pg. 018 / Analog: See pg. 011 / Digital: See pg. 05

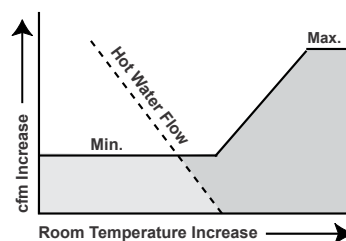

VAV Cooling, Dual Minimum Flows with Hot Water Reheat

In the cooling mode, as the room temperature increases, the unit thermostat modulates the cold airflow from the lower minimum to the maximum setting.

In the heating mode, the unit references the alternate (higher) minimum airflow. As the room temperature decreases, the unit modulates the airflow from the maximum to the higher minimum, then modulates the hot water coil valve toward the open position. The valve operates only in the heating mode.

Pneumatic: See pg. 018 / Analog: See pg. 011 / Digital: See pg. 05

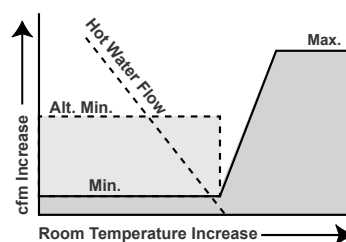

VAV Cooling and VAV Heating, Local Heat Flows

In the heating mode, as the room temperature increases, the unit modulates the airflow from maximum to minimum and modulates the hot water coil valve toward the closed position.

A further increase in room temperature changes the operation to the cooling mode, and the unit modulates the cold airflow from minimum to maximum, which is the same as the heating maximum.

Pneumatic: See pg. 018 / Analog: See pg. 011 / Digital: See pg. 05

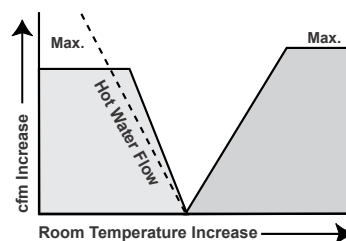

VAV Cooling and VAV Heating, Central Heat Flows

In the heating mode, as the room temperature increases, the unit modulates the airflow from maximum to minimum and modulates the hot water coil valve toward the closed position.

A further increase in room temperature changes the operation to the cooling mode, and the unit modulates the cold airflow from minimum to maximum, which is different from the heating maximum (usually higher). Both the heating and the cooling maximum airflows are adjustable.

Pneumatic: See pg. 018 / Analog: See pg. 011 / Digital: See pg. 05

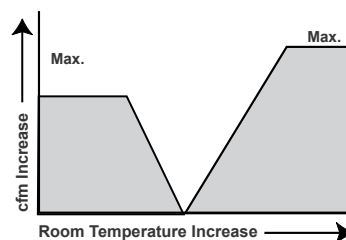

Constant Volume, Hot Water Reheat

The cold airflow remains constant regardless of changes in duct pressure or room temperature. As the room temperature increases, the unit modulates the hot water coil valve toward the closed position.

Pneumatic: See pg. 018 / Analog: See pg. 011 / Digital: See pg. 05

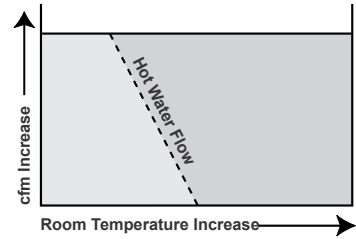

VAV Cooling, Electric Reheat

As the room temperature increases, the unit de-energizes the electric heating coil one step at a time. On a further increase in room temperature, the unit modulates the cold airflow from the minimum (which must be greater than zero) to the maximum setting.

Pneumatic: See pg. 018 / Analog: See pg. 011 / Digital: See pg. 05

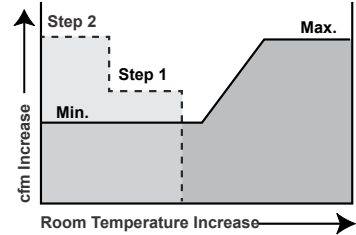

VAV Cooling, Dual Minimum Flows with Electric Reheat

In the cooling mode, as the room temperature increases, the room thermostat modulates the cold airflow from the lower minimum to the maximum setting.

In the heating mode, as the room temperature decreases, the unit modulates the airflow from the lower minimum to the higher minimum, then energizes the electric heating coil stages.

Pneumatic: See pg. 018 / Analog: See pg. 011 / Digital: See pg. 05

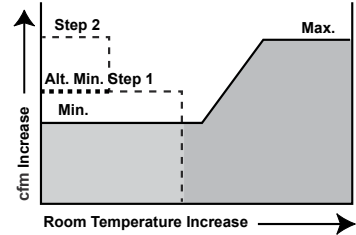

VAV Cooling with Morning Warmup

When provided the appropriate signal, the damper in the terminal modulates to maximum or fully open position. Heated air from the central system moves through the duct (the flow may be pressure dependent with some control types).

When the signal is removed, the unit resumes normal control of airflow. With the central system now supplying cold air, as room temperature increases, the unit modulates the cold airflow from minimum to the maximum setting.

Pneumatic: See pg. 018 / Analog: See pg. 011 / Digital: See pg. 05

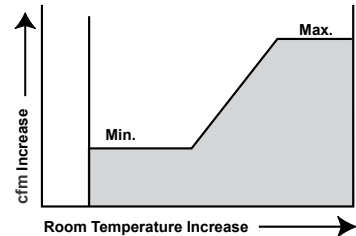

Single Duct Terminal Units

single / dual duct terminals

ESV / ESV-S

- ESV can be installed horizontally, vertically or at any angle; unit operation is not affected by position
- Choice of right or left hand control location
- Standard AeroCross multi-point center averaging velocity sensor (except EESV)
- Standard dual density insulation
- Controls supplied by Titus are factory calibrated for a quicker start-up
- Standard 22-gauge casing with slip and drive connection
- OSP & IBC seismic certifications available for ESV-S units with Titus pneumatic, analog, and digital controls

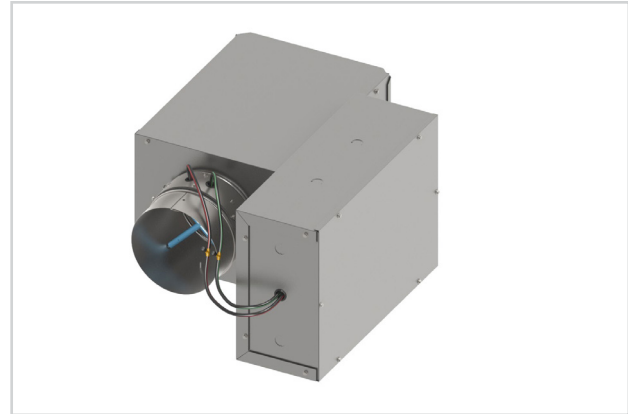

ESV



seismic certified

MODELS:

PESV / Pneumatic
EESV / Electric
AESV / Analog Electronic
DESV / Digital Electronic
ESV-S / Seismic Option
ESV-VP / Valve Package Option

OVERVIEW

Single Duct terminals are the fundamental building blocks for Variable Air Volume (VAV) systems. Their primary function is to regulate airflow to a zone, in response to zone temperature requirements. The Titus ESV is unique as it incorporates many design features that increase performance, decrease service and installation costs, and offer increased value, over and above this basic function.



See website for Specifications

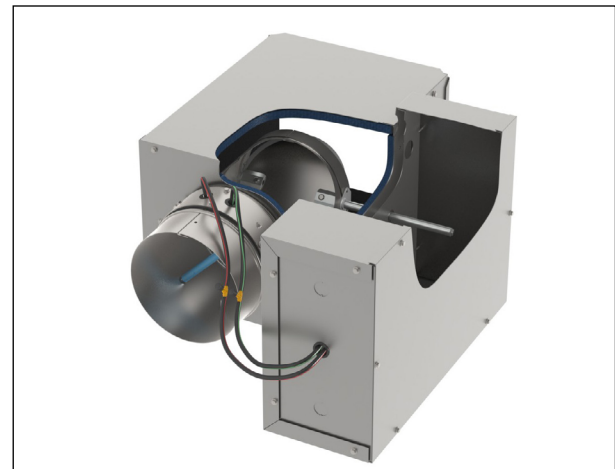

Cutaway view of the components for the ESV terminal unit

ESV UNIT DIMENSIONS

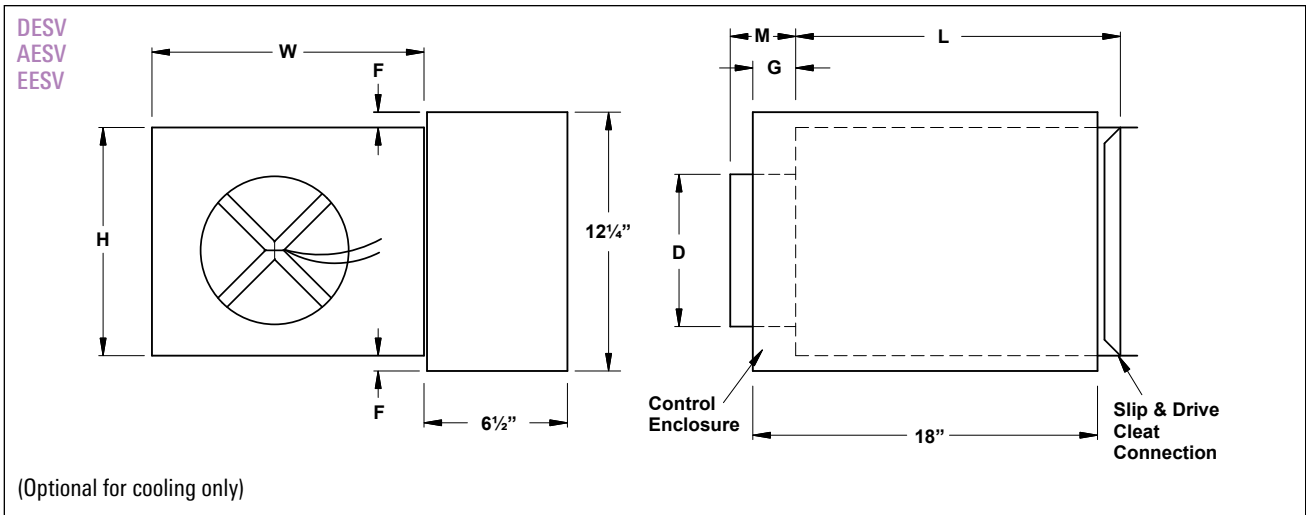
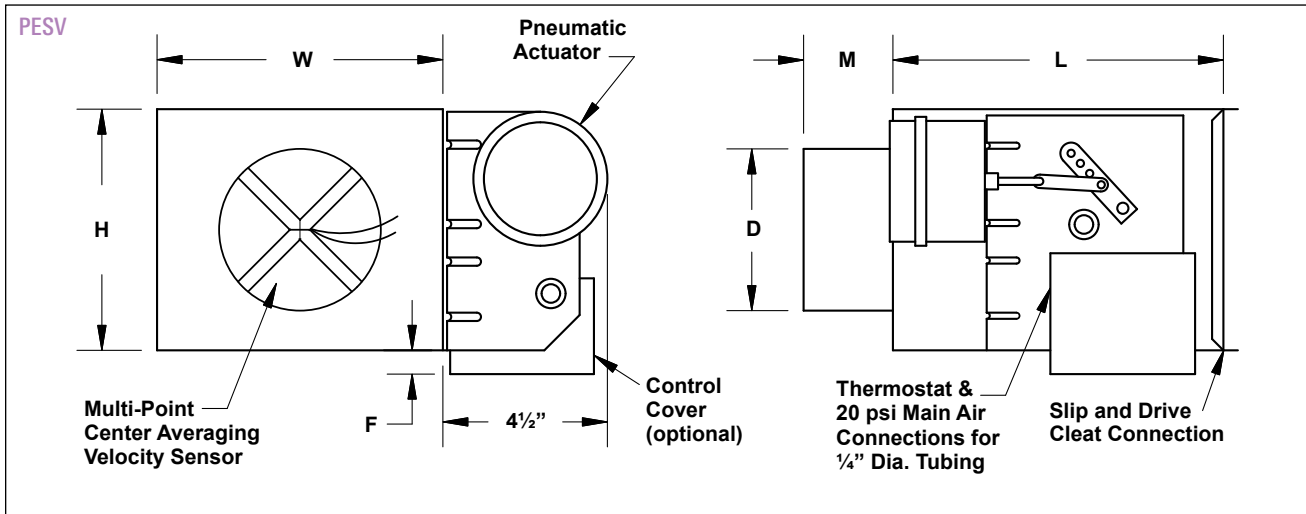

INLET SIZE	CFM RANGE	D	F		G	H	L	M	W
			PESV	AESV DESV EESV					
4	0-225	3 ⁷ / ₈	1 ⁷ / ₈	2 ¹ / ₈	7 ³ / ₈	8	15 ¹ / ₂	5 ³ / ₈	12
5	0-350	4 ⁷ / ₈	1 ⁷ / ₈	2 ¹ / ₈	7 ³ / ₈	8	15 ¹ / ₂	5 ³ / ₈	12
6	0-500	5 ⁷ / ₈	1 ⁷ / ₈	2 ¹ / ₈	7 ³ / ₈	8	15 ¹ / ₂	3 ³ / ₈	12
7	0-650	6 ⁷ / ₈	7 ⁷ / ₈	1 ¹ / ₈	7 ³ / ₈	10	15 ¹ / ₂	3 ³ / ₈	12
8	0-900	7 ⁷ / ₈	7 ⁷ / ₈	1 ¹ / ₈	7 ³ / ₈	10	15 ¹ / ₂	3 ³ / ₈	12
9	0-1050	8 ⁷ / ₈	-	-	5 ³ / ₈	12 ¹ / ₂	15 ¹ / ₂	3 ³ / ₈	14
10	0-1400	9 ⁷ / ₈	-	-	5 ³ / ₈	12 ¹ / ₂	15 ¹ / ₂	3 ³ / ₈	14
12	0-2000	11 ⁷ / ₈	-	-	5 ³ / ₈	15	15 ¹ / ₂	3 ³ / ₈	16
14	0-3000	13 ⁷ / ₈	-	-	3 ³ / ₈	17 ¹ / ₂	15 ¹ / ₂	3 ³ / ₈	20
16	0-4000	15 ⁷ / ₈	-	-	3 ³ / ₈	18	15 ¹ / ₂	3 ³ / ₈	24
24 x 16	0-8000	23 ⁷ / ₈ - 15 ⁷ / ₈	7 ⁷ / ₈	1 ¹ / ₈	5 ³ / ₈	18	15	3 ³ / ₈	38

INTEGRAL SOUND ATTENUATOR

Titus' unique integral design minimizes casing leakage and disturbance to airflow with no casing or insulation seams.

INTEGRAL ELECTRIC COIL

With a rigid one piece assembly, Titus locates the heating elements for optimal heat transfer and insets them for protection during shipment and installation.

STANDARD FEATURES:

- Primary automatic reset thermal cutout (one per coil)
- Secondary manual reset thermal cutout
- Airflow switch (differential pressure)
- De-rated nickel chrome heating elements
- Magnetic or safety contactors (as required)
- Line terminal block
- Control terminal block
- ETL listed
- 80/20 nickel chrome element wire

OPTIONAL FEATURES:

- Class II, 24 volt control transformer
- Door interlock disconnect switch
- Main supply fuses
- Dust tight construction
- Removable flow sensor

HOT WATER REHEAT COILS WITH VALVE PACKAGES

Titus offers a factory mounted valve package configuration to adapt to ever changing realities in construction. This configuration has all of the standard features, options, and performance as our industry leading single duct but has the added advantage of factory assembling and quality control to ensure a repeatable and reliable solution that can be difficult or expensive to achieve in field environments.

OPTIONAL FEATURES:

- 2-Way or 3-Way valve Types
- 2 position On-Off or Modulating fail in place
- Y-Strainer w/blow down
- 0-9 GPM flow rates

INTEGRAL SOUND ATTENUATOR WITH OPTIONAL HOT WATER REHEAT COIL

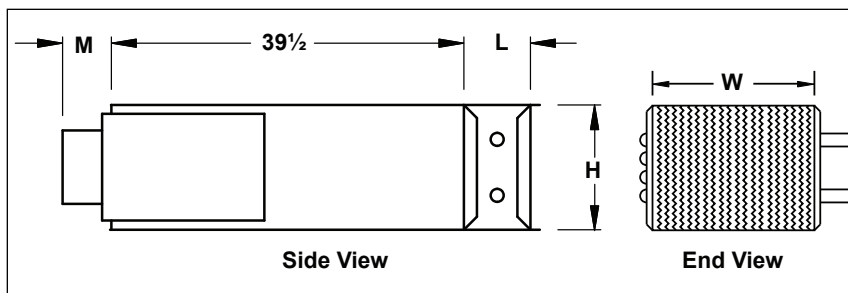
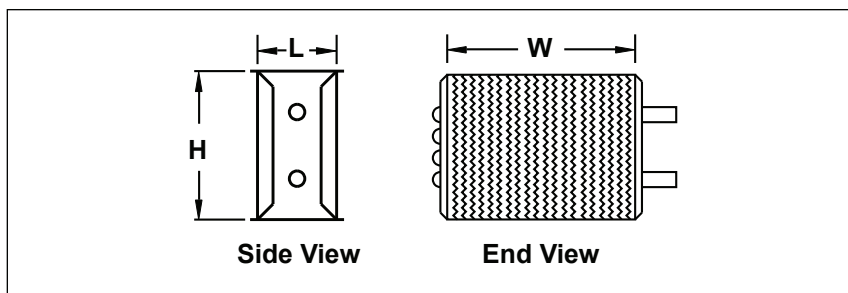
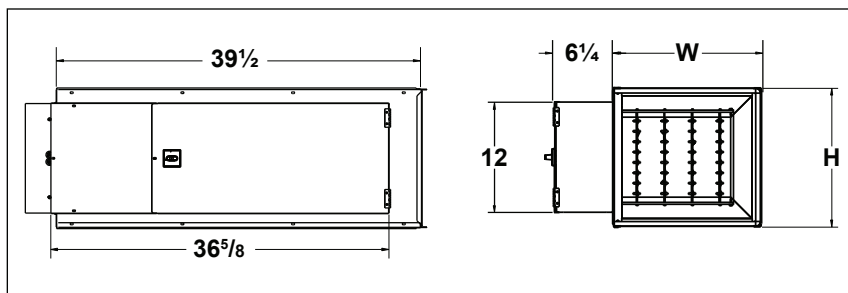
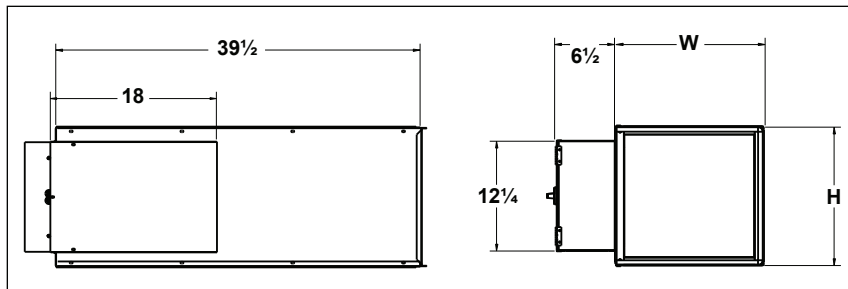

INLET SIZE	H	M	W	WATER COIL	
				L (1-2 ROW)	L (3-4 ROW)
4, 5	8	5 ³ / ₈	12	5	7 ¹ / ₄
6	8	3 ³ / ₈	12	5	7 ¹ / ₄
7, 8	10	3 ³ / ₈	12	5	7 ¹ / ₄
9, 10	2 ¹ / ₂	3 ³ / ₈	14	5	7 ¹ / ₄
12	15	3 ³ / ₈	16	5	7 ¹ / ₄
14	7 ¹ / ₂	3 ³ / ₈	20	7 ¹ / ₂	9 ³ / ₄
16	18	3 ³ / ₈	24	7 ¹ / ₂	9 ³ / ₄
24 x 16	18	3 ³ / ₈	38	5	7 ¹ / ₄

Note: The total length of the ESV basic unit and accessories (attenuators and coils) is the summation of basic unit length and the accessories length

ESV STANDARD WITH OPPOSITE SIDE VALVE PACKAGE

Single Duct Terminal Unit
Digital Control, Pressure Independent

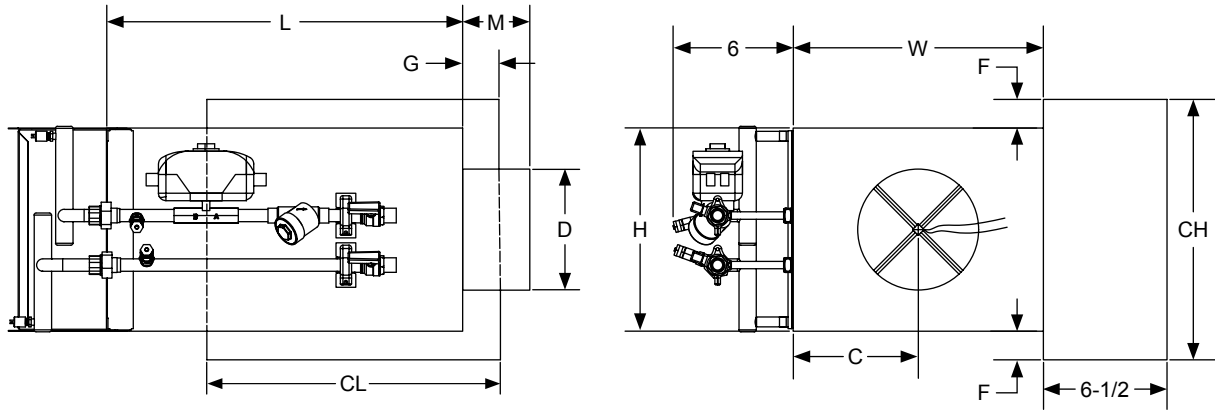

Right hand unit shown. All dimensions are in inches.

SIZE	CFM RANGE	D (H x W)	C	F	G	H	L	M	W	CH	CL
4	0-225	3 7/8	6 1/2	2 1/8	7 3/8	8	15 1/2	5 3/8	12	12 1/4	18
5	0-350	4 7/8	6 1/2	2 1/8	7 3/8	8	15 1/2	5 3/8	12	12 1/4	18
6	0-500	5 7/8	6 1/2	2 1/8	7 3/8	8	15 1/2	3 3/8	12	12 1/4	18
7	0-650	6 7/8	6	1 1/8	7 3/8	10	15 1/2	3 3/8	12	12 1/4	18
8	0-900	7 7/8	6	1 1/8	7 3/8	10	15 1/2	3 3/8	12	12 1/4	18
9	0-1050	8 7/8	7	-	5 3/8	12 1/2	15 1/2	3 3/8	14	12 1/4	18
10	0-1400	9 7/8	7	-	5 3/8	12 1/2	15 1/2	3 3/8	14	12 1/4	18
12	0-2000	11 7/8	8	-	5 3/8	15	15 1/2	3 3/8	16	12 1/4	18
14	0-3000	13 7/8	10 1/2	-	3 3/8	17 1/2	15 1/2	3 3/8	20	12 1/4	18
16	0-4000	15 7/8	13 1/2	-	3 3/8	18	15 1/2	3 3/8	24	12 1/4	18
20	0-2000	7 1/2 x 12 1/4	8	1/4	3	10	15 1/2	3 3/8	16	12 1/4	15 1/4
40	0-8000	15 7/8 x 23 7/8	19	1 1/8	5 3/8	18	15	3 3/8	38	12 1/4	18
5E	0-350	4 7/8	6	2 1/8	7 3/8	10	15 1/2	3 3/8	12	12 1/4	18
6E	0-500	5 7/8	6	2 1/8	7 3/8	10	15 1/2	3 3/8	12	12 1/4	18
7E	0-650	6 7/8	7	1 1/8	5 3/8	12 1/2	15 1/2	3 3/8	14	12 1/4	18
8E	0-900	7 7/8	7	1 1/8	5 3/8	12 1/2	15 1/2	3 3/8	14	12 1/4	18
1E	0-1400	9 7/8	8	-	5 3/8	15	15 1/2	3 3/8	16	12 1/4	18
2E	0-2000	11 7/8	10 1/2	-	3 3/8	17 1/2	15 1/2	3 3/8	20	12 1/4	18
4E	0-3000	13 7/8	13 1/2	-	3 3/8	18	15 1/2	3 3/8	24	12 1/4	18

MULTI-OUTLET PLENUMS FOR SINGLE DUCT TERMINALS

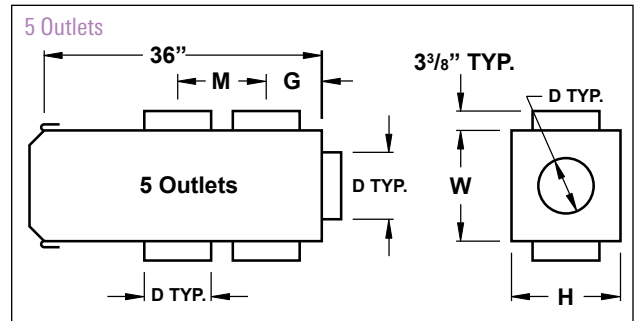
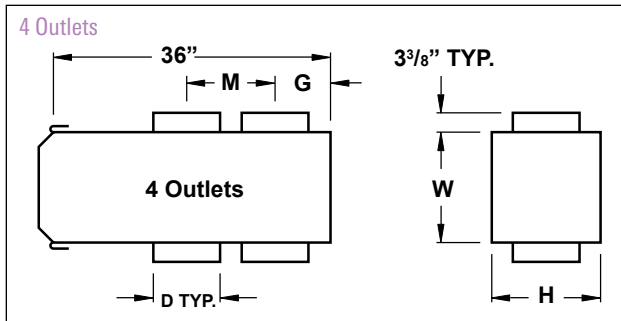
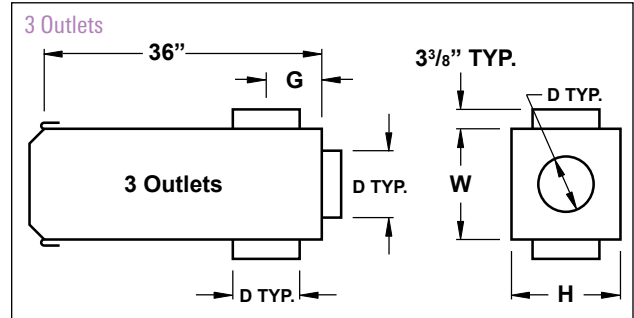
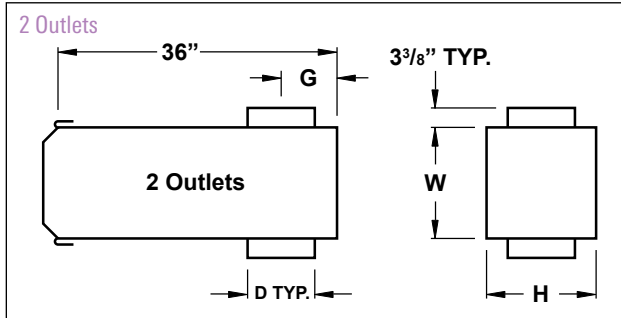

ESV Unit Sizes	Outlet Size D	2 Outlets		3 Outlets		4 Outlets		5 Outlets		H	W
		G	M	G	M	G	M	G	M		
4, 5, 6	5 ⁷ / ₈	4 ³ / ₈	-	4 ³ / ₈	-	-	-	-	-	8	12
7, 8	7 ⁷ / ₈	5 ³ / ₈	-	5 ³ / ₈	-	5 ³ / ₈	12	-	-	10	12
8	7 ⁷ / ₈	-	-	-	-	-	-	5 ³ / ₈	12	10	12
9, 10	9 ⁷ / ₈	5 ³ / ₈	-	5 ³ / ₈	-	5 ³ / ₈	14	-	-	12 ¹ / ₂	14
9, 10	7 ⁷ / ₈	-	-	5 ³ / ₈	-	5 ³ / ₈	12	-	-	12 ¹ / ₂	14
12	1 ⁷ / ₈	6 ³ / ₈	-	6 ³ / ₈	-	-	-	-	-	15	16
12	9 ⁷ / ₈	-	-	6 ³ / ₈	-	6 ³ / ₈	14	6 ³ / ₈	14	15	16
14	1 ⁷ / ₈	6 ³ / ₈	-	6 ³ / ₈	-	-	-	-	-	17 ¹ / ₂	20
14	9 ⁷ / ₈	-	-	6 ³ / ₈	-	6 ³ / ₈	14	6 ³ / ₈	14	17 ¹ / ₂	20
16	1 ⁷ / ₈	6 ³ / ₈	-	6 ³ / ₈	-	-	-	-	-	18	24
16	9 ⁷ / ₈	-	-	6 ³ / ₈	-	6 ³ / ₈	14	6 ³ / ₈	14	18	24

ROUND OUTLETS

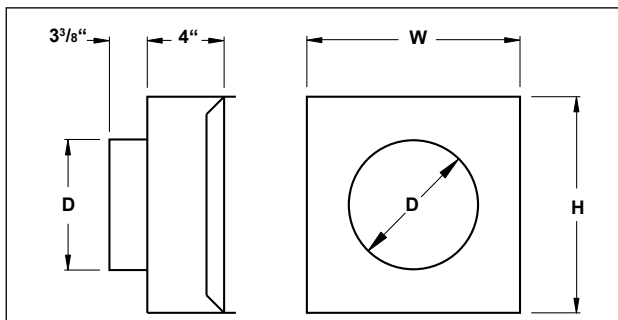

Unit Size	D	H	W
4	3 ⁷ / ₈	8	12
5	4 ⁷ / ₈	8	12
6	5 ⁷ / ₈	8	12
7	6 ⁷ / ₈	10	12
8	7 ⁷ / ₈	10	12
9	8 ⁷ / ₈	12 ¹ / ₂	14
10	9 ⁷ / ₈	12 ¹ / ₂	14
12	11 ⁷ / ₈	15	16
14	13 ⁷ / ₈	17 ¹ / ₂	20
16	15 ⁷ / ₈	18	24

REMOVABLE FLOW SENSOR

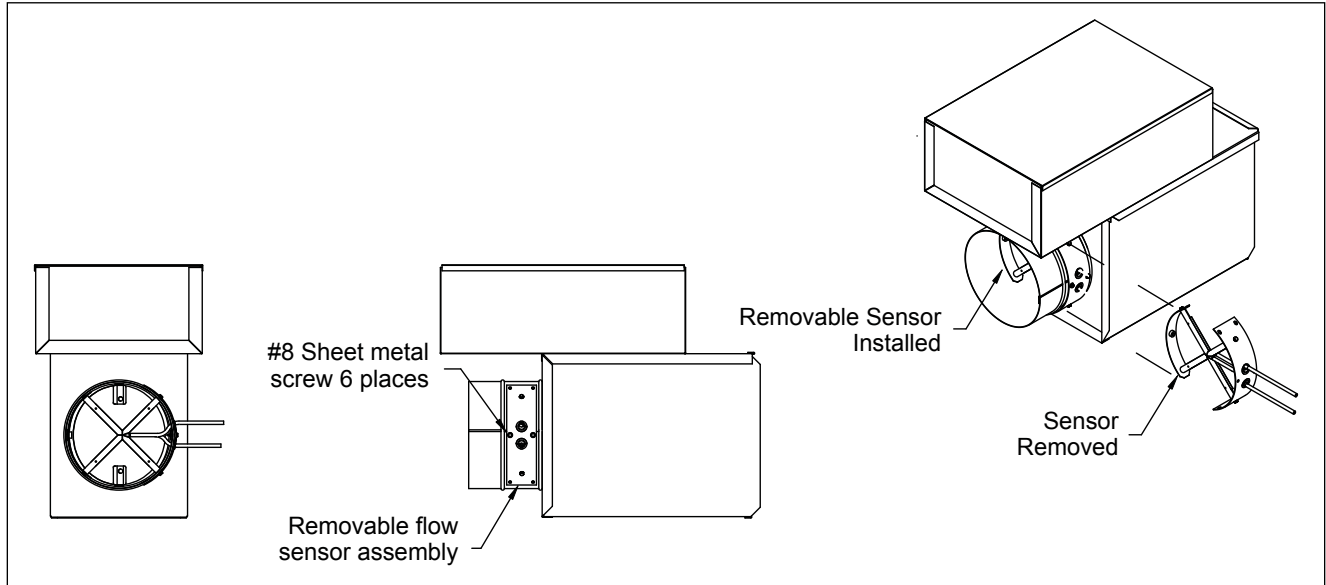

ESV WITH ACCESS DOOR OPTION

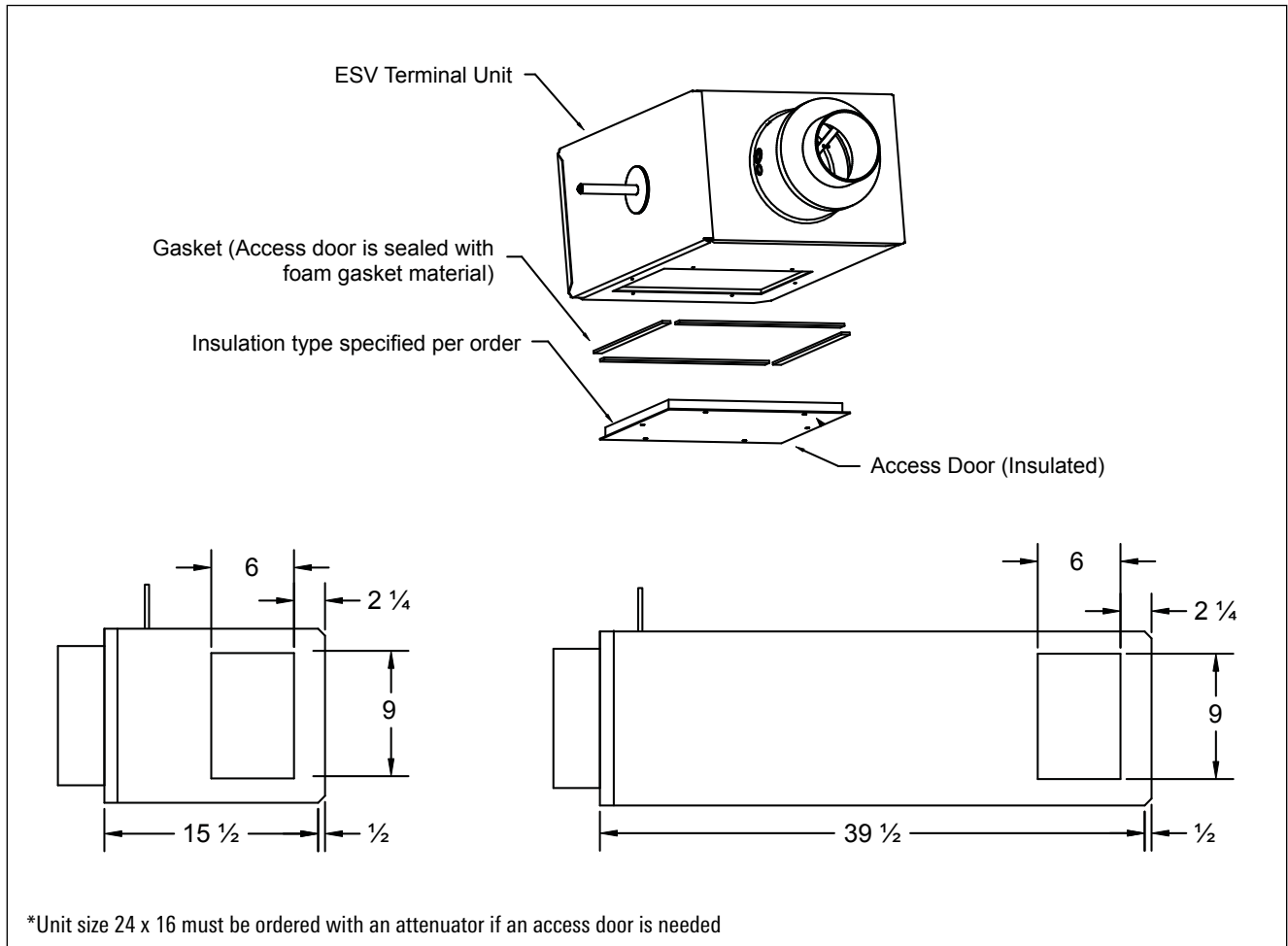

*Unit size 24 x 16 must be ordered with an attenuator if an access door is needed

RECOMMENDED PRIMARY AIR CFM RANGES / ALL TERMINALS

Control Types:

- PESV / Pneumatic
- AESV / Analog Electronic
- DESV / Digital Electronic

QUICK SELECTION PROCEDURE

1. Select unit inlet size based upon acoustic parameters and/or maximum pressure drop requirements, using pages M15-M16
2. Check inlet size selection against cfm control limits based on control type shown on this page
3. Select accessories (multi-outlets, attenuators) as required
4. Select reheat coil, if required. Make your selection using the actual heating flow rate, not cooling.

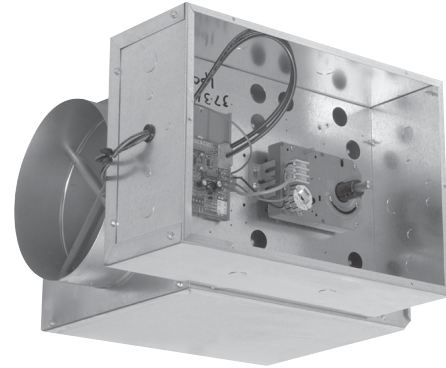

Inlet Size	Total CFM Range	CFM Ranges of Minimum and Maximum Settings							
		PESV - Pneumatic Titus II Controller		PESV - Pneumatic Titus I Controller		AESV - Analog Electronic TA1 Controller		DESV - Digital Typical Controller	
		Minimum	Maximum	Minimum	Maximum	Minimum	Maximum	Minimum	Maximum
4	0-225	50-210	90-225	65-210	90-225	50-225	50-225	30-225	30-225
5	0-350	70-300	125-350	90-300	125-350	70-350	70-350	40-350	40-350
6	0-500	80-345	145-500	100-345	145-500	80-500	80-500	45-500	45-500
7	0-650	120-515	210-650	150-515	210-650	120-650	120-650	70-650	70-650
8	0-900	160-700	285-900	205-700	285-900	160-900	160-900	90-900	90-900
9	0-1050	205-900	370-1050	260-900	370-1050	205-1050	205-1050	120-1050	120-1050
10	0-1400	250-1110	455-1400	325-1110	455-1400	250-1400	250-1400	145-1400	145-1400
12	0-2000	330-1460	600-2000	425-1460	600-2000	330-2000	330-2000	190-2000	190-2000
14	0-3000	525-2335	955-3000	675-2335	955-3000	525-3000	525-3000	300-3000	300-3000
16	0-4000	665-2970	1215-4000	860-2970	1215-4000	665-4000	665-4000	385-4000	385-4000
24 X 16	0-8000	1245-5555	2270-8000	1605-5555	2270-8000	1245-8000	1245-8000	720-8000	720-8000

Note: On controls mounted by Titus but supplied by others (FMA or Factory Mounting Authorization), these values are guidelines only. Controls mounted on an FMA basis are calibrated in the field.

PESV, AESV, DESV / RADIATED SOUND PERFORMANCE

Size	CFM	Min ΔPs	Octave Band Sound Power, Lw																											
			0.5" ΔPs							1.0" ΔPs							1.5" ΔPs							2.0" ΔPs						
			2	3	4	5	6	7	NC	2	3	4	5	6	7	NC	2	3	4	5	6	7	NC	2	3	4	5	6	7	NC
4	100	0.02	49	45	36	33	31	26	11	52	48	39	36	35	31	15	53	50	41	37	37	34	17	55	51	43	38	39	36	18
	125	0.03	52	49	39	36	32	27	16	55	52	42	38	36	32	20	57	54	44	40	39	36	22	58	55	45	41	40	38	23
	150	0.04	55	52	41	37	34	28	15	58	55	44	40	38	34	23	60	57	46	41	40	37	25	61	58	47	42	42	39	27
	175	0.06	58	55	42	39	35	29	23	61	58	46	42	39	34	27	63	59	48	43	41	38	28	64	61	49	44	43	40	30
	200	0.08	60	57	44	40	36	30	25	63	60	47	43	40	35	29	65	62	49	44	42	38	31	66	63	51	45	44	41	33
5	150	0.01	49	44	36	32	31	25	10	53	49	41	36	35	30	16	55	51	43	38	37	33	18	57	53	45	39	39	35	21
	200	0.02	53	48	39	35	34	27	15	56	53	44	38	37	32	21	59	55	46	40	40	35	23	60	57	48	42	41	37	25
	250	0.03	55	52	41	37	35	29	20	59	56	46	40	39	34	24	62	59	49	42	41	37	28	63	61	51	44	43	39	30
	300	0.04	58	54	43	39	37	30	22	62	59	48	42	41	35	28	64	61	50	44	43	38	30	65	63	52	45	44	40	33
	350	0.06	60	56	45	40	38	31	24	63	61	49	43	42	36	30	66	63	52	45	44	39	33	67	65	54	47	45	41	35
6	300	0.07	55	49	40	35	32	28	16	59	54	45	39	37	33	22	61	57	48	41	39	36	25	63	59	50	42	41	38	28
	350	0.10	57	52	42	37	34	29	20	60	57	47	41	38	34	25	62	59	50	43	40	37	28	64	62	52	44	42	39	31
	400	0.13	58	53	44	39	35	30	21	61	58	49	42	39	35	27	63	61	52	44	42	38	30	65	63	54	46	43	40	33
	450	0.16	59	55	45	40	36	31	23	62	60	50	44	40	36	29	64	63	53	46	43	39	33	66	65	55	47	45	41	35
	500	0.20	59	56	47	42	37	32	24	63	61	51	45	41	37	30	65	64	54	47	44	40	34	67	67	56	49	46	42	37
7	450	0.07	59	48	42	38	33	24	20	61	54	48	42	38	30	23	62	57	51	45	41	33	25	63	59	53	46	43	35	28
	500	0.09	60	50	43	39	34	24	22	62	55	49	43	39	30	24	63	58	52	46	42	34	27	64	60	54	48	44	36	29
	550	0.10	60	51	44	40	35	25	22	63	57	50	45	40	31	25	64	59	53	47	43	34	28	66	62	55	49	45	37	31
	600	0.12	61	53	45	42	35	25	23	63	58	51	46	41	31	27	65	61	54	48	44	35	30	66	63	56	50	46	37	33
	650	0.15	62	54	46	43	36	26	24	64	59	52	47	41	32	28	65	62	55	49	44	35	31	66	64	57	51	46	38	34
8	600	0.02	59	50	44	40	38	32	20	62	55	49	43	43	39	24	64	58	52	46	45	44	27	65	60	54	47	47	47	29
	650	0.02	60	51	44	41	39	32	22	63	56	50	44	44	40	25	65	59	53	47	46	45	28	66	61	55	48	48	48	30
	700	0.02	60	52	45	42	40	33	22	63	57	50	45	44	41	25	65	60	53	47	47	45	29	67	62	56	49	49	48	31
	750	0.02	61	53	46	43	40	34	23	64	58	51	46	45	41	27	66	61	54	48	48	46	30	67	63	56	50	50	49	33
	800	0.03	62	54	47	43	41	34	24	65	59	52	47	46	42	28	66	62	55	49	48	47	31	68	64	57	51	50	50	34
9	800	0.04	58	47	43	36	34	30	19	61	53	49	42	40	35	23	62	57	52	46	44	38	26	63	59	55	48	47	40	29
	850	0.04	58	48	43	37	34	31	19	61	54	49	43	41	35	23	63	58	53	46	45	38	27	64	60	55	49	47	40	29
	900	0.05	59	49	44	37	35	31	20	62	55	50	43	41	35	24	64	58	53	47	45	38	27	65	61	56	49	48	40	30
	950	0.06	59	50	44	37	35	31	20	62	56	50	43	42	36	24	64	59	54	47	45	38	28	65	62	56	49	48	40	31
	1000	0.06	60	50	44	38	36	31	22	63	56	50	44	42	36	25	65	60	54	47	46	39	29	66	62	57	50	48	40	31
10	900	0.01	60	50	47	45	42	29	22	63	57	53	50	48	37	27	65	60	57	53	52	41	31	67	63	59	56	54	44	34
	1000	0.01	60	51	48	46	43	30	22	64	58	54	51	49	38	28	66	61	57	54	53	42	31	67	64	59	56	55	45	34
	1100	0.01	61	52	48	47	44	32	23	65	58	54	52	50	39	28	67	62	57	55	54	43	31	68	64	60	57	56	46	35
	1200	0.01	62	53	48	47	45	32	24	65	59	54	53	51	40	28	67	63	58	56	55	44	33	69	65	60	58	57	47	35
	1300	0.01	63	54	49	48	45	33	25	66	60	55	53	52	41	29	68	63	58	56	55	45	33	69	66	61	58	58	48	36
12	1200	0.01	58	50	47	41	37	30	20	62	56	52	47	43	37	26	64	59	56	50	46	41	30	66	61	58	53	49	43	32
	1400	0.01	60	52	48	42	38	32	22	63	57	54	48	45	39	28	65	60	57	52	48	42	31	67	63	60	54	51	45	35
	1600	0.01	61	53	50	43	40	34	24	64	59	55	49	46	40	29	66	62	59	53	50	44	34	68	64	61	55	52	47	36
	1800	0.01	61	55	51	44	41	35	25	65	60	56	50	48	41	30	67	63	60	54	51	45	35	69	65	62	56	54	48	37
	2000	0.01	62	56	52	45	43	36	26	66	61	57	51	49	43	31	68	64	61	55	52	47	36	69	67	63	57	55	49	38
14	1500	0.02	56	51	45	43	40	36	18	60	56	50	48	45	41	24	62	59	53	51	48	45	28	64	61	55	53	50	47	30
	1800	0.03	58	53	46	44	41	36	21	62	58	51	49	46	42	27	64	60	54	52	49	45	29	66	63	56	54	51	48	33
	2100	0.04	59	54	47	45	42	37	22	63	59	52	50	47	43	28	66	62	55	53	50	46	31	67	64	58	55	52	49	34
	2400	0.05	60	55	48	46	43	38	23	64	60	53	51	48	43	29	67	63	56	54	51	47	33	69	65	58	56	53	49	35
	2700	0.06	62	56	49	47	44	38	24	66	61	54	52	49	44	30	68	64	57	55	52	47	34	70	66	59	57	54	50	36
16	2000	0.02	55	48	43	41	39	31	36	59	53	47	45	44	38	21	61	56	50	47	47	41	24	63	58	52	49	49	44	27
	2400	0.02	57	51	45	43	41	33	18	61	56	49	47	46	39	24	64	59	52	49	49	43	28	65	61	54	51	51	46	30
	2800	0.03	59	53	46	44	42	34	21	63	58	51	48	47	41	27	66	61	54	50	50	45	30	67	63	55	52	52	48	33
	3200	0.04	61	55	48	46	44	36	23	65	60	52	50	49	42	29	67	62	55	52	52	46	31	69	64	57	53	54	49	34
	3600	0.05	62	56	49	47	45	37	24	66	61	54	51	50	44	30	69	64	56	53	53	48	34	71	66	58	55	55	50	36
40	3900	0.03	70	65	63	59	57	54	38	72	68	66	62	61	58	41	74	69	67	63	63	61	42	75	70	68	64	65	63	43
	4600	0.04	73	68	66	62	59	55	41	75	71	68	64	63	60	43	77	72	70	66	65	63	46	78	73	71	67	67	64	47
	5300	0.06	75	71	68	64	61	56	43	78	73	71	66	65	61	47	79	74	72	68	67	64	48	80	75	73	69	68	66	49
	6000	0.07	77	73	71	66	63	57	47	80	75	73	68	66	62	49	81	76	74	70										

PESV, AESV, DESV / HOT WATER COIL CAPACITY, MBH / 1- AND 2-ROW

Redefine your comfort zone.™ | www.titus-hvac.com

Rows	gpm	Head Loss	Airflow, CFM									
			50	100	150	200	250	300	350	400	450	
One-Row	1.0	0.48	3.7	5.6	6.8	7.8	8.6	9.3	9.9	10.4	10.8	
	2.0	1.82	3.8	5.9	7.3	8.5	9.5	10.3	11.0	11.6	12.2	
	4.0	6.98	3.9	6.1	7.6	8.9	10.0	10.9	11.7	12.4	13.1	
	5.0	10.75	3.9	6.1	7.7	9.0	10.1	11.0	11.8	12.6	13.3	
	Airside ΔPs		0.01	0.01	0.02	0.04	0.05	0.07	0.10	0.12	0.15	
Two-Row	1.0	0.12	5.0	8.1	10.3	12.0	13.4	14.5	15.5	16.3	17.0	
	3.0	1.04	5.4	9.0	11.9	14.2	16.2	17.9	19.4	20.7	22.0	
	5.0	2.80	5.4	9.2	12.2	14.7	16.9	18.8	20.5	22.0	23.4	
	7.0	5.38	5.5	9.3	12.4	15.0	17.3	19.2	21.0	22.6	24.1	
	Airside ΔPs		0.01	0.03	0.05	0.08	0.12	0.16	0.21	0.26	0.32	

Rows	gpm	Head Loss	Airflow, CFM								
			100	200	300	400	500	600	700	800	900
One-Row	1.0	0.64	6.2	8.9	10.7	12.1	13.1	14.0	14.7	15.3	15.9
	2.0	2.46	6.6	9.7	11.8	13.5	14.8	16.0	16.9	17.8	18.5
	3.0	5.38	6.7	10.0	12.3	14.1	15.5	16.8	17.9	18.8	19.7
	4.0	9.39	6.8	10.1	12.5	14.4	15.9	17.2	18.4	19.4	20.3
	Airside ΔPs		0.01	0.02	0.05	0.07	0.11	0.15	0.19	0.24	0.30
Two-Row	1.0	0.17	8.8	13.4	16.3	18.5	20.2	21.5	22.6	23.6	24.4
	3.0	1.40	9.7	15.6	20.0	23.4	26.3	28.6	30.7	32.5	34.1
	5.0	3.77	9.9	16.2	21.0	24.8	28.0	30.8	33.2	35.3	37.2
	7.0	7.24	10.0	16.5	21.4	25.5	28.8	31.8	34.4	36.7	38.8
	Airside ΔPs		0.02	0.05	0.10	0.16	0.23	0.32	0.41	0.51	0.62

Rows	gpm	Head Loss	Airflow, CFM								
			200	300	400	500	600	700	800	900	1000
One-Row	2.0	0.41	11.0	13.5	15.4	17.0	18.3	19.5	20.5	21.3	22.1
	3.0	0.90	11.4	14.1	16.3	18.1	19.6	20.9	22.0	23.0	23.9
	5.0	2.41	11.8	14.7	17.1	19.0	20.7	22.2	23.5	24.6	25.7
	6.0	3.43	11.9	14.9	17.3	19.3	21.0	22.5	23.9	25.1	26.2
	Airside ΔPs		0.01	0.02	0.04	0.06	0.08	0.10	0.13	0.15	0.19
Two-Row	2.0	0.47	16.4	21.0	24.5	27.4	29.8	31.8	33.6	35.1	36.5
	4.0	1.84	17.6	23.0	27.3	31.0	34.2	36.9	39.4	41.5	43.5
	6.0	4.08	18.0	23.8	28.5	32.5	36.0	39.1	41.8	44.3	46.6
	8.0	5.00	18.3	24.2	29.1	33.3	37.0	40.3	43.2	45.9	48.3
	Airside ΔPs		0.03	0.05	0.09	0.12	0.17	0.22	0.27	0.33	0.40

Rows	gpm	Head Loss	Airflow, CFM								
			300	500	700	900	1100	1300	1500	1700	1900
One-Row	2.0	0.54	15.5	19.8	22.9	25.2	27.1	28.7	30.1	31.2	32.3
	3.0	1.19	16.2	21.0	24.5	27.2	29.5	31.4	33.0	34.5	35.7
	5.0	3.18	16.9	22.1	26.0	29.1	31.7	34.0	35.9	37.6	39.2
	6.0	4.52	17.0	22.4	26.5	29.7	32.4	34.7	36.7	38.5	40.1
	Airside ΔPs		0.01	0.03	0.06	0.09	0.13	0.17	0.22	0.27	0.33
Two-Row	2.0	0.55	23.2	30.8	36.2	40.2	43.5	46.1	48.3	50.2	51.9
	4.0	2.15	25.3	34.8	41.9	47.6	52.3	56.3	59.7	62.7	65.4
	6.0	4.75	26.1	36.4	44.3	50.7	56.1	60.8	64.8	68.4	71.6
	8.0	6.16	26.5	37.2	45.6	52.5	58.3	63.3	67.8	71.7	75.3
	Airside ΔPs		0.03	0.07	0.13	0.20	0.27	0.36	0.46	0.57	0.68

M

PERFORMANCE DATA

PESV, AESV, DESV / HOT WATER COIL CAPACITY, MBH / 1- AND 2-ROW

Rows	gpm	Head Loss	Airflow, CFM									
			400	700	1000	1300	1600	1900	2200	2500	2800	
One-Row	2.0	0.43	20.4	26.3	30.3	33.2	35.5	27.4	39.0	40.4	41.5	
	3.0	0.96	21.6	28.4	33.2	36.8	39.7	42.0	44.1	45.9	47.4	
	5.0	2.63	22.7	30.5	36.0	40.3	43.8	47.8	49.3	51.6	53.6	
	6.0	3.77	23.1	31.0	36.8	41.3	45.0	48.2	50.9	53.3	55.4	
	Airside ΔPs		0.01	0.03	0.06	0.09	0.13	0.17	0.22	0.27	0.33	
Two-Row	2.0	0.39	30.1	40.3	47.0	51.8	55.5	58.5	60.9	62.9	64.7	
	4.0	1.51	33.5	47.1	56.8	64.3	70.3	75.3	79.6	83.2	86.4	
	6.0	3.36	34.9	49.9	61.1	69.9	77.2	83.3	88.6	93.2	97.3	
	8.0	3.95	35.6	51.5	63.5	73.1	81.1	88.0	93.9	99.2	103.8	
	Airside ΔPs		0.03	0.07	0.12	0.19	0.27	0.36	0.46	0.57	0.69	

Rows	gpm	Head Loss	Airflow, CFM								
			600	1000	1400	1800	2200	2600	3000	3400	3800
One-Row	3.0	1.07	29.5	37.4	42.8	47.0	50.4	53.1	55.5	57.5	59.3
	5.0	2.92	31.4	40.6	47.2	52.3	56.5	60.1	63.1	65.8	68.2
	7.0	5.65	32.4	42.1	49.3	55.0	59.7	63.7	67.1	70.2	72.9
	9.0	6.48	32.9	43.1	50.6	56.6	61.6	65.9	69.6	72.9	75.9
	Airside ΔPs		0.02	0.04	0.07	0.10	0.14	0.19	0.24	0.30	0.36
Two-Row	3.0	0.53	43.1	55.9	64.7	71.1	76.1	80.1	83.4	86.2	88.6
	5.0	1.46	47.0	63.1	74.6	83.5	90.7	96.6	101.6	105.9	109.7
	7.0	2.84	49.0	66.8	80.0	90.3	98.8	106.0	112.1	117.5	122.2
	9.0	2.54	50.2	69.0	83.3	94.6	104.1	112.1	119.0	125.1	130.5
	Airside ΔPs		0.04	0.08	0.14	0.22	0.30	0.40	0.51	0.63	0.76

Rows	gpm	Head Loss	Airflow, CFM								
			600	1200	1800	2400	3000	3600	4200	4800	5400
One-Row	3.0	1.31	35.3	49.4	58.3	64.7	69.6	73.5	76.8	79.6	82.0
	5.0	3.57	37.6	54.2	65.2	73.4	79.9	85.3	89.9	93.8	97.3
	7.0	6.89	38.7	56.5	68.7	77.9	85.4	91.6	96.9	101.5	105.6
	9.0	8.50	39.3	58.0	70.8	80.7	88.7	95.5	101.3	106.4	110.9
	Airside ΔPs		0.01	0.02	0.05	0.08	0.11	0.15	0.20	0.25	0.30
Two-Row	3.0	0.59	48.8	70.9	84.3	93.4	100.1	105.3	109.4	112.8	115.7
	5.0	1.63	53.1	81.0	99.4	112.9	123.3	131.6	138.5	144.3	149.3
	7.0	3.17	55.2	86.2	107.6	123.8	136.6	147.1	155.9	163.5	170.0
	9.0	3.06	56.4	89.4	112.8	130.8	145.3	157.3	167.5	176.4	184.2
	Airside ΔPs		0.02	0.05	0.10	0.16	0.24	0.32	0.42	0.52	0.63

- All coil performance in accordance with AHRI 410-2001
- Heating capacities are in MBH
- Data based on 180°F entering water and 55°F entering air
- For temperature differentials other than 125°, multiply MBH by correction factors below
- Head loss is in feet of water
- Always supply water to lowest connection pipe to prevent air entrapment
- Air temperature rise = 927 x MBH/cfm
- Water temperature drop = 2.04 x MBH/gpm
- Connection size is ½ OD male solder for 1-row coil sizes 04-08. All other coils have 7/8" OD male solder.
- Coils are not intended for steam applications and are labeled for a maximum water temperature of 200°F
- Coils are tested for leakage at test pressure of 500 psi
- Water volumes less than those shown may result in laminar flow and reduced heating capacity. If possible reduce the number of coil rows to increase water velocity into turbulent range.

Correction Factors for Other Entering Conditions

ΔT	50	60	70	80	90	100	110	125	140	150
Factor	0.40	0.48	0.56	0.64	0.72	0.80	0.88	1.00	1.12	1.20

Note: Airside ΔPs reflects the air pressure drop of the hot water coil

PESV, AESV, DESV / HOT WATER COIL CAPACITY, MBH / 3- AND 4-ROW

Redefine your comfort zone.™ | www.titus-hvac.com

Rows	gpm	Head Loss	Airflow, CFM									
			50	100	150	200	250	300	350	400	450	
Three- Row	2.0	0.70	6.1	10.8	14.4	17.5	20.0	22.3	24.2	25.9	27.4	
	3.0	1.54	6.1	11.0	14.9	18.2	21.0	23.5	25.7	27.6	29.4	
	5.0	4.14	6.2	11.1	15.2	18.8	21.8	24.6	27.0	29.2	31.3	
	6.0	5.90	6.2	11.2	15.3	18.9	22.1	24.9	27.4	29.7	31.8	
	Airside ΔPs		0.01	0.04	0.08	0.12	0.18	0.24	0.31	0.39	0.47	
Four- Row	3.0	1.11	6.5	11.9	16.5	20.5	23.9	26.8	29.5	34.8	34.0	
	4.0	1.95	6.5	12.1	16.8	20.9	24.5	27.7	30.6	33.1	35.5	
	6.0	4.33	6.5	12.2	17.1	21.4	25.2	25.6	31.7	34.5	37.1	
	8.0	5.42	6.5	12.2	17.2	21.6	25.5	29.1	32.3	35.3	38.0	
	Airside ΔPs		0.02	0.05	0.10	0.16	0.24	0.32	0.41	0.52	0.63	
Rows	gpm	Head Loss	Airflow, CFM									
			100	200	300	400	500	600	700	800	900	
Three- Row	2.0	0.50	11.2	18.6	23.8	27.9	31.1	33.7	35.9	37.8	39.4	
	4.0	1.95	11.6	19.8	26.0	31.1	35.3	38.8	41.9	44.7	47.1	
	6.0	4.33	11.7	20.2	26.9	32.3	37.0	41.0	44.5	47.6	50.4	
	8.0	5.42	11.7	20.4	27.3	33.0	37.9	42.1	45.9	49.2	52.2	
Airside ΔPs		0.02	0.08	0.15	0.24	0.35	0.47	0.61	0.77	0.93		
Four- Row	4.0	1.40	12.4	22.1	29.6	35.8	40.9	45.3	49.1	52.4	55.3	
	6.0	3.12	12.5	22.5	30.6	37.3	43.0	48.0	52.4	56.3	59.7	
	8.0	3.53	12.6	22.7	31.1	38.1	44.2	49.5	54.2	58.4	62.2	
	10.0	5.46	12.6	22.9	31.4	38.6	44.9	50.4	55.4	59.8	63.8	
Airside ΔPs		0.03	0.10	0.20	0.32	0.47	0.63	0.82	1.02	1.25		
Rows	gpm	Head Loss	Airflow, CFM									
			200	300	400	500	600	700	800	900	1000	
Three- Row	3.0	0.80	21.0	27.9	33.4	38.0	41.8	45.2	48.1	50.7	52.9	
	5.0	2.19	21.6	29.2	35.5	40.8	45.5	49.6	53.2	56.5	59.4	
	7.0	4.26	21.9	29.8	36.5	42.2	47.2	51.7	55.7	59.4	62.7	
	9.0	4.49	22.1	30.2	37.0	43.0	48.3	53.0	57.3	61.2	64.7	
Airside ΔPs		0.04	0.08	0.13	0.19	0.25	0.33	0.41	0.50	0.59		
Four- Row	4.0	1.16	23.5	32.2	39.4	45.6	50.9	55.5	59.6	63.2	66.5	
	5.0	1.80	23.7	32.7	40.4	46.9	52.6	57.7	62.2	66.2	69.8	
	8.0	2.75	24.1	33.6	41.8	49.0	55.4	61.2	66.4	71.1	75.5	
	10.0	4.25	24.2	33.9	42.3	49.8	56.4	62.4	67.9	72.9	77.5	
Airside ΔPs		0.05	0.11	0.17	0.25	0.34	0.43	0.54	0.66	0.79		
Rows	gpm	Head Loss	Airflow, CFM									
			300	500	700	900	1100	1300	1500	1700	1900	
Three- Row	3.0	0.91	30.3	42.2	50.9	57.6	63.0	67.4	71.1	74.3	77.0	
	4.0	1.61	31.0	44.0	53.8	61.5	67.8	73.1	77.6	81.5	84.9	
	6.0	3.57	31.8	45.9	56.9	65.8	73.3	79.7	85.2	90.1	94.5	
	8.0	4.32	32.2	46.9	58.5	68.2	76.3	83.4	89.6	95.1	100.0	
Airside ΔPs		0.05	0.11	0.19	0.29	0.41	0.54	0.69	0.85	1.02		
Four- Row	4.5	1.63	34.6	50.5	62.9	72.7	80.8	87.6	93.4	98.4	102.8	
	5.0	2.01	34.8	51.1	63.9	74.2	82.7	89.9	96.0	101.4	106.1	
	7.0	2.88	35.1	52.6	66.5	78.0	87.7	96.1	103.4	109.8	115.6	
	9.0	4.11	35.6	53.4	68.0	80.3	90.8	99.9	107.9	115.1	121.5	
Airside ΔPs		0.06	0.15	0.26	0.39	0.55	0.72	0.92	1.13	1.36		

M

PERFORMANCE DATA

PESV, AESV, DESV / HOT WATER COIL CAPACITY, MBH / 3- AND 4-ROW

Sizes 14	Rows	gpm	Head Loss	Airflow, CFM								
				400	700	1000	1300	1600	1900	2200	2500	2800
Three- Row	4.0	1.30	41.3	59.8	73.0	83.0	90.9	97.3	102.7	107.3	111.1	
	5.0	2.01	42.1	61.8	76.3	87.6	96.6	104.1	110.4	115.8	120.5	
	6.0	2.88	42.6	63.2	78.6	90.8	100.7	109.0	116.1	122.2	127.6	
	8.0	3.27	43.3	65.0	81.7	95.2	106.3	115.8	124.0	131.2	137.5	
	Airside ΔPs			0.04	0.10	0.19	0.29	0.41	0.54	0.69	0.86	1.04
Four- Row	6.0	2.06	46.7	71.1	89.5	104.0	115.7	125.5	133.7	140.8	146.9	
	7.0	2.79	47.1	72.2	91.6	107.1	119.8	130.4	139.5	147.4	154.2	
	8.0	2.03	47.4	73.1	93.3	109.5	123.0	134.4	144.1	152.7	160.2	
	10.0	3.15	47.8	74.4	95.6	113.0	127.7	140.2	151.1	160.7	169.2	
	Airside ΔPs			0.05	0.14	0.25	0.38	0.54	0.72	0.93	1.15	1.39
Sizes 16	Rows	gpm	Head Loss	Airflow, CFM								
				600	1000	1400	1800	2200	2600	3000	3400	3800
Three- Row	6.0	1.71	58.5	80.9	97.0	109.3	119.2	127.3	134.0	139.9	144.9	
	8.0	1.51	60.1	84.4	102.5	116.7	128.3	138.0	146.2	153.4	159.6	
	10.0	2.35	61.1	86.7	106.1	121.6	134.4	145.3	154.6	162.7	169.9	
	12.0	3.36	61.8	88.2	108.6	125.1	138.8	150.5	160.7	169.6	177.5	
	Airside ΔPs			0.06	0.14	0.24	0.37	0.51	0.68	0.86	1.06	1.28
Four- Row	9.0	1.58	67.4	97.6	120.6	138.8	153.7	166.2	176.8	185.9	193.9	
	10.0	1.95	67.9	98.8	122.6	141.6	157.3	170.5	181.8	191.6	200.2	
	11.0	2.36	68.3	99.7	124.2	144.0	160.3	174.1	186.0	196.4	205.6	
	12.0	2.80	68.6	100.5	125.6	146.0	162.9	177.3	189.8	200.7	210.3	
	Airside ΔPs			0.08	0.18	0.32	0.49	0.68	0.90	1.15	1.42	1.71
Sizes 24 x 16	Rows	gpm	Head Loss	Airflow, CFM								
				600	1200	1800	2400	3000	3600	4200	4800	5400
Three- Row	6.0	1.86	65.0	103.8	129.6	148.2	162.3	173.5	182.5	190.1	196.5	
	8.0	1.76	66.4	108.6	138.0	160.0	177.3	191.2	202.8	212.6	221.1	
	10.0	2.74	67.2	111.5	143.4	167.9	187.4	203.4	216.9	228.5	238.6	
	12.0	3.92	67.8	113.6	147.2	173.4	194.7	212.3	227.3	240.3	251.6	
	Airside ΔPs			0.03	0.09	0.17	0.27	0.40	0.54	0.70	0.88	1.07
Four- Row	9.0	1.80	72.6	124.0	161.1	189.2	211.2	229.0	243.6	256.0	266.7	
	10.0	2.22	73.0	125.5	164.1	193.6	217.1	236.2	252.1	265.6	277.2	
	11.0	2.68	73.3	126.7	166.5	197.3	222.0	242.3	259.3	273.9	286.4	
	12.0	3.18	73.5	127.7	168.6	200.5	226.3	247.6	265.6	281.1	294.5	
	Airside ΔPs			0.04	0.12	0.23	0.37	0.53	0.72	0.93	1.17	1.42

- All coil performance in accordance with AHRI 410-2001
- Heating capacities are in MBH
- Data based on 180°F entering water and 55°F entering air
- For temperature differentials other than 125°, multiply MBH by correction factors below
- Head loss is in feet of water
- Always supply water to lowest connection pipe to prevent air entrapment
- Air temperature rise = 927 x MBH/cfm
- Water temperature drop = 2.04 x MBH/gpm
- Connection size is ½ OD male solder for 1-row coil sizes 04-08. All other coils have 7/8" OD male solder.
- Coils are not intended for steam applications and are labeled for a maximum water temperature of 200°F
- Coils are tested for leakage at test pressure of 500 psi
- Water volumes less than those shown may result in laminar flow and reduced heating capacity. If possible reduce the number of coil rows to increase water velocity into turbulent range.

Correction Factors for Other Entering Conditions

ΔT	50	60	70	80	90	100	110	125	140	150
Factor	0.40	0.48	0.56	0.64	0.72	0.80	0.88	1.00	1.12	1.20

Note: Airside ΔPs reflects the air pressure drop of the hot water coil

SELECTION AND CAPACITIES

Recommended Coil Selection Data

The table at the right describes the maximum recommended kW capacities and number of stages available for Titus single duct terminals.

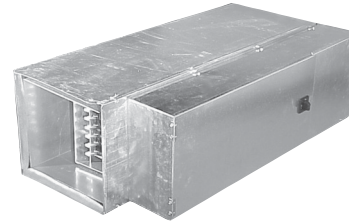

To make a coil selection:

1. Check the desired kW is available in desired unit size and number of stages. (Required to prevent excessive watt density and current draw, while taking into account unit size limitations.)
2. Check the desired minimum airflow limit is within recommended operating range. (Ensures velocity pressure will be sufficient to close airflow sensing switch.)
3. Multiply desired minimum airflow limit by a factor of 0.0142 and check the result is equal to or greater than desired kW. (Limits temperature rise across the coil to 45°F.)

Titus electric heating coils are specifically designed for use with VAV terminal units. They include an extended plenum section and diffuser plate to minimize stratification. The heating elements are designed to minimize hot spots and nuisance tripping of the thermal cutouts.

$$kW \leq cfm \times 0.0142$$

These requirements established to prevent excessive temperature rise caused by low airflow and/or oversized coils. Minimum airflow limits

Must be within recommended ranges to ensure proper operation and long service life. For optimum diffuser performance and maximum thermal comfort, coil discharge temperatures should not be more than 15°F above desired room temperatures. For proper coil operation it is recommended that coil discharge temperatures do not to exceed 100°F.

Note: The Titus 480V, 3-phase electric heat configuration is 4-wire wye. 3-wire configuration is available.

PESV, AESV, DESV / APPLICATION DATA (STAGED HEAT)

Inlet Size	Heating cfm Range	Number of Steps Available	120V 1 Phase kW Range		208V 1 Phase kW Range		240V 1 Phase kW Range		277V 1 Phase kW Range		208V 3 Phase kW Range		480V 3 Phase kW Range	
			Min	Max	Min	Max	Min	Max	Min	Max	Min	Max	Min	Max
4	55-225	1	0.5		0.5		1.0		1.0		1.5		2.5	
		2	1.0	5.0	1.0	3.0	1.5	3.0	1.5	3.0	1.5	3.0	2.5	3.0
		3	1.5		1.5		2.0		2.5		2.5			
5	85-350	1	0.5		0.5		1.0		1.0		1.5		2.5	
		2	1.0	5.0	1.0	5.0	1.5	5.0	1.5	5.0	1.5	5.0	2.5	5.0
		3	1.5		1.5		2.0		2.5		2.5			
6	105-500	1	0.5		0.5		1.0		1.0		1.5		2.5	
		2	1.0	5.0	1.0	7.5	1.5	7.5	1.5	7.5	1.5	7.5	2.5	7.5
		3	1.5		1.5		2.0		2.5		2.5			
7	135-650	1	0.5		0.5		1.0		1.0		1.5		2.5	
		2	1.0	5.0	1.0	9.5	1.5	9.5	1.5	9.5	1.5	9.5	2.5	9.5
		3	1.5		1.5		2.0		2.5		2.5			
8	190-900	1	0.5		0.5		1.0		1.0		1.5		2.5	
		2	1.0	5.0	1.0	9.5	1.5	11.0	1.5	13.0	1.5	13.0	2.5	13.0
		3	1.5		1.5		2.0		2.5		2.5			
9	225-1050	1	0.5		0.5		1.0		1.0		1.5		2.5	
		2	1.0	5.0	1.0	9.5	1.5	11.0	1.5	13.0	1.5	16.0	2.5	16.0
		3	1.5		1.5		2.0		2.5		2.5			
10	300-1400	1	0.5		0.5		1.0		1.0		1.5		2.5	
		2	1.0	5.0	1.0	9.5	1.5	11.0	1.5	13.0	1.5	16.0	2.5	21.0
		3	1.5		1.5		2.0		2.5		2.5			
12	425-2000	1	0.5		0.5		1.0		1.0		1.5		2.5	
		2	1.0	5.0	1.0	9.5	1.5	11.0	1.5	13.0	1.5	16.0	2.5	30.0
		3	1.5		1.5		2.0		2.5		2.5			
14	575-3000	1	0.5		1.0		1.0		1.5		1.5		3.0	
		2	1.0	5.0	2.0	9.5	2.0	11.0	2.0	13.0	2.0	16.0	3.0	36.0
		3	1.5		3.0		3.0		3.0		3.0		3.0	
16	750-4000	1	0.5		1.0		1.0		1.5		1.5		3.0	
		2	1.0	5.0	2.0	9.5	2.0	11.0	2.0	13.0	2.0	16.0	3.0	36.0
		3	1.5		3.0		3.0		3.0		3.0		3.0	
24x16	1800-8000	1	1.0		1.0		1.0		1.5		1.5		3.0	
		2	2.0	5.0	2.0	9.5	2.0	11.0	3.0	13.0	2.0	16.0	4.0	36.0
		3	3.0		3.0		3.0		4.5		3.0			

Useful formulas: $kW = \frac{cfm \times \Delta T}{3160}$ or $\Delta T = \frac{kW \times 3160}{cfm}$ or $cfm = \frac{kW \times 3160}{\Delta T}$

Where ΔT = air temperature rise.

PESV, AESV, DESV / APPLICATION DATA (LYNERGY HEAT)

Inlet Size	Heating cfm Range	120V 1 Phase kW Range		208V 1 Phase kW Range		240V 1 Phase kW Range		277V 1 Phase kW Range		208V 3 Phase kW Range		480V 3 Phase kW Range	
		Min	Max	Min	Max	Min	Max	Min	Max	Min	Max	Min	Max
4	55-225	0.5	2.5	0.5	3.0	1.0	3.0	1.0	3.0	1.5	3.0	2.5	3.0
5	85-350	0.5	4.5	0.5	5.0	1.0	5.0	1.0	5.0	1.5	5.0	2.5	5.0
6	105-500	0.5	5.0	0.5	7.5	1.0	7.5	1.0	7.5	1.5	7.5	2.5	7.5
7	135-650	0.5	5.0	0.5	9.5	1.0	9.5	1.0	9.5	1.5	9.5	2.5	9.5
8	190-900	0.5	5.0	0.5	9.5	1.0	11.0	1.0	13.0	1.5	10.5	2.5	13.0
9	225-1050	0.5	5.0	0.5	9.5	1.0	11.0	1.0	13.0	1.5	10.5	2.5	16.0
10	300-1400	0.5	5.0	0.5	9.5	1.0	11.0	1.0	13.0	1.5	10.5	2.5	21.0
12	425-2000	0.5	5.0	0.5	9.5	1.0	11.0	1.0	13.0	1.5	10.5	2.5	25.0
14	575-3000	0.5	5.0	1.0	9.5	1.0	11.0	1.5	13.0	1.5	10.5	3.0	25.0
16	750-4000	0.5	5.0	1.0	9.5	1.0	11.0	1.5	13.0	1.5	10.5	3.0	25.0
24x16	1800-8000	2.0	5.0	1.0	9.5	1.0	11.0	1.5	13.0	1.5	10.5	4.0	25.0

AHRI Directory Of Certified Performance

Titus is a charter member company and current participant in the AHRI Directory of Certified Performance. This voluntary certification program was developed by participating manufacturers in conjunction with the former Air-Conditioning and Refrigeration Institute (ARI) in the 1990's. It is currently administrated by the Air-Conditioning, Heating, and Refrigeration Institute (AHRI). The purpose of this program is to provide for the independent verification of manufacturers' published performance data. Only participating products are authorized to bear the AHRI VAV Certification Mark. Certified data may be viewed and downloaded at www.ahrinet.org.

In order to participate in this program, member companies pay annual dues based on sales volume, submit published performance data for all applicable model types, and agree to provide a number of randomly selected product samples for annual rounds of independent testing at the manufacturers' expense. All verification testing is conducted in accordance with ASHRAE Standard 130 'Methods of Testing Air Terminal Units'. These tests are conducted to verify that a manufacturer's published certified ratings are within the test tolerances outlined in AHRI Standard 880 'Performance Rating of Air Terminals'. Any failure to demonstrate the certified performance is punished by additional testing requirements, mandatory performance re-rating, monetary penalties and possible expulsion from the Certified Directory.

Product samples provided for certification testing are standard production units with standard 1/2" dual density fiberglass lining (unless otherwise specified) and no optional appurtenances such as add-on attenuators or heating/cooling coils. The certified ratings are measured at the standard operating points under the following test conditions:

PESV, EESV, AESV, DESV

- Rated airflow (cfm) – Based on an inlet velocity of 2000 fpm
- Rated Min ΔPs (in wg) – Minimum static pressure drop from the unit inlet to discharge at rated airflow with damper full open
- Rated ΔPs (in wg) – A static pressure drop of 1.5 in wg from unit inlet to discharge
- Rated sound power by octave band (dB, re 10⁻¹² watts) – Radiated and discharge sound performance conducted in a reverberation room that meets both the broadband and pure tone qualifications of AHRI Standard 220

PESV, AESV, DESV

Inlet Size	Rated CFM	Min ΔPs	Discharge		Radiated Sound Power							Discharge Sound Power						
			H	W	2	3	4	5	6	7	2	3	4	5	6	7		
04	150	0.04	8	12	60	57	46	41	40	37	76	67	60	54	54	49		
05	250	0.03	8	12	62	59	49	42	41	37	77	67	61	56	55	50		
06	400	0.13	8	12	63	61	52	44	42	38	78	72	65	60	57	52		
07	550	0.10	10	12	64	59	53	47	43	34	76	73	64	59	56	51		
08	700	0.02	10	12	65	60	53	47	47	45	79	74	64	58	56	52		
09	900	0.05	12.5	14	64	58	53	47	45	38	79	70	64	59	57	54		
10	1100	0.01	12.5	14	67	62	57	55	54	43	80	72	66	63	60	55		
12	1600	0.01	15	16	66	62	59	53	50	44	80	75	68	64	62	58		
14	2100	0.04	17.5	20	66	62	55	53	50	46	76	69	66	63	63	59		
16	2800	0.03	18	24	66	61	54	50	50	45	77	70	66	64	62	57		
40	5300	0.06	18	38	79	74	72	68	67	64	87	81	77	72	73	69		

TITUS DUAL DUCT TERMINAL - LEADERSHIP IN A RE-EMERGING TECHNOLOGY!

The concern for IAQ has led to renewed interest in the benefits of dual duct systems. Dual duct systems are an ideal vehicle for alternative ventilation strategies and humidity control. Additionally, total filtration of all air delivered to the zone is possible. Titus dual duct terminals provide high performance and value, making them the preferred selection for these applications.

Titus dual duct terminals vary the airflow individually between hot and cold inlets for highly accurate temperature control.

As the ratio of hot and cold air is critical in most applications, pressure independent controls are used with a separate velocity control loop to each inlet.

Titus dual duct terminals are available in three styles. In those instances where no blending of airstreams is required, the EDV without the integral attenuator assembly can be an effective choice.

When blending of hot and cold supply air is needed for accurate temperature control with minimum flow requirements, the EDV or EDC with integral attenuator should be used.

The attenuator reduces discharge sound levels and provides some mixing benefit. An optional mixing baffle is available for use with the attenuator to provide maximum blending of hot and cold airstreams. Less than 1°F temperature variation is provided at the discharge with a 10°F inlet temperature differential!

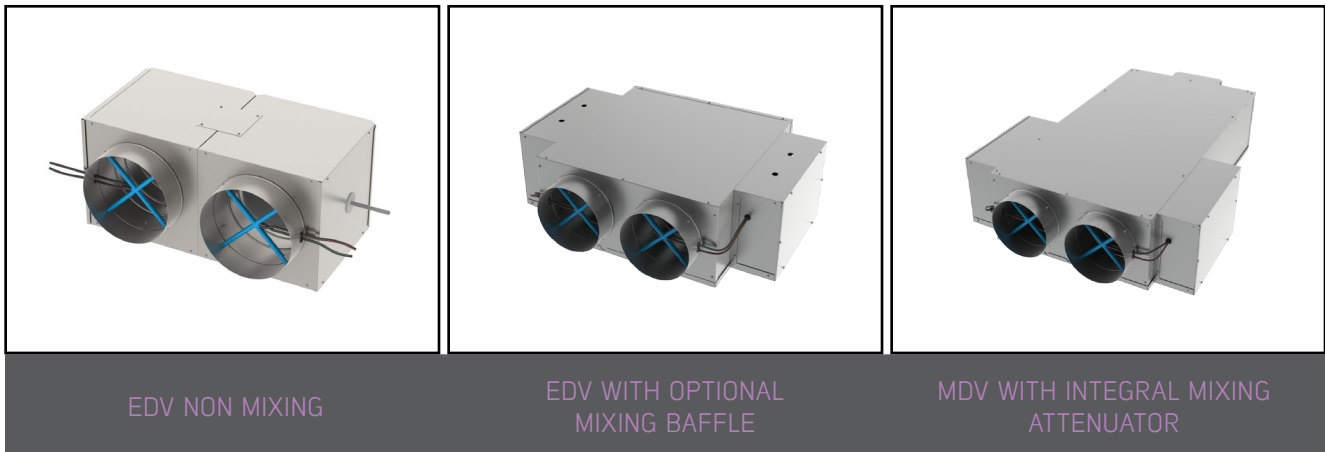

All Titus dual duct terminals are available with Fibre-Free and other lining options.

The Titus MDV/MDC Dual Duct Terminals have been specially designed for those applications where comfort levels are critical, as in hospitals, research facilities, and other institutional applications.

Like the EDV/EDC, the MDV/MDC terminals use separate pressure independent velocity control loops for each inlet, rather than a single velocity controller for discharge volume control only. This provides superior temperature control during blending, as each inlet can compensate for duct pressure changes without affecting the other.

The unique internal mixing baffle design provides for exceptional mixing characteristics. Less than 1°F temperature variation is provided at the discharge with a 20°F inlet temperature differential. Additional ductwork is not required downstream to achieve proper mixing, allowing for immediate take-off to diffusers. This is also beneficial for installations with space limitations.

The tightly sealed casing typically allows less than 1 percent leakage of conditioned air to the space at 1.5 inches wg. differential static pressure, making this one of the most energy efficient dual duct terminals. The dampers are the improved Titus low leakage design.

All Titus dual duct terminals are also available with EcoShield, Fibre Free and SteriLoc lining options. Specify the MDV/MDC and you will be providing the best performing dual duct terminal available.

VAV, Zero Minimum - non-blending

In cooling mode, as temperature approaches setpoint, cold airflow modulates from maximum to zero flow. As room temperature drops below setpoint, hot airflow modulates from zero to maximum. Heating and cooling maximum flow rates can be different. A deadband may be utilized.

As this is a non-blending application, a mixer/attenuator section is not required. For detailed information on specific control types, refer to the following pages in Section O:

Pneumatic: 020 / Digital: 06 / Model: EDV

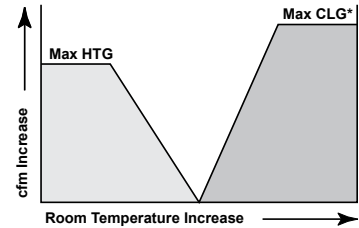

VAV, Minimum Mix Equal to Maximum HTG - blending

In cooling mode, as temperature approaches setpoint, cold air modulates from maximum to a minimum mix flow rate. As temperature continues to drop, hot airflow modulates open as cold airflow closes, maintaining a minimum total flow rate. Lower heating flow rates require unequal inlet sizes to maintain control. A mixer/attenuator section is required.

Pneumatic: 020 / Digital: 06 / Model: EDV or MDV

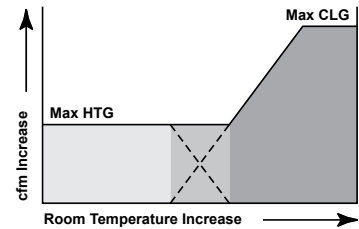

VAV, Minimum Mix, Unequal Maximum Flows - blending

Similar in cooling mode to the sequence above, when entering the heating mode a flow rate higher than the minimum mix is employed. Maximum flow rates may be close enough that equal inlet sizes may be used. A mixer/attenuator section is required.

Pneumatic: 020 / Digital: 06 / Model: EDV or MDV

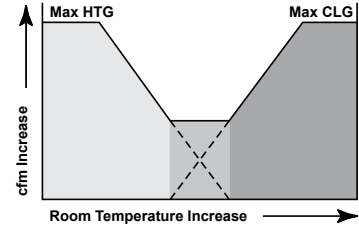

Constant Volume Discharge - blending

In this sequence cooling and heating maximum flow rates are the same and minimum mix flow rates are the same as maximums. The result is a constant airflow over the entire cooling and heating range. A mixer/attenuator section is required.

Pneumatic: 020 / Digital: 06 / Model: EDC or MDC

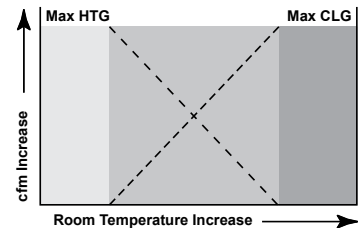

Optional Sensor Location Configuration

For blending applications with integral mixer/attenuator. Multi-point velocity sensors are available in four different configurations to match any application and control requirement. Configurations 3B and 3C are to match hot or cold inlet control requirements.

Pneumatic: 020 / Digital: 06

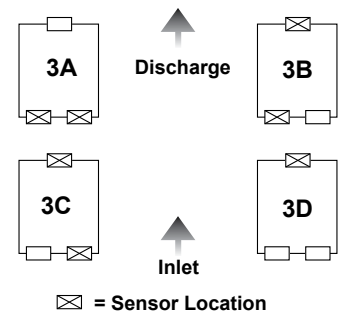

Dual Duct without Attenuator

single / dual duct terminals

EDV / EDV-S

- Standard AeroCross™ multi-point center averaging velocity sensors in each inlet for accurate flow control
- Standard matte faced insulation for maximum thermal and acoustic performance
- Mechanically sealed and gasketed, leak resistant construction
- Choice of right or left hand cold duct location; right hand is standard
- Standard 22 gauge casing with slip and drive discharge connection
- Controls supplied by Titus are factory calibrated for quicker start-up
- OSP & IBC seismic certifications available for EDV-S units with Titus pneumatic, analog, and digital controls

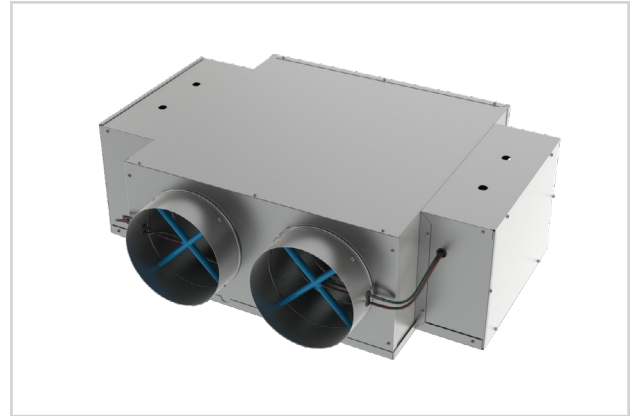

EDV



seismic certified

MODELS:

PEDV / Pneumatic
DEDV / Digital Electronic
EDV-S / Seismic Option

OVERVIEW

For Non-Blending Applications Only

Titus Dual Duct terminals vary the airflow individually between hot and cold inlets for highly accurate temperature control. Dual duct systems are an ideal vehicle for alternative ventilation strategies and humidity control. Additionally, total filtration of all air delivered to the zone is possible. Titus dual duct terminals provide high performance and value, making them the preferred selection for these applications.

ADDITIONAL FEATURES

- Direct digital control package supplied by Titus includes: direct digital controller, damper actuators and flow transducers
- Dual density insulation, coated to prevent air erosion, meet requirements of NFPA 90A and UL 181



See website for Specifications

M

EDV

M27

EDV UNIT DIMENSIONS

PEDV - Basic Unit with Controls

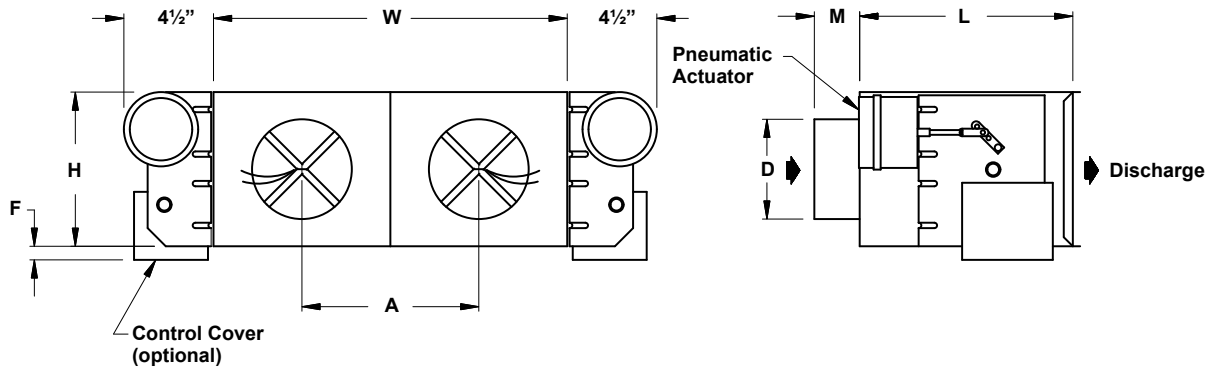

DEDV - Basic Unit with Controls

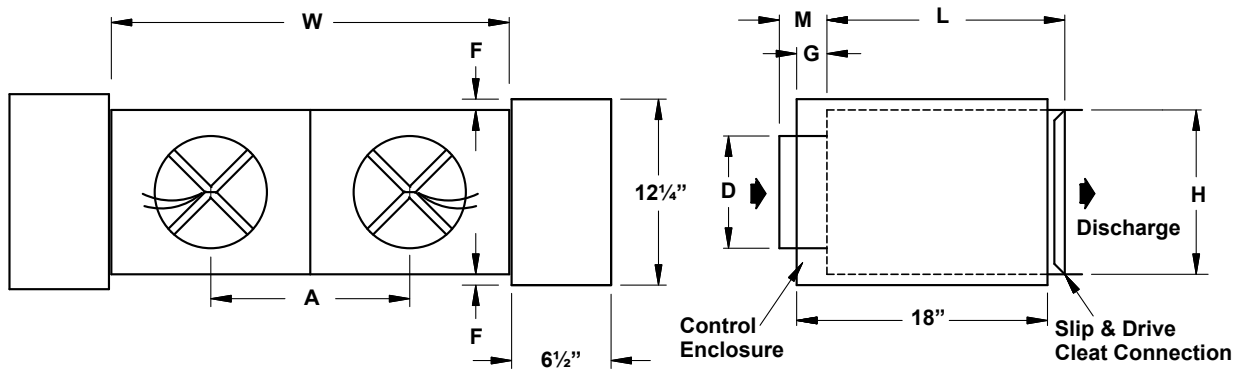

Inlet Size	cfm Range	A	D	F		G	H	L	M	W
				PEDV	DEDV					
4	0-225	12 ¹ / ₈	3 ⁷ / ₈	1 ⁷ / ₈	2 ¹ / ₈	7 ³ / ₈	8	15 ¹ / ₂	5 ³ / ₈	24 ¹ / ₈
5	0-350	12 ¹ / ₈	4 ⁷ / ₈	1 ⁷ / ₈	2 ¹ / ₈	7 ³ / ₈	8	15 ¹ / ₂	5 ³ / ₈	24 ¹ / ₈
6	0-500	12 ¹ / ₈	5 ⁷ / ₈	1 ⁷ / ₈	2 ¹ / ₈	7 ³ / ₈	8	15 ¹ / ₂	3 ³ / ₈	24 ¹ / ₈
7	0-650	12 ¹ / ₈	6 ⁷ / ₈	7 ¹ / ₈	1 ¹ / ₈	7 ³ / ₈	10	15 ¹ / ₂	3 ³ / ₈	24 ¹ / ₈
8	0-900	12 ¹ / ₈	7 ⁷ / ₈	7 ¹ / ₈	1 ¹ / ₈	7 ³ / ₈	10	15 ¹ / ₂	3 ³ / ₈	24 ¹ / ₈
9	0-1050	14 ¹ / ₈	8 ⁷ / ₈	-	-	5 ³ / ₈	12 ¹ / ₂	15 ¹ / ₂	3 ³ / ₈	28 ¹ / ₈
10	0-1400	14 ¹ / ₈	9 ⁷ / ₈	-	-	5 ³ / ₈	12 ¹ / ₂	15 ¹ / ₂	3 ³ / ₈	28 ¹ / ₈
12	0-2000	16 ¹ / ₈	11 ⁷ / ₈	-	-	5 ³ / ₈	15	15 ¹ / ₂	3 ³ / ₈	32 ¹ / ₈
14	0-3000	20 ¹ / ₈	13 ⁷ / ₈	-	-	3 ³ / ₈	17 ¹ / ₂	15 ¹ / ₂	3 ³ / ₈	40 ¹ / ₈
16	0-4000	24 ¹ / ₈	15 ⁷ / ₈	-	-	3 ³ / ₈	18	15 ¹ / ₂	3 ³ / ₈	48 ¹ / ₈

PEDV, DEVV WITHOUT ATTENUATOR - RADIATED SOUND PERFORMANCE

Size	CFM	Min ΔPs	Octave Band Sound Power, Lw																							
			1.0" ΔPs								1.5" ΔPs								2.0" ΔPs							
			2	3	4	5	6	7	NC	2	3	4	5	6	7	NC	2	3	4	5	6	7	NC			
4	100	0.02	52	48	39	36	35	31	15	53	50	41	37	37	34	17	55	51	43	38	39	36	18			
	125	0.03	55	52	42	38	36	32	20	57	54	44	40	39	36	22	58	55	45	41	40	38	23			
	150	0.04	58	55	44	40	38	34	23	60	57	46	41	40	37	25	61	58	47	42	42	39	27			
	175	0.06	61	58	46	42	39	34	27	63	59	48	43	41	38	28	64	61	49	44	43	40	30			
	200	0.08	63	60	47	43	40	35	29	65	62	49	44	42	38	31	66	63	51	45	44	41	33			
5	150	0.01	53	49	41	36	35	30	16	55	51	43	38	37	33	18	57	53	45	39	39	35	21			
	200	0.02	56	53	44	38	37	32	21	59	55	46	40	40	35	23	60	57	48	42	41	37	25			
	250	0.03	59	56	46	40	39	34	24	62	59	49	42	41	37	28	63	61	51	44	43	39	30			
	300	0.04	62	59	48	42	41	35	28	64	61	50	44	43	38	30	65	63	52	45	44	40	33			
	350	0.06	63	61	49	43	42	36	30	66	63	52	45	44	39	33	67	65	54	47	45	41	35			
6	300	0.07	59	54	45	39	37	33	22	61	57	48	41	39	36	25	63	59	50	42	41	38	28			
	350	0.10	60	57	47	41	38	34	25	62	59	50	43	40	37	28	64	62	52	44	42	39	31			
	400	0.13	61	58	49	42	39	35	27	63	61	52	44	42	38	30	65	63	54	46	43	40	33			
	450	0.16	62	60	50	44	40	36	29	64	63	53	46	43	39	33	66	65	55	47	45	41	35			
	500	0.20	63	61	51	45	41	37	30	65	64	54	47	44	40	34	67	67	56	49	46	42	37			
7	450	0.07	61	54	48	42	38	30	23	62	57	51	45	41	33	25	63	59	53	46	43	35	28			
	500	0.09	62	55	49	43	39	30	24	63	58	52	46	42	34	27	64	60	54	48	44	36	29			
	550	0.10	63	57	50	45	40	31	25	64	59	53	47	43	34	28	66	62	55	49	45	37	31			
	600	0.12	63	58	51	46	41	31	27	65	61	54	48	44	35	30	66	63	56	50	46	37	33			
	650	0.15	64	59	52	47	41	32	28	65	62	55	49	44	35	31	66	64	57	51	46	38	34			
8	600	0.02	62	55	49	43	43	39	24	64	58	52	46	45	44	27	65	60	54	47	47	47	29			
	650	0.02	63	56	50	44	44	40	25	65	59	53	47	46	45	28	66	61	55	48	48	48	30			
	700	0.02	63	57	50	45	44	41	25	65	60	53	47	47	45	29	67	62	56	49	49	48	31			
	750	0.02	64	58	51	46	45	41	27	66	61	54	48	48	46	30	67	63	56	50	50	49	33			
	800	0.03	65	59	52	47	46	42	28	66	62	55	49	48	47	31	68	64	57	51	50	50	34			
9	800	0.04	61	53	49	42	40	35	23	62	57	52	46	44	38	26	63	59	55	48	47	40	29			
	850	0.04	61	54	49	43	41	35	23	63	58	53	46	45	38	27	64	60	55	49	47	40	29			
	900	0.05	62	55	50	43	41	35	24	64	58	53	47	45	38	27	65	61	56	49	48	40	30			
	950	0.06	62	56	50	43	42	36	24	64	59	54	47	45	38	28	65	62	56	49	48	40	31			
	1000	0.06	63	56	50	44	42	36	25	65	60	54	47	46	39	29	66	62	57	50	48	40	31			
10	900	0.01	63	57	53	50	48	37	27	65	60	57	53	52	41	31	67	63	59	56	54	44	34			
	1000	0.01	64	58	54	51	49	38	28	66	61	57	54	53	42	31	67	64	59	56	55	45	34			
	1100	0.01	65	58	54	52	50	39	28	67	62	57	55	54	43	31	68	64	60	57	56	46	35			
	1200	0.01	65	59	54	53	51	40	28	67	63	58	56	55	44	33	69	65	60	58	57	47	35			
	1300	0.01	66	60	55	53	52	41	29	68	63	58	56	55	45	33	69	66	61	58	58	48	36			
12	1200	0.01	62	56	52	47	43	37	26	64	59	56	50	46	41	30	66	61	58	53	49	43	32			
	1400	0.01	63	57	54	48	45	39	28	65	60	57	52	48	42	31	67	63	60	54	51	45	35			
	1600	0.01	64	59	55	49	46	40	29	66	62	59	53	50	44	34	68	64	61	55	52	47	36			
	1800	0.01	65	60	56	50	48	41	30	67	63	60	54	51	45	35	69	65	62	56	54	48	37			
	2000	0.01	66	61	57	51	49	43	31	68	64	61	55	52	47	36	69	67	63	57	55	49	38			
14	1500	0.02	60	56	50	48	45	41	24	62	59	53	51	48	45	28	64	61	55	53	50	47	30			
	1800	0.03	62	58	51	49	46	42	27	64	60	54	52	49	45	29	66	63	56	54	51	48	33			
	2100	0.04	63	59	52	50	47	43	28	66	62	55	53	50	46	31	67	64	58	55	52	49	34			
	2400	0.05	64	60	53	51	48	43	29	67	63	56	54	51	47	33	69	65	58	56	53	49	35			
	2700	0.06	66	61	54	52	49	44	30	68	64	57	55	52	47	34	70	66	59	57	54	50	36			
16	2000	0.02	59	53	47	45	44	38	21	61	56	50	47	47	41	24	63	58	52	49	49	44	27			
	2400	0.02	61	56	49	47	46	39	24	64	59	52	49	49	43	28	65	61	54	51	51	46	30			
	2800	0.03	63	58	51	48	47	41	27	66	61	54	50	50	45	30	67	63	55	52	52	48	33			
	3200	0.04	65	60	52	50	49	42	29	67	62	55	52	52	46	31	69	64	57	53	54	49	34			
	3600	0.05	66	61	54	51	50	44	30	69	64	56	53	53	48	34	71	66	58	55	55	50	36			

- Radiated sound is the noise transmitted through the unit casing
- Min ΔPs is the static pressure drop from the unit inlet to the unit outlet with the cold damper full open
- Sound power levels are in dB, ref 10⁻¹² watts
- Sound performance based on units lined with standard dual density fiberglass lining
- All performance based on tests conducted in accordance with ASHRAE 130-2008 and AHRI 880-2011
- All NC levels determined using AHRI 885-2008 Appendix E. See Terminal Unit Engineering Guidelines.
- Dash (-) in space denotes NC value less than NC10
- Only highlighted data points are AHRI certified. Refer to page M38 for AHRI Certified Performance Listings.

PEDV, DEDV WITHOUT ATTENUATOR - DISCHARGE SOUND PERFORMANCE

Size	CFM	Min ΔPs	Octave Band Sound Power, Lw																				
			1.0" ΔPs							1.5" ΔPs							2.0" ΔPs						
			2	3	4	5	6	7	NC	2	3	4	5	6	7	NC	2	3	4	5	6	7	NC
4	100	0.02	68	58	51	46	47	41	25	69	60	54	49	50	46	26	70	61	56	51	53	49	28
	125	0.03	70	62	54	49	49	43	28	71	63	57	52	52	47	29	72	64	59	54	55	51	30
	150	0.04	72	64	57	51	50	44	30	73	66	60	54	54	49	31	73	67	61	56	57	52	31
	175	0.06	73	67	59	53	51	45	31	74	68	62	56	55	50	33	75	70	64	58	58	53	34
	200	0.08	74	69	61	55	53	46	33	75	71	63	58	56	51	34	76	72	65	60	59	54	35
5	150	0.01	67	57	52	47	47	42	24	69	59	55	50	51	46	26	70	61	58	52	53	49	28
	200	0.02	70	60	56	51	49	44	28	72	63	59	53	53	48	30	73	65	61	55	55	51	31
	250	0.03	72	64	58	53	51	45	30	74	66	61	56	55	50	33	75	68	63	58	57	53	34
	300	0.04	74	66	60	55	53	46	29	75	69	63	58	56	51	30	76	71	66	60	59	54	31
	350	0.06	75	68	62	57	54	47	30	77	71	65	60	57	52	33	78	73	67	61	60	55	34
6	300	0.07	69	64	59	54	51	46	23	72	67	62	57	54	50	26	74	69	64	58	56	53	29
	350	0.10	71	66	61	56	52	47	25	73	69	64	59	55	51	28	75	71	66	60	58	54	31
	400	0.13	72	68	62	58	53	48	27	75	71	65	60	57	52	31	76	73	67	62	59	55	33
	450	0.16	73	69	64	59	54	49	28	76	72	67	62	58	53	32	78	75	69	63	60	56	36
	500	0.20	74	71	65	61	55	50	31	77	74	68	63	59	54	34	79	76	70	65	61	57	37
7	450	0.07	72	65	58	54	51	46	26	73	69	60	56	54	49	28	75	71	62	58	56	52	31
	500	0.09	72	67	59	56	52	47	26	74	70	62	58	55	50	30	75	73	63	59	57	53	33
	550	0.10	73	68	60	57	53	48	28	74	72	63	59	56	51	32	76	74	64	60	58	54	34
	600	0.12	73	69	61	58	54	48	28	75	73	63	60	57	52	33	76	75	65	61	59	55	36
	650	0.15	73	71	62	59	55	49	31	75	74	64	61	58	53	34	77	76	66	62	59	55	37
8	600	0.02	74	68	59	55	52	47	29	76	71	61	56	55	51	31	77	74	63	57	57	54	34
	650	0.02	75	69	60	56	53	47	30	76	72	62	57	55	51	32	77	75	64	58	57	54	36
	700	0.02	75	70	60	56	53	48	30	77	73	63	58	56	52	33	78	76	64	59	58	55	37
	750	0.02	75	71	61	57	54	48	30	77	74	63	58	56	52	33	78	77	65	60	58	55	37
	800	0.03	76	72	62	58	54	49	31	77	75	64	59	57	53	34	79	77	66	60	59	56	37
9	800	0.04	74	65	60	57	54	49	26	75	68	62	59	57	53	28	76	70	64	60	59	56	29
	850	0.04	74	66	60	57	54	50	26	76	69	62	59	57	54	29	77	71	64	61	59	56	30
	900	0.05	75	67	61	57	55	50	28	77	69	63	59	57	54	30	78	71	65	61	59	57	31
	950	0.06	76	67	61	58	55	50	29	77	70	63	60	58	54	30	78	72	65	61	60	57	31
	1000	0.06	76	68	61	58	55	50	29	78	71	64	60	58	54	31	79	73	65	62	60	57	33
10	900	0.01	75	66	61	59	55	50	28	76	69	64	61	58	54	29	77	72	66	63	61	57	31
	1000	0.01	76	67	62	60	56	51	29	77	70	65	62	59	55	30	78	73	67	64	61	57	32
	1100	0.01	77	68	63	61	56	51	30	78	71	65	63	60	55	31	79	73	67	65	62	58	33
	1200	0.01	77	69	63	61	57	52	30	79	72	66	64	60	56	33	80	74	68	66	63	59	34
	1300	0.01	78	69	64	62	58	53	31	79	73	67	65	61	56	33	80	75	68	66	63	59	34
12	1200	0.01	74	68	63	59	57	52	26	76	71	65	62	60	56	30	77	73	67	64	62	59	32
	1400	0.01	75	70	65	61	59	53	28	77	73	67	63	61	57	32	78	75	69	65	63	60	34
	1600	0.01	76	71	66	62	59	55	30	78	74	68	64	62	58	33	79	76	70	66	64	61	36
	1800	0.01	77	72	67	63	60	56	31	78	75	70	65	63	59	34	79	77	71	67	65	62	37
	2000	0.01	77	73	68	64	61	56	32	79	76	71	66	64	60	36	80	78	72	68	66	63	38
14	1500	0.02	70	63	61	59	57	53	21	72	67	63	62	62	59	25	74	69	65	65	65	62	27
	1800	0.03	71	65	62	59	58	53	23	73	68	65	63	62	59	26	75	71	67	65	65	63	30
	2100	0.04	72	66	64	60	58	54	24	74	69	66	63	63	59	27	76	72	68	66	66	63	31
	2400	0.05	73	67	65	60	59	54	25	75	70	68	64	63	59	28	76	73	69	66	66	63	32
	2700	0.06	74	68	66	61	59	54	26	76	71	69	64	63	60	30	77	74	70	67	66	63	33
16	2000	0.02	70	63	60	58	56	51	21	72	66	62	61	59	54	24	73	68	63	63	61	57	26
	2400	0.02	72	66	63	60	58	52	24	74	68	64	62	61	56	26	75	70	66	64	62	58	28
	2800	0.03	74	68	65	61	59	54	26	76	70	66	64	62	57	29	77	72	68	66	64	60	31
	3200	0.04	75	69	66	62	60	55	28	77	72	68	65	63	59	31	78	73	70	67	65	61	32
	3600	0.05	76	71	68	63	61	56	30	78	73	70	66	64	60	32	80	75	71	68	66	62	34

- Discharge sound is the noise emitted from the unit discharge into the downstream ductwork
- Min ΔPs is the static pressure drop from the unit inlet to the unit outlet with the cold damper full open
- Sound power levels are in dB, ref 10⁻¹² watts
- Sound performance based on units lined with standard dual density fiberglass lining
- All performance based on tests conducted in accordance with ASHRAE 130-2008 and AHRI 880-2011
- All NC levels determined using AHRI 885-2008 Appendix E. See Terminal Unit Engineering Guidelines.
- Dash (-) in space denotes NC value less than NC10
- Only highlighted data points are AHRI certified. Refer to page M38 for AHRI Certified Performance Listings.

Dual Duct with Attenuator

single / dual duct terminals

EDV / EDC

- Standard AeroCross™ multi-point center averaging velocity sensors in four location combinations to match any control requirement
- Standard matte faced insulation for maximum thermal and acoustic performance
- Mechanically sealed and gasketed, leak resistant construction
- Choice of right or left hand cold duct location; right hand is standard
- Standard 22 gauge casing with slip and drive discharge connection
- Controls supplied by Titus are factory calibrated for quicker start-up

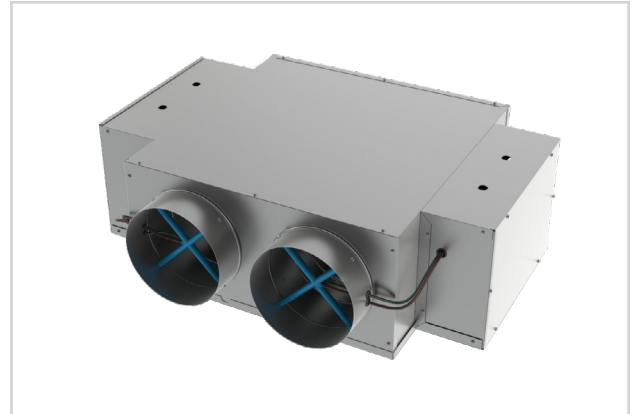

EDV / EDC

MODELS:

PEDV / Pneumatic
PEDC / Pneumatic
DEDV / Digital Electronic



See website for Specifications

OVERVIEW

For Blending or Non-Blending Applications

Titus Dual Duct terminals vary the airflow individually between hot and cold inlets for highly accurate temperature control. Dual duct systems are an ideal vehicle for alternative ventilation strategies and humidity control. Additionally, total filtration of all air delivered to the zone is possible. Titus dual duct terminals provide high performance and value, making them the preferred selection for these applications.

ADDITIONAL FEATURES

- Direct digital control package supplied by Titus includes: direct digital controller, damper actuators and flow transducers
- Dual density insulation, coated to prevent air erosion, meet requirements of NFPA 90A and UL 181

EDV UNIT DIMENSIONS

PEDV - Basic Unit with Controls

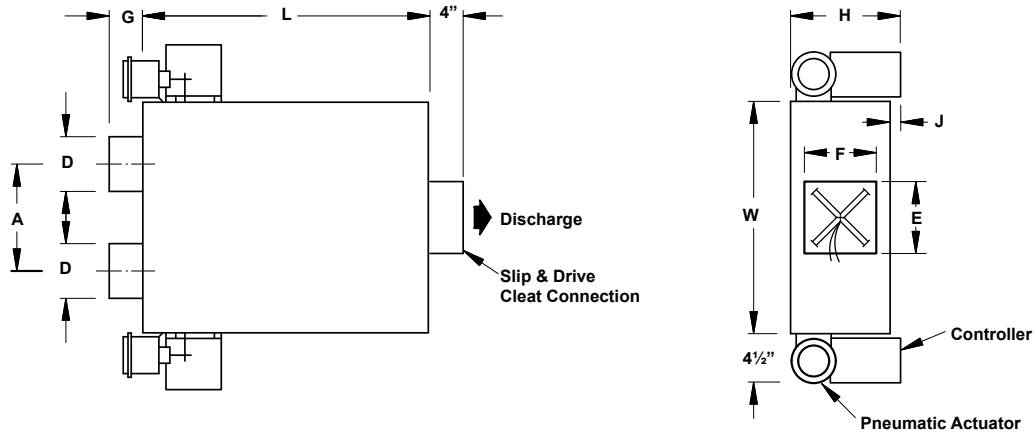

DEDV - Basic Unit with Controls

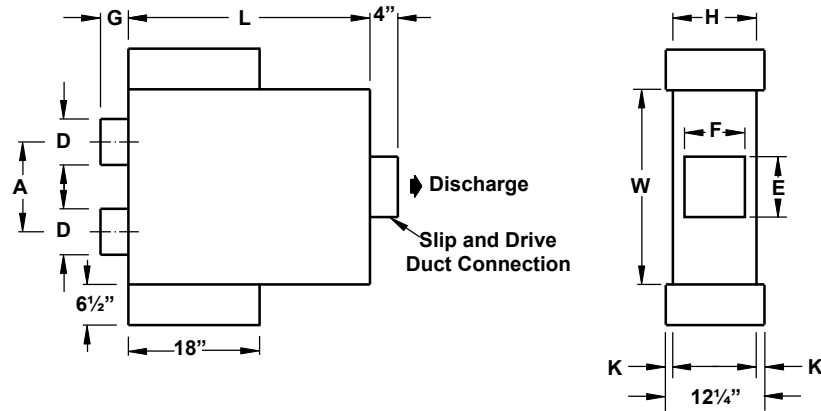

Inlet Size	cfm Range	A	D	E	F	G	H	L	W	PEDV J	DEDV K
4	0-225	8 ⁷ / ₈	3 ⁷ / ₈	5 ¹³ / ₁₆	5 ¹³ / ₁₆	5 ³ / ₈	8 ¹ / ₈	19 ¹ / ₈	19	1 ⁷ / ₈	2
5	0-350	8 ⁷ / ₈	4 ⁷ / ₈	5 ¹³ / ₁₆	5 ¹³ / ₁₆	5 ³ / ₈	8 ¹ / ₈	19 ⁷ / ₈	19	1 ⁷ / ₈	2
6	0-500	8 ⁷ / ₈	5 ⁷ / ₈	5 ¹³ / ₁₆	5 ¹³ / ₁₆	3 ³ / ₈	8 ¹ / ₈	19 ¹ / ₈	19	1 ⁷ / ₈	2
7	0-650	10 ⁷ / ₈	6 ⁷ / ₈	7 ¹ / ₁₆	8 ¹ / ₁₆	6 ³ / ₄	10 ¹ / ₈	23 ³ / ₈	23	7 ⁷ / ₈	1
8	0-900	10 ⁷ / ₈	7 ⁷ / ₈	7 ¹ / ₁₆	8 ¹ / ₁₆	3 ³ / ₈	10 ¹ / ₈	23 ³ / ₈	23	7 ⁷ / ₈	1
9	0-1050	12 ⁷ / ₈	8 ⁷ / ₈	10 ¹ / ₁₆	11 ¹ / ₁₆	6 ³ / ₄	12 ⁵ / ₈	27 ¹ / ₈	27	-	-
10	0-1400	12 ⁷ / ₈	9 ⁷ / ₈	10 ¹ / ₁₆	11 ¹ / ₁₆	3 ³ / ₈	12 ⁵ / ₈	27 ¹ / ₈	27	-	-
12	0-2000	14 ⁷ / ₈	11 ⁷ / ₈	11 ¹ / ₁₆	13 ¹ / ₁₆	3 ³ / ₈	15 ¹ / ₈	31 ¹ / ₈	31	-	-
14	0-3000	16 ⁷ / ₈	13 ⁷ / ₈	12 ⁹ / ₁₆	16 ¹ / ₁₆	3 ³ / ₈	18	35 ¹ / ₈	35	-	-
16	0-4000	18 ⁷ / ₈	15 ⁷ / ₈	15 ¹ / ₁₆	16 ¹ / ₁₆	3 ³ / ₈	18	38 ¹ / ₈	38	-	-

PEDV, PEDC, DEDV WITH INTEGRAL ATTENUATOR AND MIXING BAFFLES / RADIATED SOUND PERFORMANCE

Size	CFM	Min ΔPs	Octave Band Sound Power, Lw																							
			1.0" ΔPs							1.5" ΔPs							2.0" ΔPs									
			2	3	4	5	6	7	NC	2	3	4	5	6	7	NC	2	3	4	5	6	7	NC			
4	100	0.18	46	46	37	31	29	23	12	49	49	39	33	33	28	16	52	51	41	35	35	31	18			
	125	0.29	48	49	40	33	31	25	16	52	52	42	36	35	29	20	54	53	44	38	37	33	21			
	150	0.41	50	51	42	35	33	26	18	54	53	44	38	36	31	21	56	55	46	40	39	34	23			
	175	0.56	52	52	44	37	34	28	20	55	55	46	39	38	32	23	58	57	48	41	40	36	25			
	200	0.73	53	54	45	38	36	29	22	57	57	48	41	39	33	25	59	59	49	43	41	37	28			
5	150	0.17	48	45	38	32	32	25	11	51	48	41	35	35	29	15	53	50	43	36	36	32	17			
	200	0.30	51	48	42	35	35	28	15	54	51	44	37	37	32	18	56	54	46	39	39	35	22			
	250	0.47	53	51	44	37	37	31	18	56	54	47	40	39	35	22	58	56	49	41	41	38	24			
	300	0.67	55	53	47	39	38	33	21	58	56	49	41	41	37	24	60	58	51	43	43	40	27			
	350	0.92	57	54	48	40	40	35	22	60	58	51	43	43	39	27	62	60	53	45	44	42	29			
6	300	0.51	51	51	43	38	36	30	18	54	54	46	40	39	34	22	57	57	48	42	41	37	25			
	350	0.70	52	53	44	39	37	31	21	55	56	47	42	40	35	24	57	58	50	44	42	39	27			
	400	0.91	52	54	46	41	38	32	22	55	57	49	43	41	37	25	57	60	51	45	44	40	29			
	450	1.15	NA	NA	NA	NA	NA	NA	NA	NA	55	58	50	45	42	38	27	57	61	52	47	45	31			
	500	1.42	NA	NA	NA	NA	NA	NA	NA	NA	55	60	51	46	43	39	29	58	62	53	48	45	31			
7	450	0.35	59	52	46	41	40	35	20	61	56	49	43	43	40	24	63	58	51	45	45	43	27			
	500	0.44	60	53	47	42	41	36	22	62	57	50	44	44	41	25	64	59	52	46	46	44	28			
	550	0.53	61	54	48	43	41	37	23	63	57	51	45	45	41	25	65	60	53	47	47	45	29			
	600	0.63	62	55	49	43	42	37	24	64	58	52	46	45	42	27	65	61	54	48	48	45	30			
	650	0.74	62	56	49	44	43	38	24	65	59	52	47	46	43	28	66	61	55	48	48	46	30			
8	600	0.40	58	52	45	39	37	35	20	60	57	49	42	40	39	25	62	60	51	44	42	42	29			
	650	0.47	58	53	46	39	38	36	21	61	58	49	42	41	40	27	63	61	52	44	43	43	30			
	700	0.55	59	54	46	40	38	36	22	61	59	50	43	41	40	28	63	62	53	45	43	43	31			
	750	0.63	59	55	47	41	39	37	23	62	60	51	44	41	41	29	64	63	53	46	43	44	33			
	800	0.71	60	56	47	41	39	38	24	62	60	51	44	42	42	29	64	64	54	46	44	44	34			
9	800	0.18	62	53	45	41	42	40	24	64	56	49	44	45	45	27	66	59	52	47	48	48	29			
	850	0.21	63	53	45	42	42	40	25	65	57	49	45	46	45	28	66	59	52	47	48	48	29			
	900	0.23	63	54	46	42	42	40	25	66	57	50	45	46	45	29	67	60	52	47	48	48	31			
	950	0.26	64	54	46	42	43	40	27	66	58	50	46	46	45	29	68	61	53	48	49	49	32			
	1000	0.29	65	55	46	43	43	41	28	67	58	50	46	46	45	31	68	61	53	48	49	49	32			
10	900	0.25	60	52	44	40	38	37	22	63	55	47	42	41	39	25	65	58	49	44	42	41	28			
	1000	0.31	60	52	45	41	39	37	22	63	56	48	43	41	40	25	66	59	50	44	43	42	29			
	1100	0.38	61	53	46	41	40	38	23	64	57	49	43	42	41	27	66	60	51	45	44	43	29			
	1200	0.45	61	54	47	42	40	39	23	64	58	49	44	42	42	27	66	61	51	46	44	44	30			
	1300	0.53	61	55	47	42	40	39	23	65	59	50	45	43	42	28	67	61	52	46	44	44	31			
12	1200	0.25	64	56	52	50	53	52	27	68	59	55	54	57	57	32	70	62	58	57	60	61	34			
	1400	0.33	65	57	54	51	53	52	28	68	61	57	55	58	57	32	70	63	59	58	61	61	34			
	1600	0.44	65	58	55	52	54	52	29	68	62	58	55	58	57	32	71	64	60	58	61	61	36			
	1800	0.55	66	59	56	52	54	52	30	69	63	59	56	58	57	34	71	65	61	59	61	61	36			
	2000	0.68	66	60	57	53	54	52	31	69	64	60	56	58	58	35	72	66	62	59	62	61	37			
14	1500	0.18	62	54	47	42	43	43	24	66	57	50	44	46	47	29	68	60	52	46	47	49	32			
	1800	0.25	63	56	49	43	44	44	25	67	59	52	46	47	48	31	69	61	54	47	49	50	33			
	2100	0.34	64	57	51	45	45	45	27	67	60	53	47	48	49	31	70	63	55	49	49	51	34			
	2400	0.45	65	58	52	46	46	46	28	68	62	55	48	49	49	32	70	64	57	50	50	52	34			
	2700	0.57	65	60	53	47	47	47	29	69	63	56	49	49	50	33	71	65	58	51	51	53	36			
16	2000	0.21	65	55	50	45	47	47	28	68	59	52	47	50	51	32	70	61	53	49	51	53	34			
	2400	0.30	66	57	52	46	48	47	29	69	60	54	48	50	51	33	71	62	56	50	52	53	36			
	2800	0.40	66	58	54	47	48	47	29	70	61	56	50	51	51	34	72	64	58	51	53	53	37			
	3200	0.53	67	59	56	48	49	47	31	70	62	58	51	51	51	34	73	65	59	52	53	53	38			
	3600	0.67	68	60	57	49	49	47	32	71	63	59	51	52	51	36	73	66	61	53	54	53	38			

- Radiated sound is the noise transmitted through the unit casing
- Min ΔPs is the static pressure drop from the unit inlet to the unit outlet with the cold damper full open
- Sound power levels are in dB, ref 10⁻¹² watts
- Sound performance based on units lined with standard dual density fiberglass lining

- All performance based on tests conducted in accordance with ASHRAE 130-2008 and AHRI 880-2011
- All NC levels determined using AHRI 885-2008 Appendix E. See Terminal Unit Engineering Guidelines.
- Dash (-) in space denotes NC value less than NC10
- Only highlighted data points are AHRI certified. Refer to page M38 for AHRI Certified Performance Listings.

PEDV, PEDC, DEDV WITH INTEGRAL ATTENUATOR AND MIXING BAFFLES / DISCHARGE SOUND PERFORMANCE

Size	CFM	Min ΔPs	Octave Band Sound Power, Lw																							
			1.0" ΔPs							1.5" ΔPs							2.0" ΔPs									
			2	3	4	5	6	7	NC	2	3	4	5	6	7	NC	2	3	4	5	6	7	NC			
4	100	0.18	67	58	50	45	44	36	24	68	59	51	46	45	38	25	69	60	52	47	46	39	26			
	125	0.29	70	61	53	48	47	40	28	71	62	54	49	48	41	29	72	63	55	50	49	43	30			
	150	0.41	72	64	56	50	49	43	30	74	65	57	51	50	45	33	75	66	58	52	52	46	34			
	175	0.56	74	66	58	52	51	46	33	76	67	59	53	52	47	35	77	68	60	54	54	49	36			
	200	0.73	76	68	60	54	53	48	35	78	69	61	55	54	50	38	79	70	62	56	55	51	39			
5	150	0.17	65	57	49	44	45	40	21	67	59	52	46	48	43	24	68	61	53	48	49	45	25			
	200	0.30	69	61	53	48	48	44	26	71	63	56	50	50	47	29	72	65	57	51	52	49	30			
	250	0.47	72	64	56	50	50	47	30	74	67	59	52	53	50	33	75	68	60	54	54	52	34			
	300	0.67	74	67	59	52	52	50	29	76	69	61	54	54	53	31	77	71	63	56	56	55	33			
	350	0.92	76	69	61	54	54	52	31	78	71	63	56	56	55	34	79	73	65	57	58	57	35			
6	300	0.51	68	62	54	50	50	48	21	71	65	57	52	53	51	25	73	67	59	53	55	54	28			
	350	0.70	69	63	56	51	52	49	22	72	66	59	53	54	53	26	75	68	61	55	56	55	30			
	400	0.91	70	64	58	53	53	51	24	73	67	60	55	55	54	28	76	70	63	56	57	56	31			
	450	1.15	N/A	N/A	N/A	N/A	N/A	N/A	N/A	74	68	62	56	56	55	29	76	71	64	57	58	58	31			
	500	1.42	N/A	N/A	N/A	N/A	N/A	N/A	N/A	75	69	63	57	57	56	30	77	72	65	58	59	59	33			
7	450	0.35	69	65	55	50	51	48	24	71	67	58	53	54	51	26	73	69	60	54	56	54	28			
	500	0.44	71	66	57	51	52	49	25	73	68	59	54	55	53	28	74	70	61	55	57	55	30			
	550	0.53	72	67	58	52	53	50	26	74	69	60	54	56	54	29	75	71	62	56	57	56	31			
	600	0.63	73	68	59	53	54	52	28	75	71	61	55	56	55	31	76	72	63	57	58	58	32			
	650	0.74	74	69	60	54	55	53	29	76	72	62	56	57	56	32	77	73	64	58	59	59	33			
8	600	0.40	70	66	57	52	53	51	25	72	69	59	54	55	54	28	74	72	61	56	57	57	32			
	650	0.47	71	67	57	53	54	52	26	73	70	60	55	56	55	30	74	72	62	57	58	57	32			
	700	0.55	71	68	58	54	54	52	27	73	71	61	56	57	56	31	75	73	63	57	58	58	33			
	750	0.63	72	68	59	54	55	53	26	74	72	62	56	57	57	31	76	74	64	58	59	59	33			
	800	0.71	72	69	59	55	55	54	27	74	72	62	57	58	57	31	76	75	64	59	59	60	34			
9	800	0.18	74	64	55	52	54	52	26	77	67	58	55	57	56	30	79	70	61	57	59	58	33			
	850	0.21	75	64	55	52	55	52	28	77	68	59	55	57	56	30	79	70	62	57	59	59	33			
	900	0.23	75	65	56	52	55	53	28	78	68	59	55	58	57	31	80	71	62	57	59	60	34			
	950	0.26	76	65	56	53	55	54	29	79	69	60	56	58	57	33	81	71	62	58	60	60	35			
	1000	0.29	77	66	57	53	56	54	30	79	69	60	56	58	58	33	81	72	63	58	60	61	35			
10	900	0.25	74	63	55	52	56	55	26	77	67	59	55	58	59	30	79	70	62	58	60	61	33			
	1000	0.31	75	64	56	53	56	56	28	78	68	60	56	59	60	31	80	71	63	58	60	62	34			
	1100	0.38	76	65	57	53	57	57	29	79	69	61	57	59	61	33	81	72	63	59	61	63	35			
	1200	0.45	76	66	57	54	57	58	29	80	70	61	57	60	62	34	82	73	64	59	61	64	36			
	1300	0.53	77	67	58	54	57	59	30	80	71	62	57	60	62	34	83	73	64	60	62	65	38			
12	1200	0.25	73	64	56	53	56	55	25	76	68	59	56	58	58	29	79	70	62	58	60	61	33			
	1400	0.33	74	65	58	54	57	57	26	78	69	61	57	59	60	31	80	72	63	59	61	62	34			
	1600	0.44	76	67	59	55	58	58	29	79	70	62	58	60	61	33	81	73	65	60	62	64	35			
	1800	0.55	77	68	61	56	59	59	30	80	71	64	59	61	62	34	82	74	66	61	63	65	36			
	2000	0.68	77	69	62	57	60	60	30	81	72	65	60	62	63	35	83	75	67	62	63	66	38			
14	1500	0.18	71	62	55	53	56	56	22	75	66	59	56	58	59	28	77	69	61	58	60	62	30			
	1800	0.25	73	64	57	54	57	58	25	76	68	61	57	60	61	29	79	70	63	59	61	63	33			
	2100	0.34	75	65	59	55	58	59	28	78	69	62	58	61	62	31	80	72	65	60	62	65	34			
	2400	0.45	76	66	60	56	59	61	29	79	70	63	59	62	64	33	82	73	66	61	63	66	36			
	2700	0.57	77	67	61	57	60	62	30	80	71	65	60	62	65	34	83	74	67	62	64	67	38			
16	2000	0.21	73	62	55	53	58	58	25	76	66	58	56	60	61	29	79	69	60	58	62	64	33			
	2400	0.30	74	64	57	55	59	60	26	78	68	60	58	61	63	31	80	71	63	60	63	65	34			
	2800	0.40	75	66	59	56	60	61	28	79	69	62	59	62	64	33	82	72	64	61	64	67	36			
	3200	0.53	76	67	61	58	61	62	29	80	71	64	60	63	66	34	83	73	66	62	65	68	38			
	3600	0.67	77	68	62	59	61	63	30	81	72	65	61	64	67	35	84	75	67	63	65	69	39			

- Discharge sound is the noise emitted from the unit discharge into the downstream ductwork
- Min ΔPs is the static pressure drop from the unit inlet to the unit outlet with the cold damper full open
- Sound power levels are in dB, ref 10⁻¹² watts
- Sound performance based on units lined with standard dual density fiberglass lining
- All performance based on tests conducted in accordance with ASHRAE 130-2008 and AHRI 880-2011
- All NC levels determined using AHRI 885-2008 Appendix E. See Terminal Unit Engineering Guidelines.
- Dash (-) in space denotes NC value less than NC10
- Only highlighted data points are AHRI certified. Refer to page M38 for AHRI Certified Performance Listings

MDV / MDC

- Standard AeroCross™ multi-point center averaging velocity sensors in multiple location combinations to match any control requirement
- Standard matte faced insulation for maximum thermal and acoustic performance
- Mechanically sealed and gasketed, leak resistant construction
- High performance mixing section
- Choice of right or left hand cold duct location; right hand is standard
- Standard 22 gauge casing with slip and drive discharge connection
- Controls supplied by Titus are factory calibrated for quicker start-up

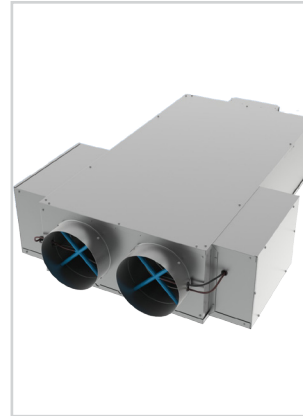

MDV

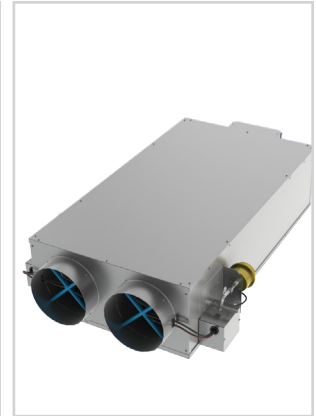

MDC

MODELS:

PMDV / Pneumatic
PMDC / Pneumatic
DMDV / Digital Electronic

OVERVIEW

Titus Dual Duct terminals vary the airflow individually between hot and cold inlets for highly accurate temperature control. Dual duct systems are an ideal vehicle for alternative ventilation strategies and humidity control. Additionally, total filtration of all air delivered to the zone is possible. Titus dual duct terminals provide high performance and value, making them the preferred selection for these applications.

ADDITIONAL FEATURES

- Direct digital control package supplied by Titus includes: direct digital controller, damper actuators and flow transducers
- Dual density insulation, coated to prevent air erosion, meet requirements of NFPA 90A and UL 181



See website for Specifications

MDV / MDC UNIT DIMENSIONS

PMDV/PMDC - Basic Unit with Controls

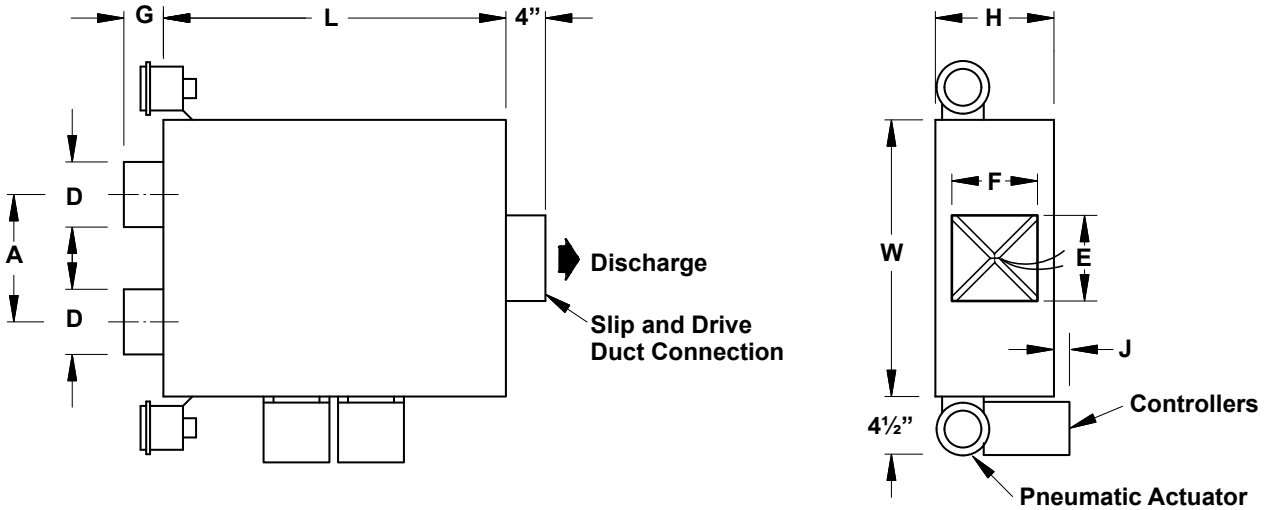

DMDV - Basic Unit with Controls

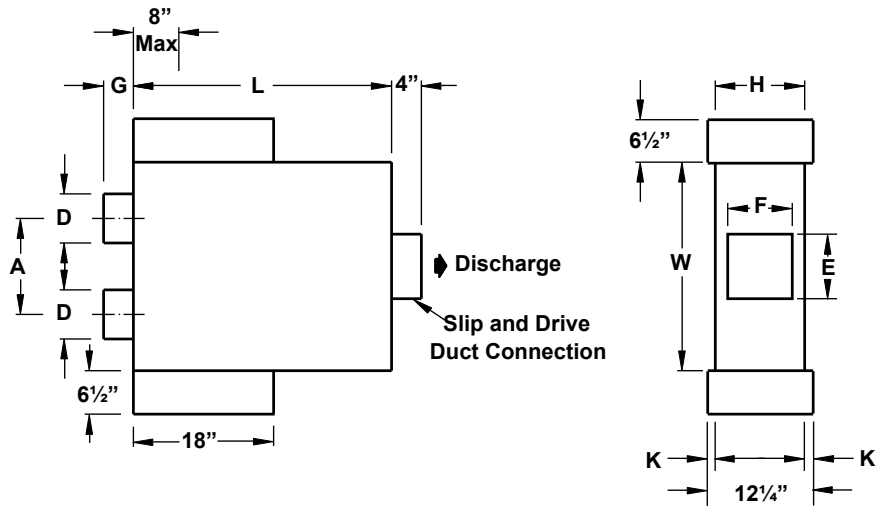

Inlet Size	cfm Range	A	D	E	F	G	H	L	W	PMDV J	DMDV K
4	0-225	8 ⁷ / ₈	3 ⁷ / ₈	5 ⁷ / ₈	5 ⁷ / ₈	5 ³ / ₈	8 ¹ / ₄	34	19	1 ⁷ / ₈	2
5	0-350	8 ⁷ / ₈	4 ⁷ / ₈	5 ⁷ / ₈	5 ⁷ / ₈	5 ³ / ₈	8 ¹ / ₄	34	19	1 ⁷ / ₈	2
6	0-500	8 ⁷ / ₈	5 ⁷ / ₈	5 ⁷ / ₈	5 ⁷ / ₈	3 ³ / ₈	8 ¹ / ₄	34	19	1 ⁷ / ₈	2
7	0-650	10 ⁷ / ₈	6 ⁷ / ₈	7 ¹ / ₈	8 ¹ / ₈	6 ³ / ₄	10 ¹ / ₄	42	23	7 ⁷ / ₈	1
8	0-900	10 ⁷ / ₈	7 ⁷ / ₈	7 ¹ / ₈	8 ¹ / ₈	3 ³ / ₈	10 ¹ / ₄	42	23	7 ⁷ / ₈	1
9	0-1050	12 ⁷ / ₈	8 ⁷ / ₈	10 ¹ / ₈	11 ¹ / ₈	6 ³ / ₄	12 ³ / ₄	50	27	-	-
10	0-1400	12 ⁷ / ₈	9 ⁷ / ₈	10 ¹ / ₈	11 ¹ / ₈	3 ³ / ₈	12 ³ / ₄	50	27	-	-
12	0-2000	14 ⁷ / ₈	11 ⁷ / ₈	11 ¹ / ₈	13 ¹ / ₈	3 ³ / ₈	15 ¹ / ₄	58	31	-	-
14	0-3000	16 ⁷ / ₈	13 ⁷ / ₈	12 ¹ / ₂	16 ¹ / ₈	3 ³ / ₈	18 ¹ / ₈	66	35	-	-
16	0-4000	18 ⁷ / ₈	15 ⁷ / ₈	15 ¹ / ₈	16 ¹ / ₈	3 ³ / ₈	18 ¹ / ₈	72	38	-	-

PMDV, PMDC, DMDV / RADIATED SOUND PERFORMANCE

Size	CFM	Min ΔPs	Octave Band Sound Power, Lw																											
			1.0" ΔPs								1.5" ΔPs								2.0" ΔPs											
			2	3	4	5	6	7	NC	2	3	4	5	6	7	NC	2	3	4	5	6	7	NC							
4	100	0.18	55	50	42	36	35	31	17	57	53	45	38	37	34	21	58	55	47	40	39	36	23	60	57	49	41	40	37	25
	125	0.29	56	52	43	38	36	32	20	58	55	46	40	38	35	23	60	57	49	41	40	37	25	61	58	50	42	41	38	27
	150	0.41	57	53	44	39	37	33	21	59	56	47	41	39	36	24	61	58	50	42	41	38	27	62	60	50	43	41	39	29
	175	0.56	58	55	45	39	38	34	23	60	58	48	42	40	36	27	62	60	50	43	41	39	29	62	60	50	43	41	39	29
	200	0.74	59	56	46	40	38	34	24	61	59	49	42	41	37	28	62	61	51	44	42	39	30	62	61	51	44	42	39	30
5	150	0.15	55	51	43	34	29	21	18	58	55	47	37	32	24	23	59	57	50	42	38	33	28	62	59	52	42	38	33	28
	200	0.27	58	54	45	37	34	27	22	60	57	49	40	36	30	25	62	59	52	42	38	33	28	64	61	53	45	41	38	30
	250	0.42	60	55	46	39	37	32	23	63	59	50	43	40	35	28	64	60	52	45	42	40	29	66	63	55	47	44	42	33
	300	0.60	62	57	48	41	40	36	25	64	60	52	45	42	40	31	67	62	53	46	45	43	29	67	64	56	48	47	45	34
	350	0.82	63	58	49	43	42	40	27	66	62	53	46	45	43	32	68	64	55	48	47	45	31	69	66	58	50	49	47	35
6	300	0.43	58	54	46	41	41	37	22	61	58	50	44	45	41	27	64	61	52	47	47	44	30	67	64	56	48	47	45	34
	350	0.58	59	54	47	42	42	38	22	66	62	53	46	45	43	31	67	64	56	48	47	45	34	69	66	58	50	49	47	35
	400	0.76	60	55	48	44	43	38	23	63	59	51	47	47	43	28	65	62	54	49	50	46	31	69	66	58	50	49	47	35
	450	0.96	60	56	48	45	44	39	24	64	60	52	48	48	43	29	66	63	55	50	51	46	33	70	67	60	52	51	48	37
	500	0.39	63	57	48	43	41	36	25	64	60	53	49	49	44	29	67	63	56	51	52	47	33	70	67	60	52	51	48	37
7	450	0.32	62	56	48	42	40	36	24	64	60	51	45	44	41	29	66	62	54	47	47	45	31	69	66	58	50	49	47	35
	500	0.39	63	57	48	43	41	36	25	65	61	52	46	45	42	30	67	63	56	51	52	47	33	70	67	60	52	51	48	37
	550	0.47	64	58	49	43	41	37	27	66	61	53	46	45	42	30	68	64	55	48	48	46	34	71	68	60	52	51	48	37
	600	0.56	64	58	49	44	42	37	27	67	62	53	47	46	42	31	69	64	56	49	49	46	34	71	68	60	52	51	48	37
	650	0.66	65	59	50	45	42	37	28	68	62	54	48	46	43	32	70	65	56	50	49	46	35	72	69	61	53	52	49	38
8	600	0.37	62	56	48	42	40	38	24	65	61	52	45	44	43	30	68	63	55	47	47	46	33	71	68	60	52	51	48	37
	650	0.43	63	57	49	43	41	39	25	66	61	53	46	45	43	30	68	64	56	48	47	47	34	72	69	61	53	52	49	38
	700	0.50	63	57	50	44	41	39	25	67	61	53	47	45	44	31	69	64	56	49	48	47	34	72	69	61	53	52	49	38
	750	0.57	64	58	50	45	42	40	27	67	62	54	48	46	44	31	69	65	57	50	49	48	35	72	69	61	53	52	49	38
	800	0.65	64	58	50	45	43	40	27	68	62	54	48	47	45	32	70	65	57	50	49	48	35	73	70	62	54	53	50	40
9	800	0.20	67	57	47	40	38	29	31	70	61	51	43	41	34	34	72	64	54	46	43	37	37	73	65	55	47	45	38	38
	850	0.22	67	58	48	41	39	30	31	70	62	52	44	42	34	34	72	65	54	46	44	38	37	73	65	55	47	45	38	38
	900	0.25	68	58	48	42	40	30	32	71	62	52	45	42	35	36	73	65	55	48	45	39	38	73	65	55	48	45	39	38
	950	0.28	68	58	49	42	40	31	32	71	62	52	46	43	35	36	73	66	55	48	45	39	38	73	66	56	49	46	39	38
	1000	0.31	68	59	49	43	41	31	32	71	63	53	46	44	36	36	73	66	56	49	46	39	38	73	66	56	49	46	39	38
10	900	0.21	63	58	51	47	47	47	27	68	63	54	50	51	51	33	71	66	57	52	54	54	36	74	68	60	52	51	48	37
	1000	0.26	64	59	52	48	48	47	28	69	63	55	51	52	51	33	72	66	57	53	54	54	37	74	68	60	52	51	48	37
	1100	0.31	65	59	53	48	49	48	28	69	64	56	51	52	52	34	73	67	58	53	55	55	38	75	68	61	53	52	49	38
	1200	0.37	65	60	53	49	49	48	29	70	65	56	52	53	52	35	73	68	59	54	55	55	38	75	68	61	53	52	49	38
	1300	0.44	66	61	54	49	49	48	30	70	65	57	52	53	53	35	74	68	59	54	56	55	40	76	69	62	54	53	51	40
12	1200	0.29	68	60	54	53	54	52	32	71	63	58	57	58	57	36	74	66	60	60	61	60	40	76	67	61	61	62	61	41
	1400	0.39	69	61	55	54	55	52	33	72	65	59	58	59	58	37	75	67	61	61	62	61	41	76	68	62	61	63	62	42
	1600	0.51	70	62	57	54	56	53	34	73	66	60	58	60	58	38	76	68	62	61	63	62	42	77	69	63	62	64	62	43
	1800	0.64	70	63	58	55	57	54	34	74	67	61	59	61	59	40	77	69	63	62	64	62	43	78	70	64	63	65	63	45
	2000	0.80	71	64	58	56	57	54	36	75	67	62	60	62	59	41	78	70	64	63	65	63	45	78	70	64	63	65	63	45
14	1500	0.16	66	58	49	41	38	31	29	70	62	52	43	40	35	34	73	65	54	45	42	37	38	74	66	56	48	45	40	40
	1800	0.23	67	60	52	43	41	34	31	71	64	54	46	43	37	36	74	66	56	48	45	40	40	75	68	60	52	49	46	45
	2100	0.31	68	61	54	45	43	36	32	72	65	56	48	46	40	37	75	68	58	50	47	42	41	75	68	60	52	50	44	42
	2400	0.41	69	62	56	47	45	38	33	73	66	58	50	48	42	38	76	69	60	52	50	44	42	76	69	60	52	50	44	42
	2700	0.52	70	63	57	49	47	40	34	74	67	60	51	50	44	40	77	69	62	53	51	46	43	77	69	62	53	51	46	43
16	2000	0.20	70	60	53	45	42	37	34	74	64	56	48	44	41	40	77	67	58	50	46	43	43	78	68	60	52	49	46	45
	2400	0.28	71	61	55	47	44	40	36	75	65	58	50	47	43	41	78	68	60	52	49	46	45	79	69	62	54	51	48	46
	2800	0.39	72	62	57	50	47	42	37	76	66	60	52	49	45	42	79	69	62	54	51	48	46	80	70	64	56	53	50	47
	3200	0.50	73	63	59	51	49	44	38	77	68	62	54	51	47	43	80	70	64	56	53	50	47	80	70	64	56	53	50	47
	3600	0.64	74	64	61	53	51	45	40	78	68	64	56	53	49	45	80	71	66	58	55	51	47	80	71	66	58	55	51	47

- Radiated sound is the noise transmitted through the unit casing
- Min ΔPs is the static pressure drop from the unit inlet to the unit outlet with the cold damper full open
- Sound power levels are in dB, ref 10⁻¹² watts
- Sound performance based on units lined with standard dual density fiberglass lining
- All performance based on tests conducted in accordance with ASHRAE 130-2008 and AHRI 880-2011
- All NC levels determined using AHRI 885-2008 Appendix E. See Terminal Unit Engineering Guidelines.
- Dash (-) in space denotes NC value less than NC10
- Only highlighted data points are AHRI certified. Refer to page M38 for AHRI Certified Performance Listings.

PMDV, PMDC, DMDV / DISCHARGE SOUND PERFORMANCE

Size	CFM	Min ΔPs	Octave Band Sound Power, Lw																							
			1.0" ΔPs							1.5" ΔPs							2.0" ΔPs									
			2	3	4	5	6	7	NC	2	3	4	5	6	7	NC	2	3	4	5	6	7	NC			
4	100	0.18	65	57	50	45	38	28	21	67	59	52	47	40	30	24	68	60	54	49	42	32	25			
	125	0.29	68	60	52	47	42	34	25	70	62	55	50	44	36	28	71	63	57	52	45	37	29			
	150	0.41	71	63	55	49	45	38	29	73	65	57	52	47	40	31	74	66	59	54	49	42	33			
	175	0.56	73	65	56	51	48	42	31	75	67	59	54	50	44	34	76	68	61	56	51	46	35			
200	0.74	75	67	58	53	50	46	34	77	69	60	55	52	47	36	78	70	62	57	54	49	38				
5	150	0.15	68	59	52	46	38	31	25	69	61	54	48	40	33	26	71	62	56	50	42	34	29			
	200	0.27	72	63	55	49	44	39	30	73	65	58	52	46	40	31	75	67	60	54	47	41	34			
	250	0.42	75	67	58	52	48	45	34	76	69	61	55	50	46	35	78	70	62	57	51	47	38			
	300	0.60	77	69	60	54	51	50	33	79	71	63	57	53	51	35	80	73	65	59	55	52	36			
350	0.82	79	72	62	56	54	54	35	81	74	65	59	56	55	38	82	75	67	61	57	56	39				
6	300	0.43	74	65	56	51	46	39	29	77	68	59	54	48	42	33	79	70	62	56	50	43	35			
	350	0.58	76	67	57	53	49	43	31	81	74	65	59	56	55	38	82	75	67	61	57	56	39			
	400	0.76	77	68	58	54	51	45	33	80	71	62	57	53	48	36	81	74	64	59	54	49	38			
	450	0.96	78	69	59	55	53	48	34	81	73	63	58	55	50	38	82	75	66	60	56	52	39			
500	0.39	79	70	60	53	52	48	35	81	74	64	59	56	53	38	83	76	66	61	58	54	40				
7	450	0.32	74	67	58	52	50	45	29	76	70	61	54	51	47	31	78	71	63	56	52	48	34			
	500	0.39	76	69	59	53	52	48	31	78	71	62	56	53	50	34	80	75	65	61	58	54	36			
	550	0.47	77	70	60	54	53	50	33	79	72	63	56	55	52	35	80	74	65	58	56	53	36			
	600	0.56	78	71	61	55	55	52	34	80	74	64	57	57	54	36	81	75	66	59	58	55	38			
650	0.66	79	72	62	56	56	54	35	81	75	65	58	58	56	38	82	76	67	60	59	57	39				
8	600	0.37	75	68	59	53	51	46	30	78	71	63	56	52	48	34	80	73	65	58	54	50	36			
	650	0.43	76	69	60	54	52	48	31	78	72	64	57	54	50	34	80	74	66	59	55	51	36			
	700	0.50	76	69	61	54	53	50	31	79	72	64	57	55	52	35	81	75	67	60	56	53	38			
	750	0.57	77	70	62	55	54	51	30	80	73	65	58	56	53	34	82	75	67	60	57	55	36			
800	0.65	78	71	62	56	55	53	31	80	74	66	59	57	55	34	82	76	68	61	58	56	36				
9	800	0.20	75	65	58	50	48	44	28	78	68	62	53	51	47	31	80	71	64	55	52	48	34			
	850	0.22	76	65	59	51	49	45	29	79	69	62	54	52	48	33	81	71	65	56	53	50	35			
	900	0.25	76	66	59	52	50	47	29	79	69	63	54	53	49	33	81	72	65	57	54	51	35			
	950	0.28	77	66	59	52	51	48	30	80	70	63	55	54	50	34	82	72	66	57	55	52	36			
1000	0.31	78	66	60	53	52	49	31	80	70	63	56	54	51	34	82	73	66	58	56	53	36				
10	900	0.21	76	66	59	54	52	46	29	80	70	63	56	54	49	34	82	72	65	58	55	50	36			
	1000	0.26	77	67	60	55	53	48	30	81	71	64	58	55	51	35	83	73	66	60	57	52	38			
	1100	0.31	78	68	61	56	55	50	31	82	72	65	59	57	52	36	84	74	67	61	58	54	39			
	1200	0.37	79	69	62	57	56	52	33	82	72	65	60	58	54	36	85	75	68	62	60	56	40			
1300	0.44	80	70	63	58	58	53	34	83	73	66	60	60	56	38	86	76	69	62	61	57	42				
12	1200	0.29	78	67	61	54	53	49	31	81	70	64	56	55	51	35	83	72	66	58	57	53	38			
	1400	0.39	80	69	63	56	56	52	34	82	72	66	58	58	54	36	84	74	68	60	60	56	39			
	1600	0.51	81	71	64	58	59	55	35	84	74	68	60	61	57	39	86	76	70	62	62	58	42			
	1800	0.64	82	72	66	60	61	57	36	85	75	69	62	63	59	40	87	78	71	64	64	61	43			
2000	0.80	83	74	67	61	63	59	38	86	77	70	64	65	61	42	88	79	73	65	66	63	44				
14	1500	0.16	76	64	59	51	51	45	29	79	68	62	53	53	47	33	81	70	64	55	54	49	35			
	1800	0.23	78	67	61	54	54	48	31	81	70	64	56	56	51	35	83	73	66	58	57	53	38			
	2100	0.31	80	69	63	56	57	51	34	83	72	66	59	59	54	38	85	75	68	60	60	55	40			
	2400	0.41	82	71	65	59	59	54	36	84	74	68	61	61	56	39	86	77	70	62	63	58	42			
2700	0.52	83	73	67	60	61	56	38	86	76	70	63	63	58	42	88	78	72	64	65	60	44				
16	2000	0.20	79	67	61	55	54	49	33	82	70	64	57	56	51	36	84	73	65	59	58	53	39			
	2400	0.28	81	70	63	58	58	52	35	84	73	66	60	60	55	39	86	75	68	62	61	56	42			
	2800	0.39	82	72	66	61	60	56	36	85	75	68	63	63	58	40	88	77	70	65	64	59	44			
	3200	0.50	84	73	67	63	63	58	39	87	77	70	65	65	60	43	89	79	72	67	66	62	45			
3600	0.64	85	75	69	65	65	61	40	88	78	72	67	67	63	44	90	80	74	69	69	64	47				

- Discharge sound is the noise emitted from the unit discharge into the downstream ductwork
- Min ΔPs is the static pressure drop from the unit inlet to the unit outlet with the cold damper full open
- Sound power levels are in dB, ref 10⁻¹² watts
- Sound performance based on units lined with standard dual density fiberglass lining

- All performance based on tests conducted in accordance with ASHRAE 130-2008 and AHRI 880-2011
- All NC levels determined using AHRI 885-2008 Appendix E. See Terminal Unit Engineering Guidelines.
- Dash (-) in space denotes NC value less than NC10
- Only highlighted data points are AHRI certified. Refer to page M38 for AHRI Certified Performance Listings.

AHRI Directory of Certified Performance

Titus is a charter member company and current participant in the AHRI Directory of Certified Performance. This voluntary certification program was developed by participating manufacturers in conjunction with the former Air-Conditioning and Refrigeration Institute (ARI) in the 1990's. It is currently administrated by the Air-Conditioning, Heating, and Refrigeration Institute (AHRI). The purpose of this program is to provide for the independent verification of manufacturers' published performance data. Only participating products are authorized to bear the AHRI VAV Certification Mark. Certified data may be viewed and downloaded at www.ahrinet.org.

In order to participate in this program, member companies pay annual dues based on sales volume, submit published performance data for all applicable model types, and agree to provide a number of randomly selected product samples for annual rounds of independent testing at the manufacturers' expense. All verification testing is conducted in accordance with ASHRAE Standard 130 'Methods of Testing Air Terminal Units'. These tests are conducted to verify that a manufacturer's published certified ratings are within the test tolerances outlined in AHRI Standard 880 'Performance Rating of Air Terminals'. Any failure to demonstrate the certified performance is punished by additional testing requirements, mandatory performance re-rating, monetary penalties and possible expulsion from the Certified Directory.

Product samples provided for certification testing are standard production units with standard ½" dual density fiberglass lining (unless otherwise specified) and no optional appurtenances such as add-on attenuators or heating/cooling coils. The certified ratings are measured at the standard operating points under the following test conditions:

PEDV, PEDC, PMDV, PMDC, DEDV, DMDV

- Rated airflow (cfm) – Based on an inlet velocity of 2000 fpm
- Rated Min ΔPs (in wg) – Minimum static pressure drop from the cold inlet to discharge at rated airflow with damper full open
- Rated ΔPs (in wg) – A static pressure drop of 1.5 in wg from cold inlet to discharge with the hot damper fully closed
- Rated sound power by octave band (dB, re 10⁻¹² watts) – Radiated and discharge sound performance conducted in a reverberation room that meets both the broadband and pure tone qualifications of AHRI Standard 220

PMDV, PMDC, DMDV

Inlet Size	Rated CFM	Min ΔPs	Discharge		Radiated Sound Power							Discharge Sound Power						
			H	W	2	3	4	5	6	7	2	3	4	5	6	7		
04	150	0.41	5.875	5.875	59	56	47	41	39	36	73	65	57	51	47	40		
05	250	0.42	5.875	5.875	63	59	50	43	40	35	76	69	61	54	50	46		
06	400	0.76	5.875	5.875	63	59	51	47	47	43	80	71	62	56	53	48		
07	550	0.47	8.125	7.125	66	61	53	46	45	42	79	72	63	55	55	52		
08	700	0.50	8.125	7.125	67	61	53	47	45	44	79	72	64	56	55	52		
09	900	0.25	11.125	10.125	71	62	52	45	42	35	79	69	63	54	53	49		
10	1100	0.31	11.125	10.125	69	64	56	51	52	52	82	72	65	59	57	52		
12	1600	0.51	13.125	11.125	73	66	60	58	60	58	84	74	68	60	61	57		
14	2100	0.31	16.125	12.500	72	65	56	48	46	40	83	72	66	59	59	54		
16	2800	0.39	16.125	15.125	76	66	60	52	49	45	85	75	68	63	63	58		

PEDV, PEDC, DEDV WITH INTEGRAL ATTENUATOR & MIXING BAFFLE

Inlet Size	Rated CFM	Min ΔPs	Discharge		Radiated Sound Power							Discharge Sound Power						
			H	W	2	3	4	5	6	7	2	3	4	5	6	7		
04	150	0.41	5.875	5.875	54	53	44	38	36	31	74	65	57	50	50	45		
05	250	0.47	5.875	5.875	56	54	47	40	39	35	74	67	59	51	53	50		
06	400	0.91	5.875	5.875	55	57	49	43	41	37	73	67	60	54	55	54		
07	550	0.53	8.125	7.125	63	57	51	45	45	41	74	69	60	53	56	54		
08	700	0.55	8.125	7.125	61	59	50	43	41	40	73	71	61	55	57	56		
09	900	0.23	11.125	10.125	66	57	50	45	46	45	78	68	59	55	58	57		
10	1100	0.38	11.125	10.125	64	57	49	43	42	41	79	69	61	57	59	61		
12	1600	0.44	13.125	11.125	68	62	58	55	58	57	79	70	62	58	60	61		
14	2100	0.34	16.125	12.500	67	60	53	47	48	49	78	69	62	58	61	62		
16	2800	0.40	16.125	15.125	70	61	56	50	51	51	79	69	62	59	62	64		

PEDV, DEDV WITHOUT ATTENUATOR

Inlet Size	Rated CFM	Min ΔPs	Discharge		Radiated Sound Power							Discharge Sound Power						
			H	W	2	3	4	5	6	7	2	3	4	5	6	7		
04	150	0.04	8	24.125	60	57	46	41	40	37	73	66	60	54	54	49		
05	250	0.03	8	24.125	62	59	49	42	41	37	74	66	61	56	55	50		
06	400	0.13	8	24.125	63	61	52	44	42	38	75	71	65	60	57	52		
07	550	0.10	10	24.125	64	59	53	47	43	34	74	72	63	59	56	51		
08	700	0.02	10	24.125	65	60	53	47	47	45	77	73	63	58	56	52		
09	900	0.05	12.5	28.125	64	58	53	47	45	38	77	69	63	59	57	54		
10	1100	0.01	12.5	28.125	67	62	57	55	54	43	78	71	65	63	60	55		
12	1600	0.01	15	32.125	66	62	59	53	50	44	78	74	68	64	62	58		
14	2100	0.04	17.5	40.125	66	62	55	53	50	46	74	69	66	63	63	59		
16	2800	0.03	18	48.125	66	61	54	50	50	45	76	70	66	64	62	57		





OSP & IBC seismic certifications available for Titus terminal units

seismic certified

