

INSTALLATION &  
OPERATION MANUAL



# Electric Coil

## General Information

- All fan terminals with electric coils are ETL listed.
- All single duct electric coils are ETL listed.
- All electric coil control enclosures meet NEMA 1.
- Single point power connection.

## Installation

- All terminal units with electric coils are designed to be mounted in a horizontal plane with regard to the UP arrow marked on the product label.
- Always inspect electric coils for damage prior to applying power.
- Use copper conductors only.
- All field wiring must conform to NEC and local building codes.
- Phase rotation of the incoming power is recommended when connecting three phase electric coils to balance building loads.
- Always allow a minimum clearance of 36" in front of all electric coil enclosures.
- All terminal units must be properly grounded per NEC 424-14 and 250.
- Always check product label for voltage and current data to determine proper wire size and current protection.
- These recommendations are not meant to preclude NEC requirements or local building codes that may be applicable, which are the responsibility of the installing contractor.

**CAUTION**  
**ELECTRIC SHOCK MAY RESULT**

1. DISCONNECT POWER BEFORE SERVICING UNIT.
2. DO NOT OPERATE UNIT WITHOUT CONTROL COVER INSTALLED.

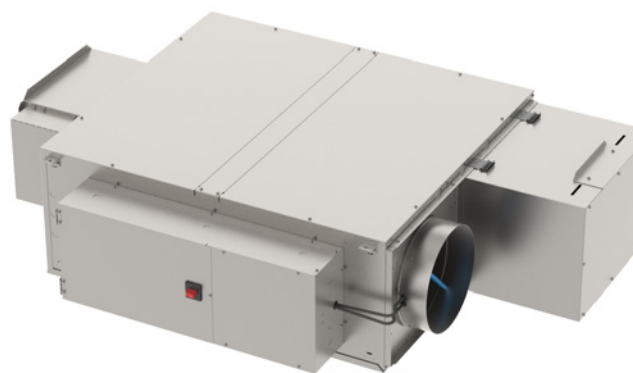

Fan Terminal Unit with Heater

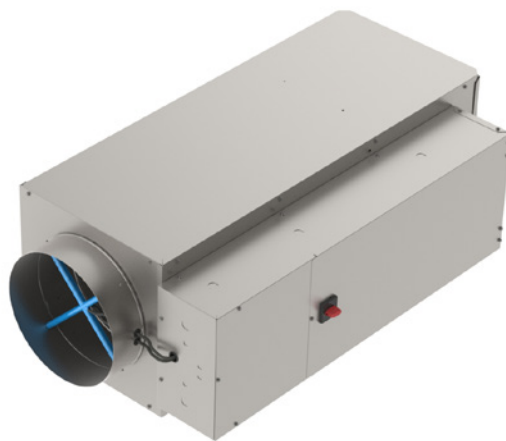

Single Duct Terminal Unit with Heater

## Data Label

All electric coils are provided with a product label affixed to the control enclosure cover. This label contains all necessary information regarding electrical power and circuit protection requirements, as specified by UL. See Figure 1.

		<b>FAN UNIT</b>	
<b>MODEL NO</b>	<b>DTQS</b>	<b>CODE 99-361901-B 6 REV:</b>	
<b>MOTOR</b>	<b>VOLT 277</b>	<b>PHASE 1</b>	<b>HZ 60</b>
	<b>HP 1/6</b>	<b>FLA(EA) 1.40</b>	
<b>HEAT</b>	<b>VOLT 277</b>	<b>PHASE 1</b>	<b>HZ 60</b>
	<b>KW 6.0</b>	<b>AMPS 21.66</b>	
<b>MOTOR(S) ARE THERMALLY PROTECTED</b>		<b>MAXIMUM OVERCURRENT</b>	
<b>MIN. SUPPLY CIRCUIT AMPS 1.38 AMP</b>		<b>PROTECTION = 15 AMP</b>	
<b>XXXXXXXXXXXXXXXXXXXXXXXXXXXX</b>			
<b>MAX. OUTLET AIR TEMPERATURE 200° F</b>			
<b>UNIT DESIGNED TO OPERATE AT NO LESS THAN 0.2 IWG STATIC PRESSURE</b>			
<b>ZERO CLEARANCE FROM UNIT, CONNECTED DUCT AND/OR PLENUM</b>			
<b>TO COMBUSTIBLE MATERIAL.</b>			

Figure 1

## Heater Control Enclosure

Figure 2 shows the interior of a typical electric coil control enclosure. Various components contained within this enclosure are necessary for the safe operation of the product. An interlocking safety door disconnect switch is recommended, but not required. It prevents access to the enclosure until all ungrounded conductors are disconnected from the electric coil circuit. If an optional disconnect switch is not ordered, a terminal block will be provided for single point electrical hook-up. A ground lug is provided to insure proper grounding of the terminal unit housing and enclosure. Optional line fuses and fan motor fuses provide overcurrent protection, if permitted by local building codes. An air flow switch is always provided to lock-out the coil when there is no air flow across the elements. An automatic reset thermal cut-out is required to de-energize elements whenever discharge temperature is excessive. The

coil will resume operation when discharge temperatures decrease. An optional manual reset thermal cut-out will protect the elements in the event of a thermal cut-out failure and prevent the coil from operating until qualified service personnel can make repairs. Fuse links are required on all single duct electric coils to provide safety in event of a thermal cut-out failure. Fuse links must be replaced as they cannot be reset. A control transformer is provided whenever a 24 V circuit is required. PE switches may be load bearing on small pneumatically-controlled electric coils, or pilot duty when current loads require magnetic contactors. Optional mercury contactors are available for extra long service life and / or silent operation. In addition to these components, fan powered terminals may include an SCR motor speed control and a fan relay.

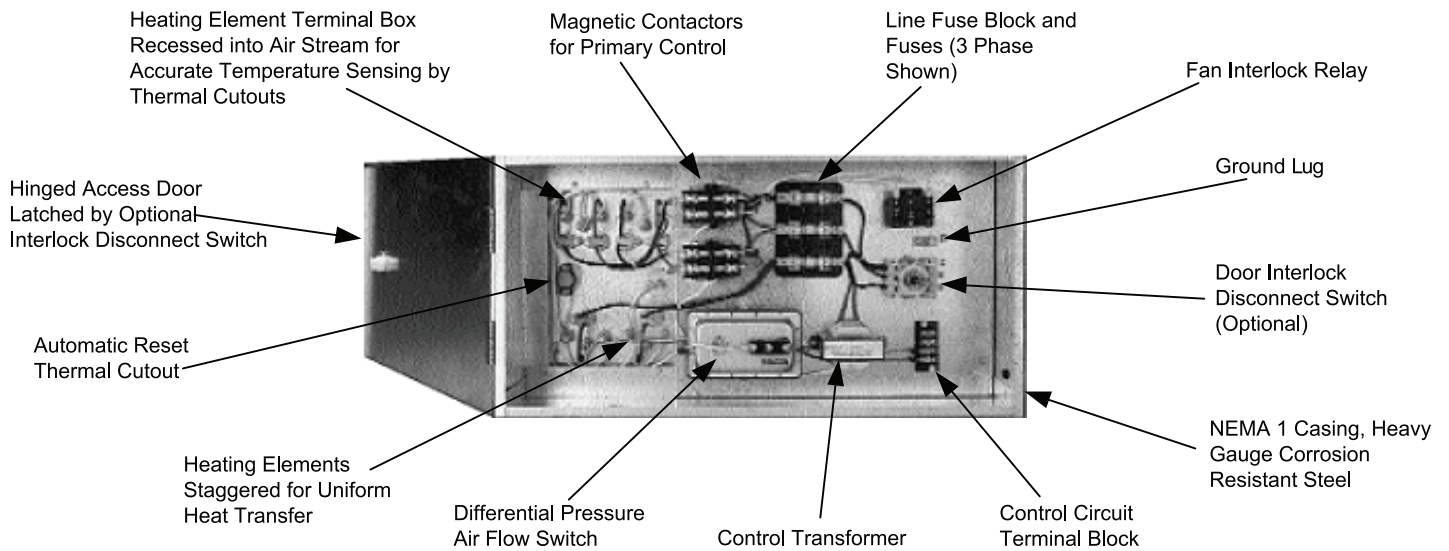

Figure 2

## Wiring Diagrams

- Figure 3 Typical pneumatic parallel fan powered terminal with load bearing PE switches.
- Figure 4 Typical pneumatic parallel fan powered terminal with contactors.
- Figure 5 Typical pneumatic series fan powered terminal with load bearing PE switches.
- Figure 6 Typical fan powered terminal with factory wired controls.
- Figure 7 Typical electronic fan powered terminal with field mounted controls.
- Figure 8 Typical electronic single duct terminal with field mounted controls.
- Figure 9 Typical pneumatic single duct terminal with contactor.

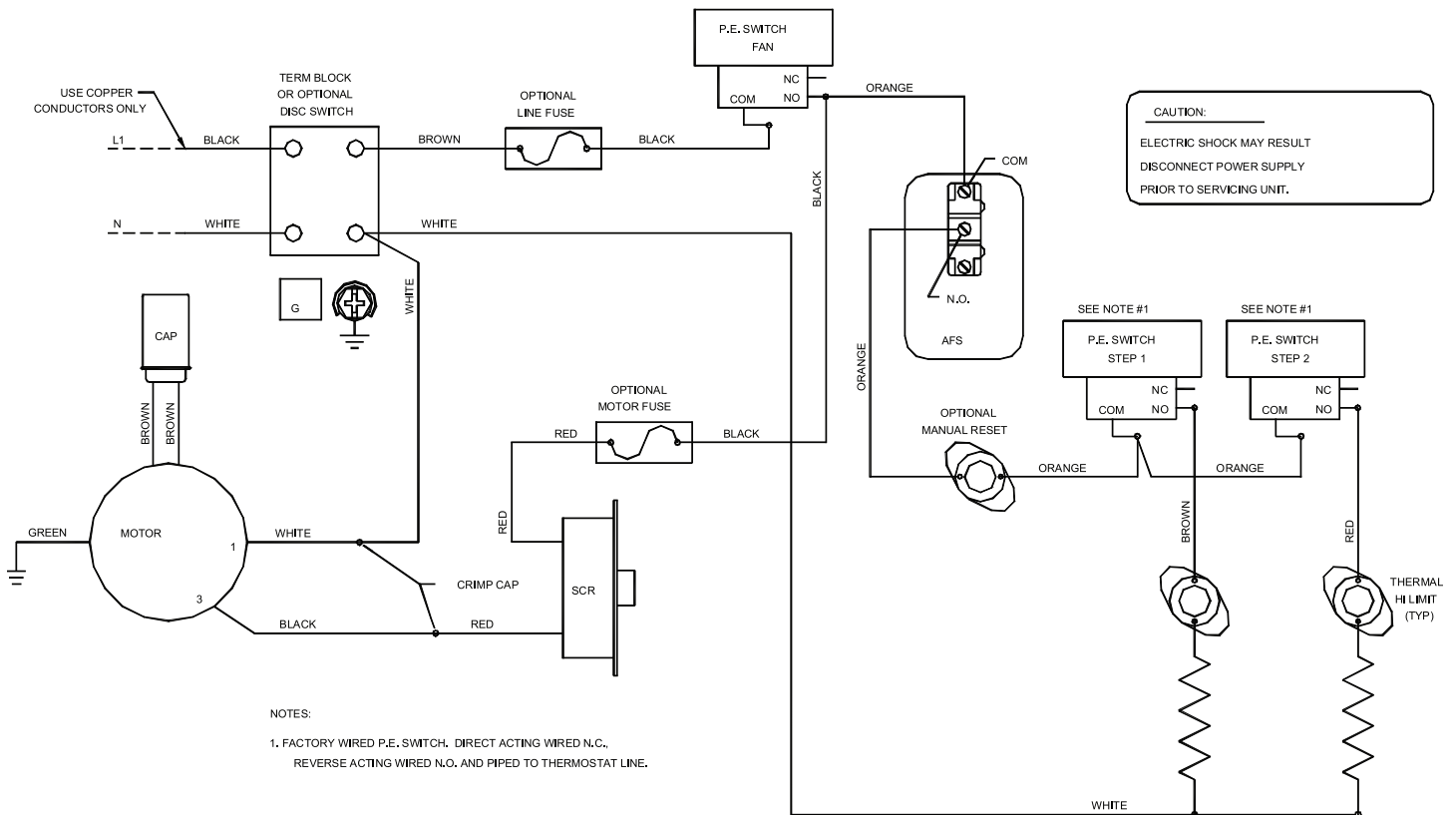

Figure 3  
Pneumatic Parallel (Variable Volume) Fan Powered Terminal  
Electric Reheat, 277V, 1, 2 Stage, 2 Element

Wiring Diagrams (continued)

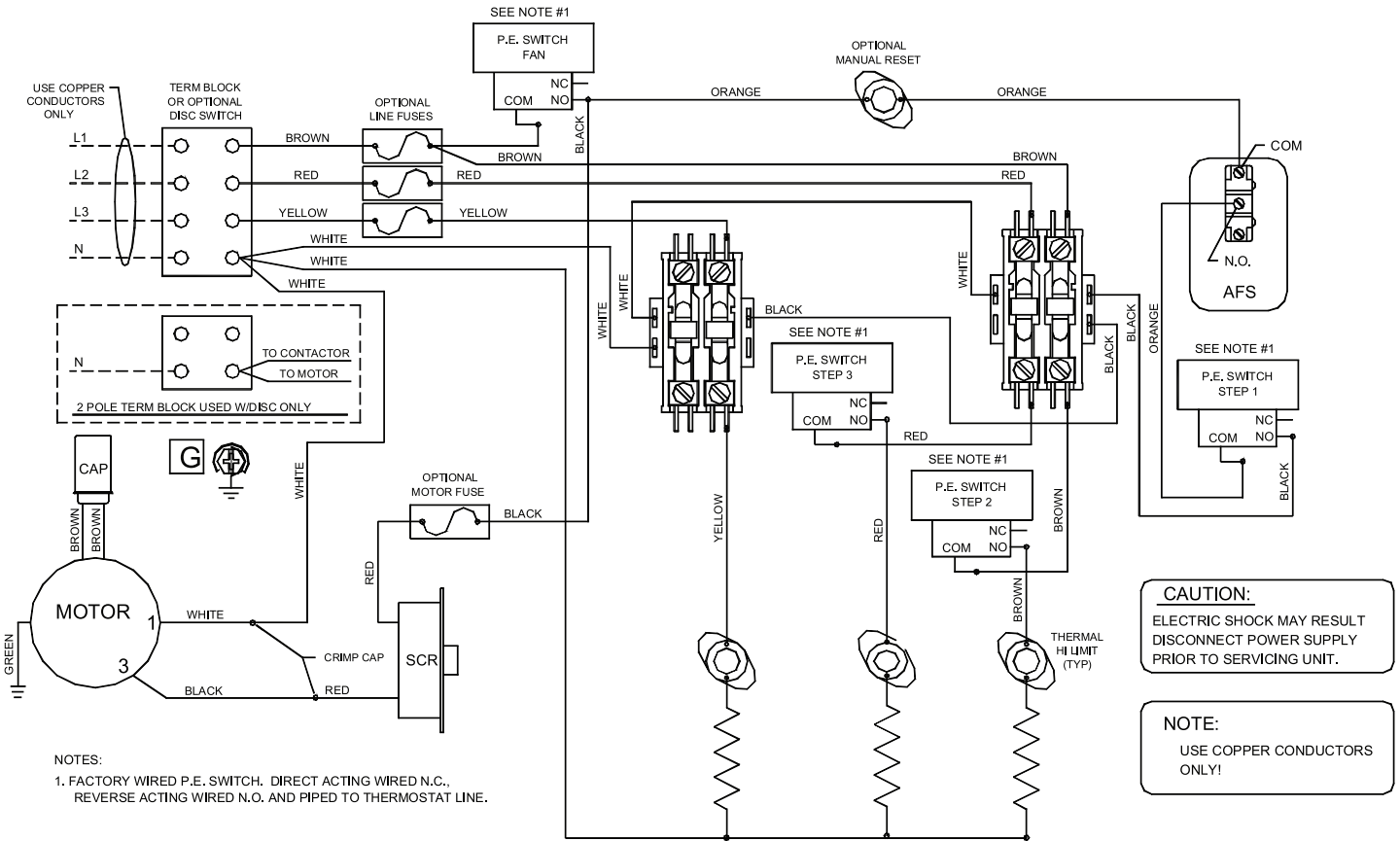

Figure 4  
Pneumatic Parallel (Variable Volume) Fan Powered Terminal  
Electric Reheat, 480V, 3, 3 Stage, 3 Element

## Wiring Diagrams (continued)

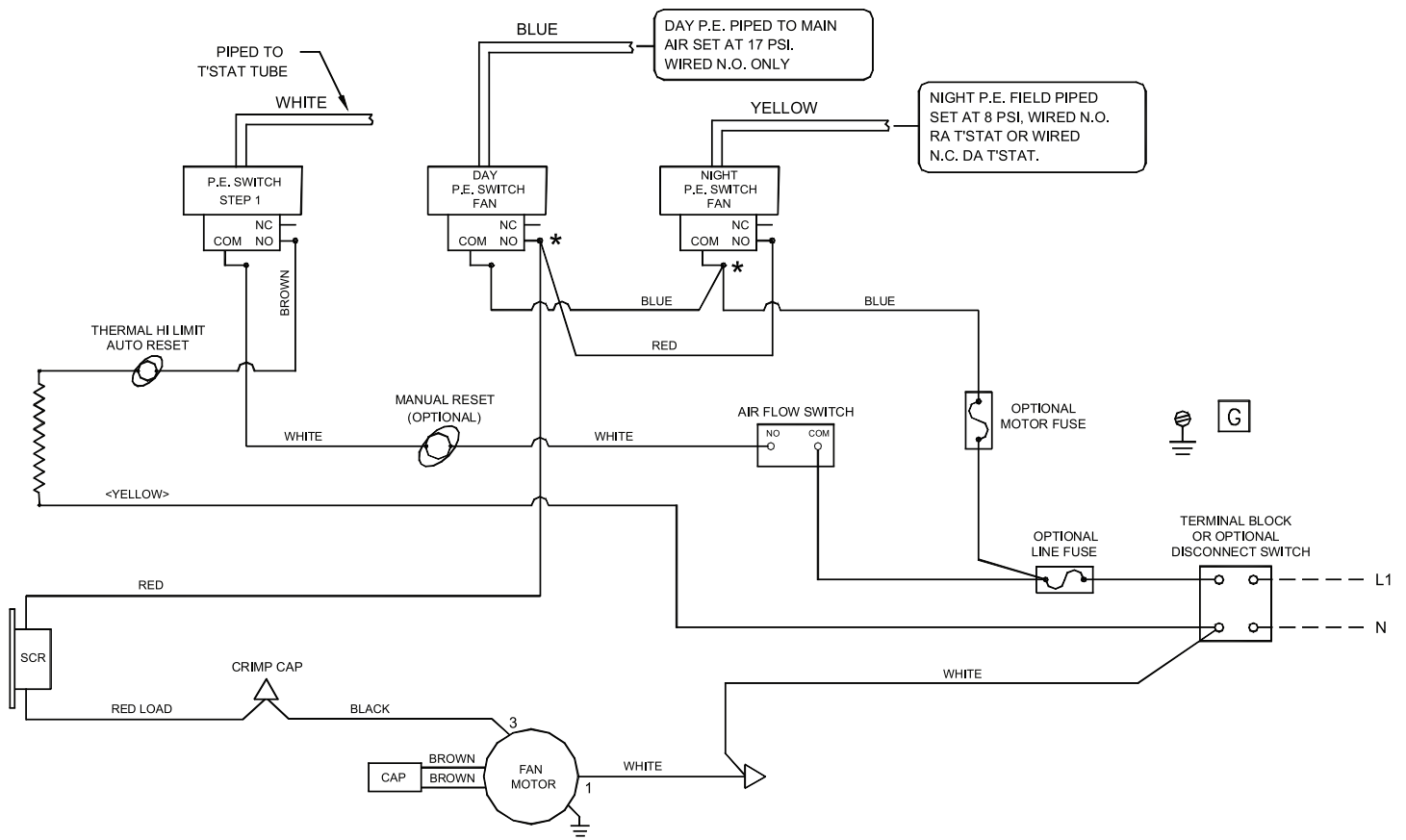
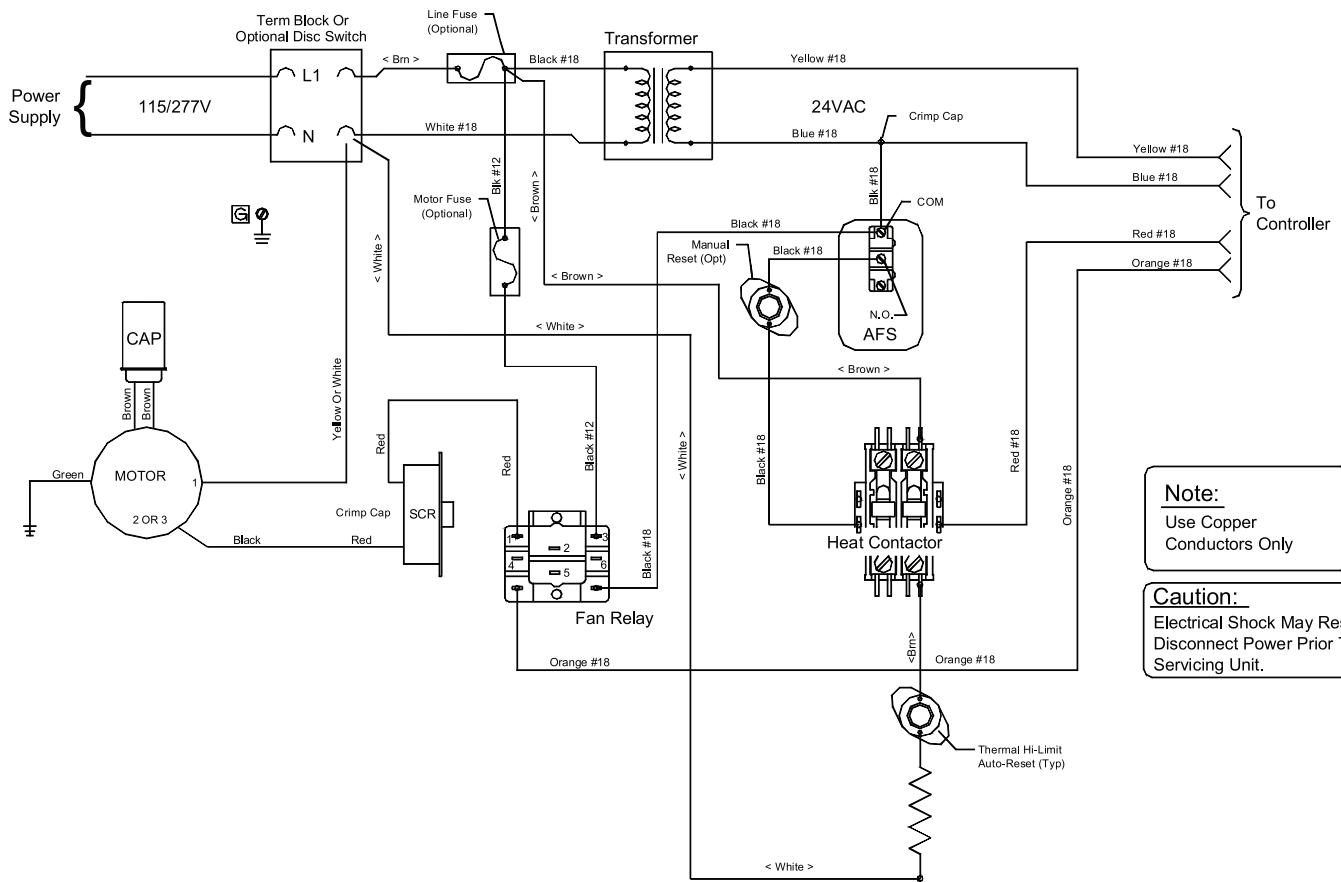

Figure 5  
Pneumatic Series (Constant Volume) Fan Powered Terminal  
Electric Reheat, 277V, 1, 1 Stage, 1 Element

## Wiring Diagrams (continued)



**Note:**  
Use Copper  
Conductors Only

**Caution:**  
Electrical Shock May Result.  
Disconnect Power Prior To  
Servicing Unit.

Figure 6  
Typical Fan Powered Terminal, Factory Mounted Controls  
Electric Reheat, 277V, 1, 1 Stage, 1 Element



## Wiring Diagrams (continued)

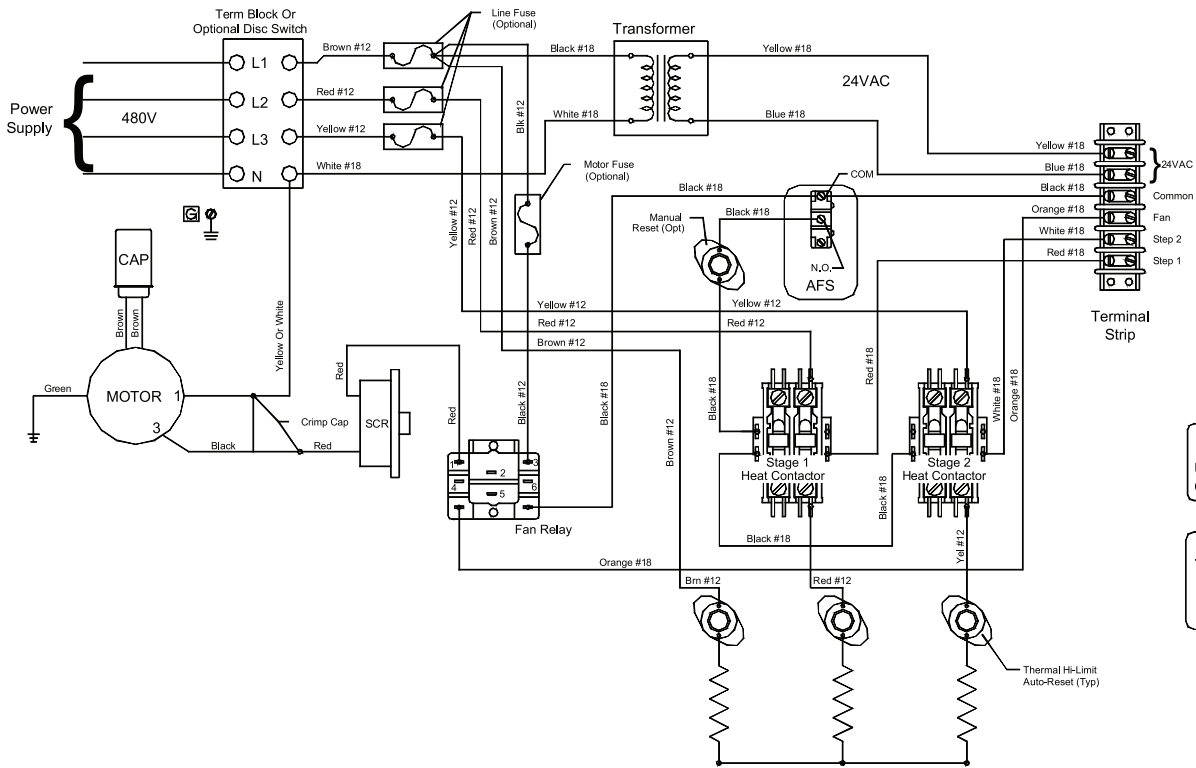

**Note:**  
Use Copper  
Conductors Only

**Caution:**  
Electrical Shock May Result.  
Disconnect Power Prior To  
Servicing Unit.

Figure 7  
Typical Fan Powered Terminal, Field Mounted Controls  
Electric Reheat, 480V, 3, 2 Stage, 3 Element

Wiring Diagrams (continued)

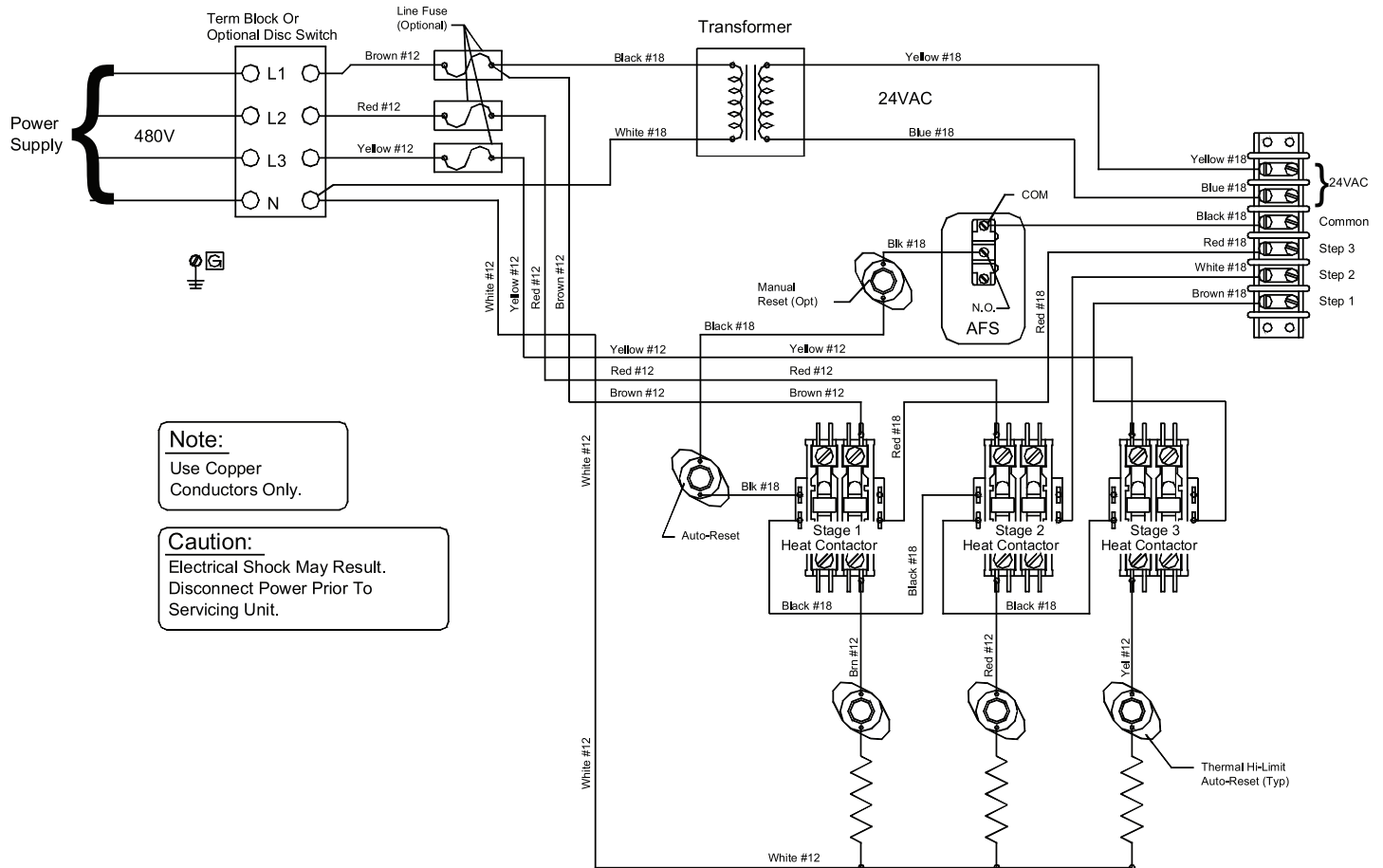

Figure 8  
Typical Single Duct Terminal, Field Mounted Controls  
Electric Reheat, 480V, 3, 3 Stage, 3 Element

## Wiring Diagrams (continued)

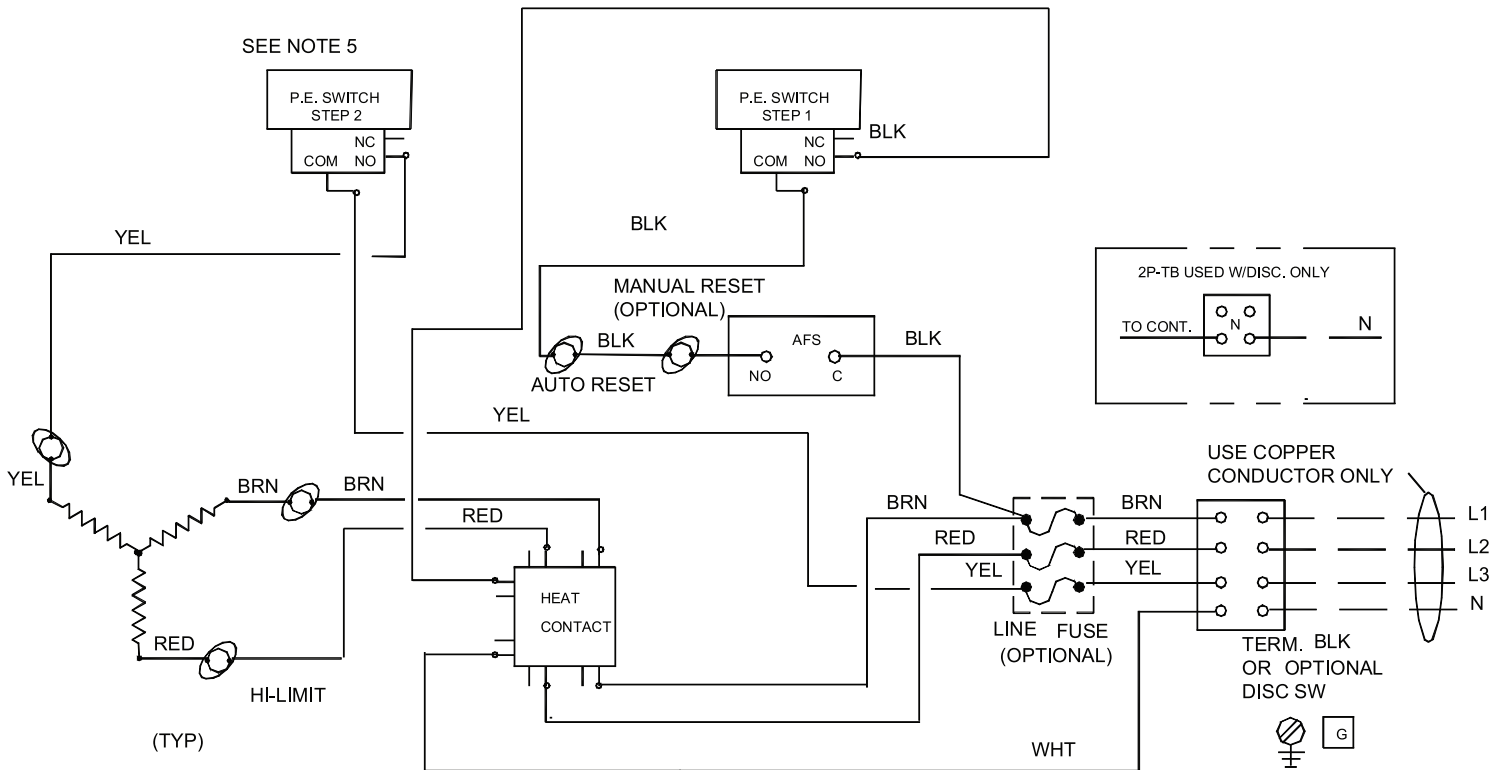
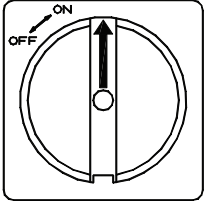
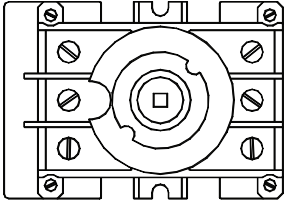
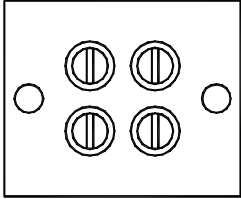
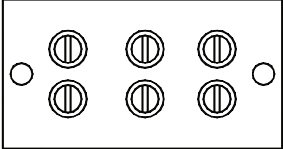
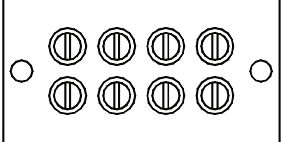
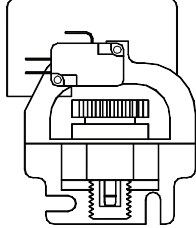
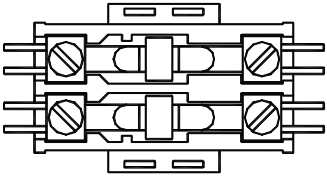
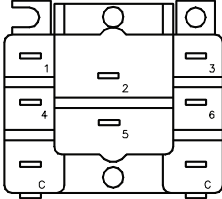
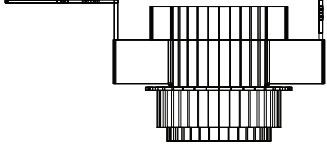
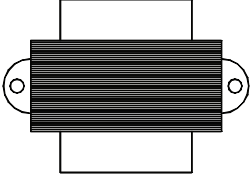
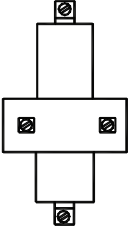
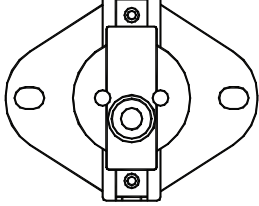
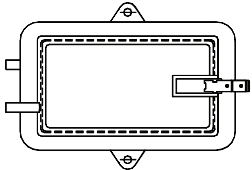



Figure 9  
Pneumatic Single Duct Terminal  
Electric Reheat, 480V, 3, 2 Stage, 3 Element

## Electric Coil Components

Description	Vendor Model Number*	Part Number
Door Disconnect Handle	ABBOHB1AH1	10329301
Door Interlock Disconnect, 3 Pole, 40 Amp	ABBOT32ES	10329101
Door Interlock Disconnect, 3 Pole, 80 Amp	ABBOT63ES	10329201
Adapter Kit: Includes - Adapter plate, Interlocking Disconnect Switch, Selector Handle, Square Shaft, #8 x 1/2 TEK Screw		
3 Pole, 40 Amp		31489601
3 Pole, 80 Amp		31489602
Power Terminal Block, 2 Pole	1102, 55A or 9-85-2, 85A	10052301
Power Terminal Block, 3 Pole	1103, 85A or 9-85-3, 85A	10052401
Power Terminal Block, 4 Pole	1104, 55A or 9-85-4, 85A	10055001
PE Switch 1 Step	CCE-3011B or P658E1001	10000901
PE Switch 2 Step	CCE-3012B	10199801
PE Switch 3 Step	CCE-3013B	10199802
Magnetic Contactor, 24 Volt, 30 Amp, 2 pole	3100-20Q334 or R8242B1006	10054401
Magnetic Contactor, 208 / 240 Volt, 30 Amp, 2 Pole	3100-20U334 or R4242B1013	10054404
Magnetic Contactor, 277 Volt, 30 Amp, 2 Pole	3100-20V334 or R4242B1021	10054403
Relay, 24 Volt, Double Pole Double Throw	9100266Q34	10161801
Relay, 24 Volt, Single Pole Single Throw (Fan)	9100401Q34	10156901
Auto Reset Thermal Cutout (All Models)	60TX01 or 402-834	10052101
Manual Reset Thermal Cutout (All Models)	60T14L160F	10118801
Transformer 208 / 240 / 24 Volt, 50 VA	4000-09AW18AE34	10057501
Transformer 277 Volt / 24 Volt, 50 VA	4000-03AW18AE34	10006601
Transformer 480 / 24 Volt, 50 VA	4000-04AW04K34	10100301
Air Flow Switch	DFS221112 or RH1505-DO	10269501
Air Flow Switch Sensor, 4" Length	3000018 or 1729	10057201
Air Flow Switch Sensor, 6" Length	3000017 or 1729-22	10057202
Mercury Contactor, 24 Volt Holding Coil, 35 Amp, 1 Pole	35NO - 24A or 1035A24AC	10162001
Mercury Contactor, 24 Volt Holding Coil, 35 Amp, 2 Pole	235NO - 24A or 2035A24AC	10162002
Mercury Contactor, 24 Volt Holding Coil, 35 Amp, 3 Pole	335NO - 24A or 3035A24AC	10162003
Mercury Contactor, 208 / 240 Volt Holding coil, 35 Amp, 1 Pole	35NO - 220A or 1035A208ACDV	10162201
Mercury Contactor, 208 / 240 Volt Holding Coil, 35 Amp, 2 Pole	235NO - 220A or 2035A208ACDV	10162202
Mercury Contactor, 208 / 240 Volt Holding Coil, 35 Amp, 3 Pole	335NO - 220A or 3035A208ACDV	10162203
Mercury Contactor, 277 Volt Holding Coil, 35 Amp, 1 Pole	35NO - 277A or 1035A277AC	10162301
Mercury Contactor, 277 Volt Holding Coil, 35 Amp, 2 Pole	235NO - 277A or 2035A277AC	10162302
Mercury Contactor, 277 Volt Holding Coil, 35 Amp, 3 pole	335NO - 277A or 3035A277AC	10162303
Mercury Contactor, 24 Volt Holding Coil, 60 / 50 Amp, 1 Pole	60NO - 24A or 1050A24AC	10162004
Mercury Contactor, 24 Volt Holding Coil, 60 / 50 Amp, 2 Pole	260NO - 24A or 2050A24AC	10162005
Mercury Contactor, 24 Volt Holding Coil, 60 / 50 Amp, 3 Pole	360NO - 24A or 3050A24AC	10162006
Mercury Contactor, 208 / 240 Volt Holding Coil, 60 / 50 Amp, 1 Pole	60NO - 220A or 1050A208ACDV	10162204
Mercury Contactor, 208 / 240 Volt Holding Coil, 60 / 50 Amp, 2 Pole	260NO - 220A or 2050A208ACDV	10162205
Mercury Contactor, 208 / 240 Volt Holding Coil, 60 / 50 amp, 3 Pole	360NO - 220A or 3050A208ACDV	10162206
Mercury Contactor, 277 Volt Holding Coil, 60 / 50 Amp, 1 Pole	60NO - 277A or 1050A277AC	10162304
Mercury Contactor, 277 Volt Holding Coil, 60 / 50 Amp, 2 Pole	260NO - 277A or 2050A277AC	10162305
Mercury Contactor, 277 Voil Holding Coil, 60 / 50 Amp, 3 Pole	360NO - 277A or 3050A277AC	10162306

## Electric Coil Components (continued)

 <p>Door Disconnect Handle</p>	 <p>Door Disconnect Sub Base</p>	 <p>Terminal Block 2 Pole</p>
 <p>Terminal Block 3 Pole</p>	 <p>Terminal Block 4 Pole</p>	 <p>PE Switch</p>
 <p>Magnetic Heat Contactor</p>	 <p>Relay 24V SPST (Fan) Relay 24V DPDT</p>	 <p>Auto Reset Thermal Cutout (All Models)</p>
 <p>Transformer</p>	 <p>Mercury Contactor (1 Pole)</p>	 <p>Manual Reset Thermal Cutout</p>
 <p>Air Flow Switch</p>		 <p>Air Flow Sensor</p>

## Heater Rack Replacement

On the fan powered terminals, the elements rack is located at the discharge end of the terminal under a metal heater rack cover held with screws. On the single duct terminals, the element rack is located inside the control enclosure on the side of the terminal.

1. Turn power off to the terminal unit before servicing.
2. Locate element rack header plate.
3. Before removing wires from the element rack header plate, mark the wires and where they are connected, to insure they are reconnected correctly on the new element rack.
4. Remove the wires and screws holding the header plate in the coil housing.
5. Insert the new element rack into the coil housing and replace the screws to secure the element rack.
6. Replace wires in the same locations as removed from old element rack.
7. Replace enclosure metal cover or door before turning on power to the electric coil.

Flanges mount to discharge of terminal unit.

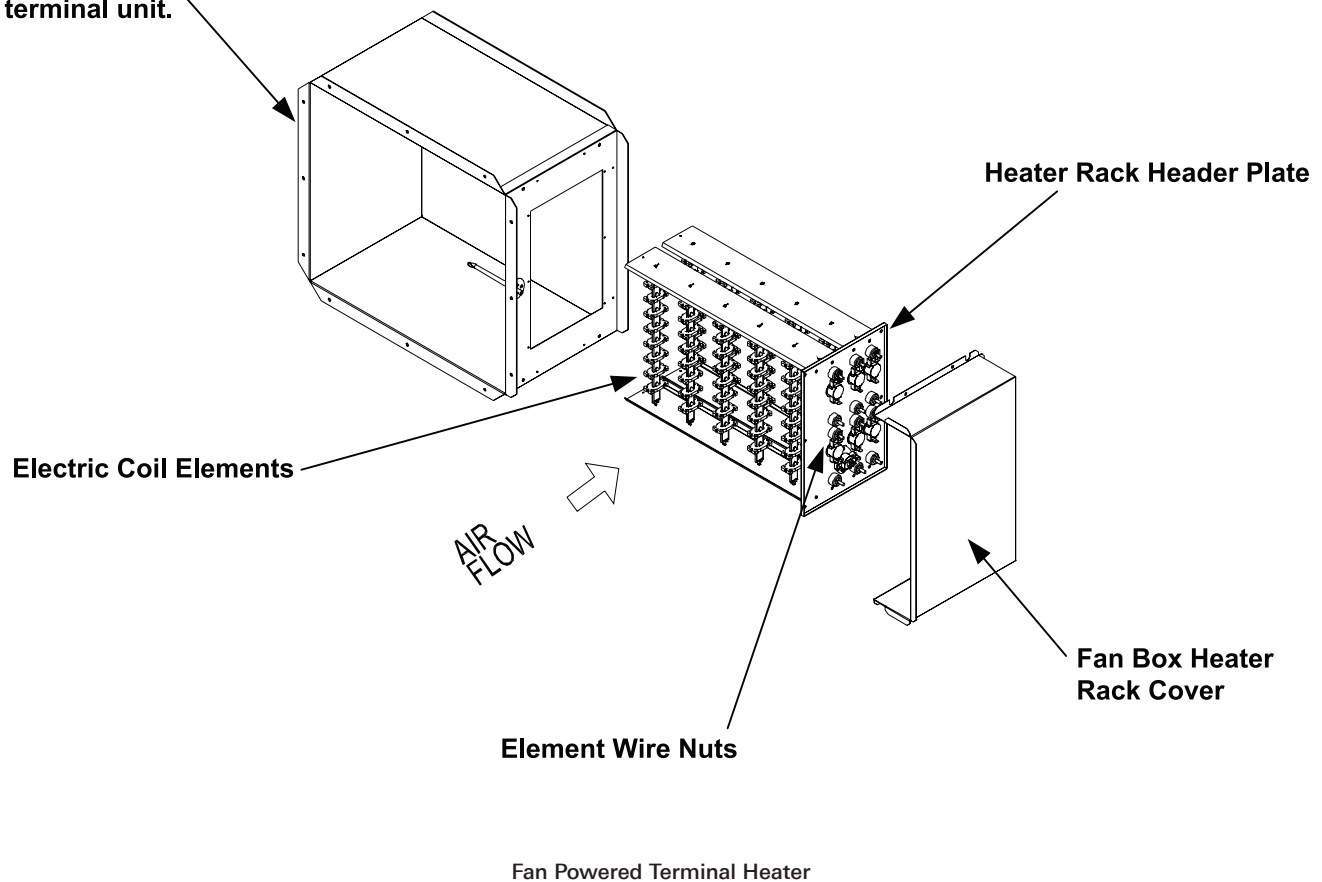

## Heater Rack Replacement

Problem	Possible Cause	Possible Solution
Heater will not operate or heat	Disconnect or circuit breaker	May be in off position
	Fuses	May be blown, wrong amp size; replace with new fuses of correct size
	Manual reset cutout	If opened, manually reset it
	Air switch	Insufficient air flow or tube is disconnected from air pickup probe to air switch
	Automatic reset thermal cutout	Opened circuit from over heating, increase airflow
	P E switch	Check if wired DA/NC or RA/NO terminal and common
	Electronic controller	Check to see if controller is setup for proper heat sequence
	Element wire burned out	Use ohm meter to check for resistance, no resistance, replace with new elements
	Transformer	Check to see if getting 24 volts on secondary side +/-2 volts or replace new
	Heat contactor	Won't close contacts with power to holding coil terminals; replace with new contactor
Wiring problem	Check if correctly wired per wire diagram	
Heater Cycles	Air switch opening and closing	Not sufficient air flow at times, increase airflow
	Transformer	Short on volt amps for full operation of equipment; need larger transformer
	Contacting chattering	Transformer under sized or air switch not staying closed; need larger transformer or more air for air switch
	Automatic reset thermal cutout	Increase air flow or look for insulation obstructing airflow over coil



605 Shiloh Rd  
Plano TX 75074  
ofc: 972.212.4800  
fax: 972.212.4884

Redefine your comfort zone.™ | [www.titus-hvac.com](http://www.titus-hvac.com)

