

THB SERIES A

ENGINEERING GUIDE

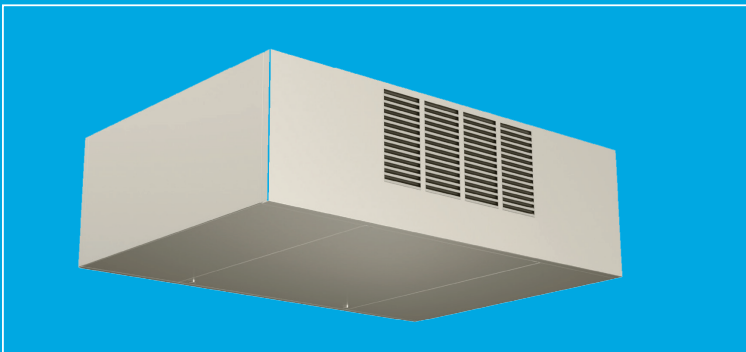

THBE

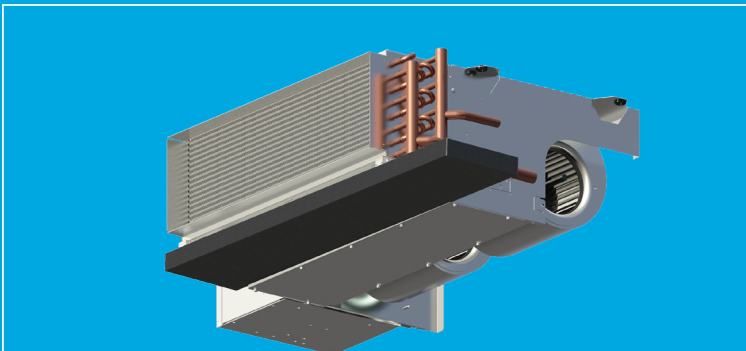

THBC

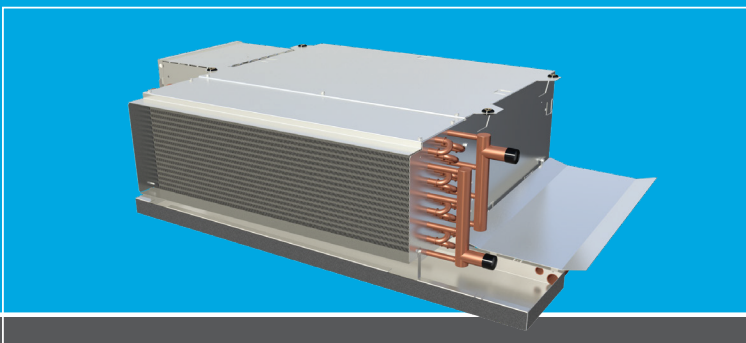

THBP



TABLE OF CONTENTS

Features and Benefits	3
Construction Features	4
Standard and Optional Features	6
Coils, Unit Weights	8
Ratings	9
Electric Heat	10
Fan Performance Curves (PSC Motors)	12
Motor, Fan Data (PSC Motors)	13
Fan Performance Curves (EC Motors)	15
Motor, Fan Data (EC Motors)	16
Sound Data	17
Dimensional Data	20
Model THBP & THBC External Feature Space Requirements	20
Model THBC With Cooling & Electric Heat	21
Model THBC With Electric Heat	22
Model THBP With Electric Heat	23
Model THBP With Electric Heat - Cooling & Heating	24
Model THBP Bottom Return With Optional Electric Heat	25
Model THBP Telescoping Bottom Panel	26
Model THBP & THBC Solid Bottom Access Panel	27
Model THBE Rear Return	28
Model THBE Bottom Return	30
Guide Specifications	33



NOTES:

- A web-based Computer Selection Program, “Selection software,” is available to facilitate the selection process. Contact your representative to obtain access to this powerful and time-saving program.
- Some drawings are not shown in this catalog.
- All data herein is subject to change without notice.
- Drawings not for installation purposes; refer to IOM manual.
- cETLus Report Number 539840.
- Content not for contractual purposes; use Selection software output and separate construction submittal drawings located on web

FEATURES AND BENEFITS

HIGH PERFORMANCE

Titus THB Series horizontal low profile fan coil units are designed to maximize flexibility of selection and installation.

The units are also designed to exceed the stringent quality standards of the institutional market, while remaining cost competitive in the light commercial segment of the market.

Titus horizontal fan coil units set the standards for quality, flexibility, and competitive pricing.

DESIGN FLEXIBILITY

The extensive variety of standard options available on the THB Series units are where you find the versatility to fit any HVAC system designer's needs.

Options include: rear or bottom return, rear ducted return, solid or telescoping bottom panels for unit recessing, single wall stainless steel drain pans, electric heat and condensate pumps with single point power connection. All electric heat units are listed with cETLus as an assembly and carry the cETLus label.

Units comply with the latest edition of AHRI Standard 440 for testing and rating fan coil units, are certified, and display the AHRI symbol.

High Efficiency motors, fan relays, disconnects and fusing mean easier coordination between mechanical and electrical trades.

Coil options allow for 2 through 6 row chilled water or 2 through 5 row DX cooling coils. One or two row hot water or standard steam coils may be placed in the preheat or reheat position.

Silent solid state relays are available for electric heat control in sound sensitive environments.

High static ECM option provides versatility and adjusts for applications that exceed .25" of external static pressure.

CONVENIENT INSTALLATION

THB Series fan coil units are shipped completely assembled, reducing field installation time and labor. All units are thoroughly inspected and tested prior to shipment, reducing potential problems at startup. Motor wiring is brought to a junction box on the outside of the unit casing, reducing electrical hook-up time.

THB Series fan coil units have an electrical enclosure on the side of the unit. The expansive compartment allows for easy access to electrical components, terminal blocks and wiring.

Factory furnished valve packages assure proper fit, operation and performance.

QUALITY PRODUCT

Concealed Model THB Series fan coil units are built from galvanized steel. Exposed Model THBE cabinetry is powder coated galvanized steel.

Standard insulation is 3/8" elastomeric closed cell foam, complying with UL 181 and NFPA 90A.

Units, with or without electric heat, are cETLus listed and labeled. All wiring is in compliance with NEC.

THB Series fan coil units have a removable fan assembly. The entire fan assembly can be removed from the unit and serviced easily on a workbench.

CONSTRUCTION FEATURES

MODEL THBP

THB Series fan coils have many standard and optional features which are unique to the industry (see page 6 for a complete listing).

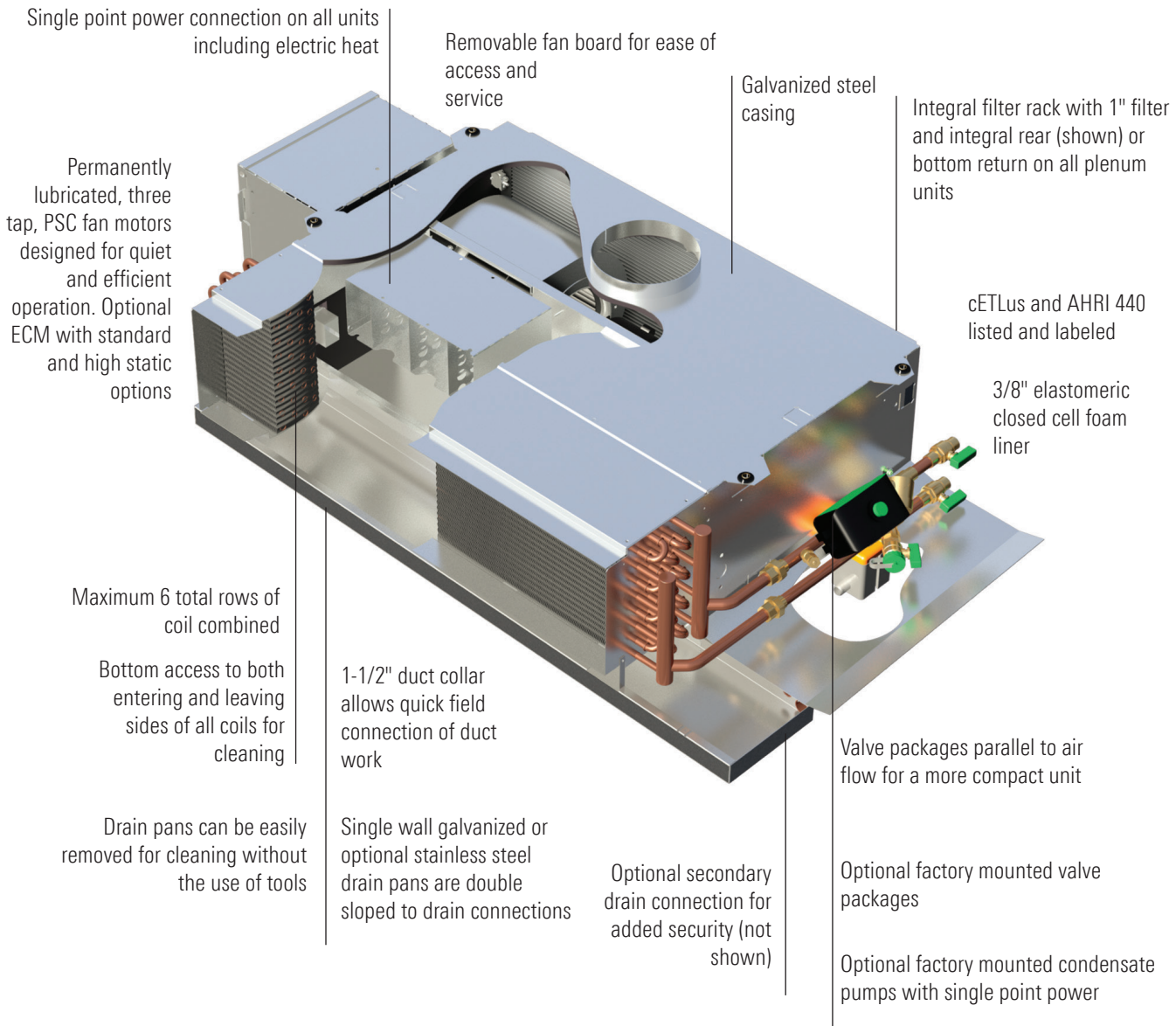

MODEL THBE

Horizontal Exposed Cabinet

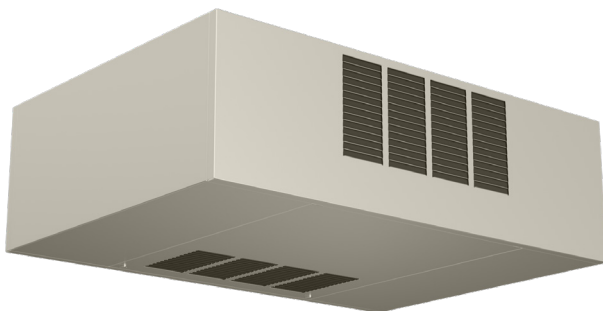

MODEL THBC

Horizontal Free Return

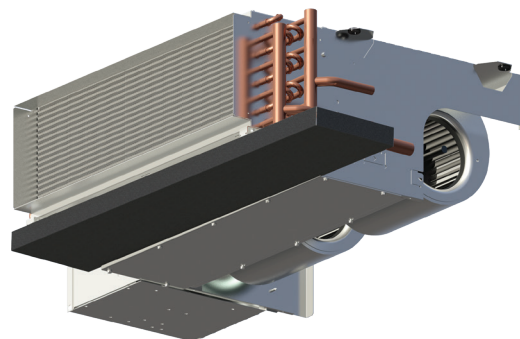

CONSTRUCTION FEATURES

MODELS THBC / THBP / THBE

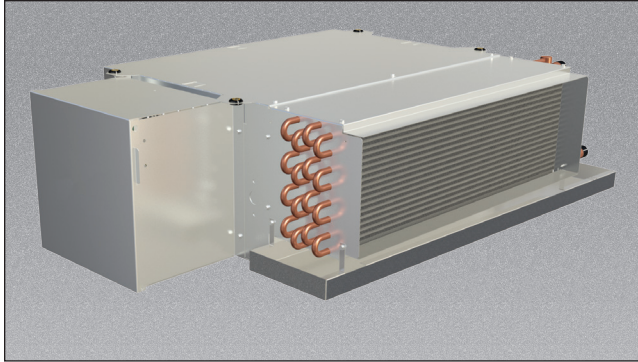

ELECTRICAL ENCLOSURE

The bottom access electrical enclosure with additional side access provides access to a spacious electrical compartment. This compartment houses electric heat and control components. Terminal strips are furnished for simple power and control wiring connections. Multiple knockouts allow wiring entries from either side of the compartment.

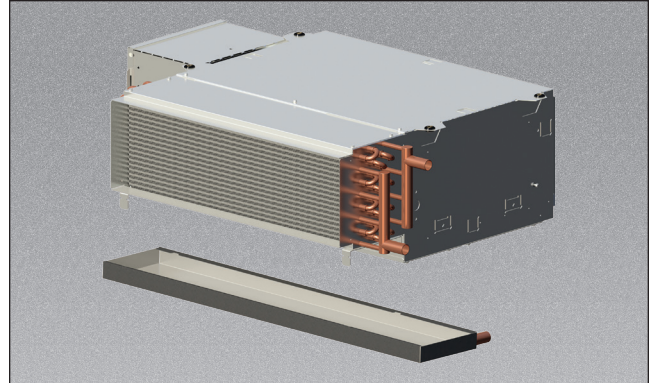

DRAIN PAN

The THB Series drain pan is easily removable for cleaning, utilizing a patent-pending tool-free design. Standard drain pans are single wall galvanized steel with an option for stainless steel. Drain pans are available with secondary drain connection. All drain pans are externally insulated with closed cell foam.

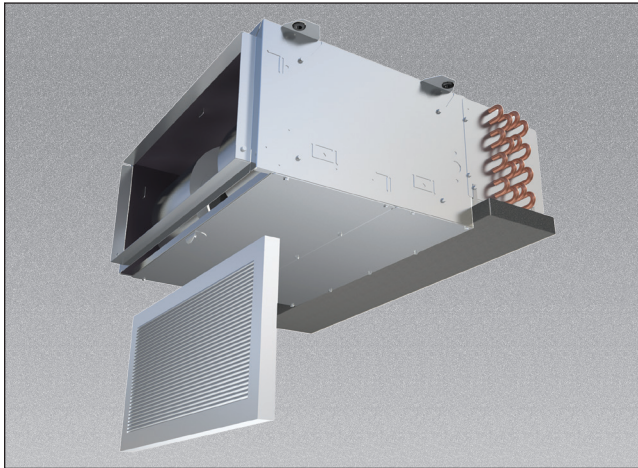

FILTERS

One inch throwaway filters are tight fitting to prevent air bypass. Filters are easily removable from the bottom of the unit.

COILS

All fan coils are available in 2 or 4 pipe configurations. The heating coil may be placed in the reheat or preheat position. Heating and cooling coils are available with right, left or opposite side connections.

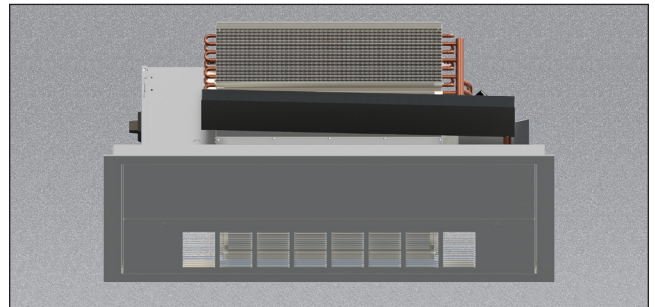

TELESCOPING BOTTOM PANEL

The telescoping bottom panel allows for fully recessing the unit while permitting service access into the ceiling plenum. The architectural ceiling panel is finished with a durable powder coat paint.

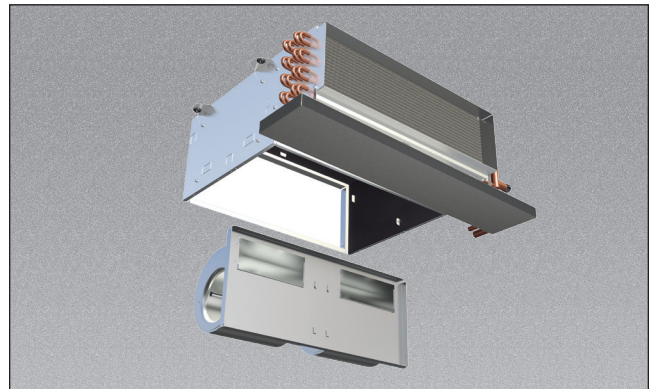

FAN DECK

The fan assembly is easily removed without disconnecting the ductwork for service access to motors and blowers at, or away from the unit.

STANDARD AND OPTIONAL FEATURES

STANDARD FEATURES

Construction

All Units

- AHRI 440 certified and labeled
- 3/8" elastomeric closed cell foam insulation
- Galvanized steel construction
- 1 1/2" duct discharge collar
- Four point hanger mounting brackets

Plenum units

- Integral filter rack with 1" throwaway filter
- Integral rear return

Exposed units

- Stamped louver supply and return air grilles
- Durable powder coat paint
- 18 gauge bottom panel construction

Coils

- Cooling - 2 to 6 row chilled water or 2 to 5 row DX, heat pump compatible
- Heating - 1 or 2 row hot water or steam – reheat or preheat position
- 6 total rows of cooling and heating coils maximum
- 3/8" coil tube diameter
- 10, 12 or 14 fins per inch
- High efficiency aluminum fin surface for optimizing heat transfer and air pressure drop
- Left or right hand, same or opposite side connections on four pipe systems
- Access to entering and leaving air sides for cleaning
- Removable for service
- Manual air vents

Drain Pans

- Single wall, galvanized steel, externally insulated – fire retardant and antimicrobial
- Double sloped to drain connection
- Tool-free removal
- 7/8" primary drain connection

Fan Assemblies

- Forwardly curved, DWDI centrifugal type
- 115 volt, single phase, three speed PSC motors
- Quick disconnect motor connections
- Removable fan/motor deck for service

Electrical

- cETLus listed for safety compliance
- Electrical junction box for field wiring terminations

Electric Heat

- cETLus listed as an assembly for safety compliance
- Integral electric heat assembly with removable elements for easy service
- Automatic reset primary and back-up secondary thermal limits
- Single point power connection

OPTIONAL FEATURES

Construction

All units

- Rubber isolated hanger brackets

Plenum units

- Bottom return
- Rear ducted return
- 1" pleated filters (MERV 8 & 13)
- Spare 1" throwaway filters
- Telescoping bottom access panels

Exposed units

- 1" pleated filters (MERV 8 & 13)
- Double deflection discharge grille
- Ducted supply and/or return

Coils

- 1/2" coil tube diameter
- Automatic air vents
- Stainless steel coil casings

Drain Pans

- Stainless steel construction with external insulation
- 5/8" secondary drain connection
- Auxiliary drip pans, galvanized or stainless steel

Condensate Pump

- Single point power
- Plenum rated
- Maintenance free
- Quiet operation

Piping Packages

- Factory assembled – shipped loose for field installation
- Unit mounted - shipped from factory with structural supports
- 1/2" and 3/4", 2 way and 3 way normally closed, two position electric motorized valves
- Floating point modulating control valves
- 0-10V proportional control valves
- High pressure close-off actuators (125 PSIG)
- Isolation ball valves with memory stop
- Fixed flow control devices
- Unions and P/T ports
- Y strainer with blowdown

Thermostats

- Remote mounted analog, digital display or programmable
- 2 and 4 pipe control sequences
- Automatic and manual changeover
- Integral three speed fan switches
- 24V floating point control
- 0-10V proportional control

Fan Assemblies

- 208-230 & 277 volt, single phase, three speed PSC motors
- 115, 208-230 & 277V, single phase, three speed EC motors
- 115, 208-230 & 277V, single phase, high static three speed EC motors
- 115, 208-230 & 277V, single phase, variable speed EC motors

Electrical

- SCR fan speed controller (high speed only)
- Integrated circuit board with fan relays and on board transformer
- Toggle disconnect switch
- Condensate overflow switch (drain pan)
- Main fusing
- Unit and remote mounted 3-speed fan switches
- Freezestat
- Dirty filter switch
- Discharge air temperature sensor

Electric Heat

- Door interlocking disconnect switch
- Main fusing
- Silent relay/contactors

COILS, UNIT WEIGHTS

COILS

Titus® offers hot water, chilled water, direct expansion (DX), and standard steam coils for specific application with all THB Series Fan Coil Units.

STANDARD FEATURES

- Cooling - 2 to 6 row chilled water or 2 to 5 row DX
- Heating - 1 or 2 row hot water or steam
- 6 total rows of cooling and heating coils maximum
- Multiple circuiting options
- 10, 12 or 14 fins per inch
- High efficiency aluminum fin surface for optimizing heat transfer and pressure drop
- Left or right hand, same or opposite side connections
- Manual air vents

OPTIONAL FEATURES

- Automatic air vents
- Stainless steel coil casings
- DX coils are heat pump compatible

Titus offers selection software, the industry's first web-based fan coil rating and selection program for complete unit, coil and sound selection. Contact your representative for more information.

UNIT WEIGHT DATA

COMPONENT		UNIT SIZE							
		02	03	04	06	08	09	10	12
THBC BASE UNIT		22 [10]	25 [12]	33 [15]	43 [20]	53 [24]	60 [27]	74 [34]	83 [38]
THBP BASE UNIT		24 [11]	28 [13]	36 [16]	47 [21]	58 [26]	65 [30]	81 [37]	91 [41]
THBE BASE UNIT		56 [25]	63 [29]	75 [34]	92 [42]	108 [49]	118 [54]	141 [64]	158 [72]
COIL ROWS	1 ROW - DRY	6 [3]	7 [3]	8 [4]	10 [4]	11 [5]	13 [6]	15 [7]	17 [8]
	1 ROW - WET	8 [4]	9 [4]	10 [4]	12 [5]	13 [6]	15 [7]	17 [8]	19 [9]
	2 ROW - DRY	7 [3]	8 [4]	10 [4]	12 [5]	14 [6]	16 [7]	19 [9]	22 [10]
	2 ROW - WET	9 [4]	10 [5]	12 [5]	14 [6]	17 [8]	19 [8]	23 [10]	27 [12]
	3 ROW - DRY	8 [4]	10 [4]	12 [5]	14 [6]	17 [8]	19 [9]	23 [10]	26 [12]
	3 ROW - WET	10 [5]	12 [5]	15 [7]	17 [8]	21 [10]	23 [10]	28 [13]	32 [14]
	4 ROW - DRY	9 [4]	11 [5]	13 [6]	17 [8]	20 [9]	22 [10]	27 [12]	30 [14]
	4 ROW - WET	13 [6]	15 [7]	18 [8]	22 [10]	26 [12]	28 [13]	34 [15]	38 [17]
	5 ROW - DRY	11 [5]	13 [6]	15 [7]	19 [9]	23 [10]	25 [11]	30 [14]	35 [16]
	5 ROW - WET	17 [8]	19 [8]	22 [10]	26 [12]	31 [14]	33 [15]	39 [18]	45 [20]
	6 ROW - DRY	12 [5]	14 [6]	17 [8]	21 [10]	26 [12]	28 [13]	34 [16]	39 [18]
	6 ROW - WET	19 [9]	21 [10]	25 [11]	29 [13]	36 [16]	38 [17]	45 [21]	51 [23]

NOTE: Unit weight data is in pounds [kilograms].

RATINGS

AHRI STANDARD RATINGS

Model	Size	Coil		Airflow CFM (Dry flow)	Cooling Capacity		Water		Power Input (Watts)
		Rows	FPI		QT (BTUH)	QS (BTUH)	Flow Rate (GPM)	WPD (ft-wg)	
THBC	02	3 Rows	12	321	8860	6800	1.8	4.2	55
THBC	03	3 Rows	12	356	10820	7980	2.2	6.6	61
THBC	04	3 Rows	12	517	16820	12020	3.3	17.4	75
THBC	06	3 Rows	12	654	20710	14970	4.1	9.7	121
THBC	08	3 Rows	12	745	24700	17580	4.9	15.5	224
THBC	09	3 Rows	12	765	25340	18040	5.0	16.6	230
THBC	10	3 Rows	12	1166	36050	26100	7.2	18.0	226
THBC	12	3 Rows	12	1434	41210	30660	8.3	8.1	248
THBP	02	3 Rows	12	270	7780	5920	1.5	3.3	55
THBP	03	3 Rows	12	311	9690	7120	1.9	5.3	61
THBP	04	3 Rows	12	427	14740	10400	2.9	12.8	75
THBP	06	3 Rows	12	529	17680	12640	3.5	7.1	80
THBP	08	3 Rows	12	651	22610	15920	4.5	13.1	122
THBP	09	3 Rows	12	710	24090	17050	4.8	14.9	127
THBP	10	3 Rows	12	967	31890	22740	6.4	13.8	148
THBP	12	3 Rows	12	1075	33450	24470	6.7	5.0	160
THBE	02	3 Rows	12	252	7360	5590	1.5	2.9	55
THBE	03	3 Rows	12	287	9180	6700	1.8	4.8	61
THBE	04	3 Rows	12	399	14070	9880	2.8	12.2	75
THBE	06	3 Rows	12	485	16500	11750	3.3	6.2	80
THBE	08	3 Rows	12	602	21370	14980	4.3	11.7	122
THBE	09	3 Rows	12	682	23430	16540	4.6	14.0	127
THBE	10	3 Rows	12	893	30210	21420	6.0	12.3	148
THBE	12	3 Rows	12	992	35060	24540	7.0	19.6	160

NOTE: Based on 80°F DB and 67°F WB EAT, 45°F EWT, 10°F temperature rise, high fan speed. Motor type is PSC and motor voltage is 115/1/60. Airflow under dry coil conditions. Models THBE tested at 0.0" external static pressure. Models THBC and THBP tested at 0.05" external static pressure.

NOMINAL HEATING CAPACITY

Unit Size	Rows					
	1 Row			2 Rows		
	QS (MBH)	GPM	WPD	QS (MBH)	GPM	WPD
02	11.8	0.6	0.77	20.3	1	4.92
03	13.4	0.7	1.11	23.2	1.2	7.28
04	19.2	1	3.07	32.4	1.7	19.25
06	24.9	1.3	6.62	39.9	2	4.08
08	29.9	1.5	11.53	48.4	2.5	7.21
09	32.2	1.7	13.74	52.2	2.7	8.59
10	42.4	2.2	3.41	68.3	3.5	2.15
12	46.6	2.4	4.8	76.4	3.9	3.13

NOTE: Based on 70°F DB EAT, 180°F EWT, 40°F temperature drop, high fan speed.

ELECTRIC HEAT

Titus® offers electric heating coils with THB Fan Coil units. This allows the flexibility to provide an unrivaled amount of electric heat options in one complete package.

STANDARD FEATURES

- cETLus listed as an assembly for safety compliance
- Single point power connection
- Mounted in preheat position
- Automatic reset primary and back-up secondary thermal limits
- Internal wiring rated at 105°C
- Integral electric heat assembly with removable element for easy service
- Stainless steel terminals and hardware



USEFUL FORMULAS

$$\text{kW}^* = \frac{\text{CFM} \times \Delta T \times 1.085^{**}}{3413}$$

$$1\emptyset \text{ AMPs} = \frac{\text{kW} \times 1000}{\text{Volts}}$$

* 1kW = 3413 BTU/H

** Capacity at sea level

Altitude Considerations:

Reduce by 0.034 for each 1000 ft. of altitude above sea level.

Example: 5000 ft./1000 ft. = 5

$5 \times 0.034 = 0.17$

$1.085 - 0.17 = 0.915$

OPTIONAL FEATURES

- Silent solid state relays
- Manual reset secondary limits
- Door interlocking disconnect switch
- Main fusing (Branch fusing for EH>48 amps)

ELECTRICAL CALCULATIONS INFORMATION

1. Refer to MCA/MOP calculator at www.Titus.com for MCA and/or MOP calculations.
2. Non-Fused Door Interlock Disconnect Switch shall be sized according to MCA.
3. Fused Door Interlock Disconnect Switch and Main Fusing shall be sized according to MOP.

ELECTRIC HEAT

ELECTRIC HEAT SELECTION CHART (AMPS)

UNIT SIZE	MBH	3.4	5.1	6.8	10.2	13.6	17.1	20.5	23.9	27.3	30.7	34.1	40.9
	KW	1.0	1.5	2.0	3.0	4.0	5.0	6.0	7.0	8.0	9.0	10.0	12.0
	VOLTS	AMPS											
02	115	8.7	13.0	17.4									
	208	4.8	7.2	9.6									
	230	4.3	6.5	8.7									
	277	3.6	5.4	7.2									
03	115	8.7	13.0	17.4									
	208	4.8	7.2	9.6	14.4								
	230	4.3	6.5	8.7	13								
	277	3.6	5.4	7.2	10.8								
04	115	8.7	13.0	17.4	26.1								
	208	4.8	7.2	9.6	14.4								
	230	4.3	6.5	8.7	13								
	277	3.6	5.4	7.2	10.8								
06	115	8.7	13.0	17.4	26.1								
	208	4.8	7.2	9.6	14.4	19.2	24.0	28.8					
	230	4.3	6.5	8.7	13	17.4	21.7	26.1					
	277	3.6	5.4	7.2	10.8	14.4	18.1	21.7					
08	115	8.7	13.0	17.4	26.1								
	208	4.8	7.2	9.6	14.4	19.2	24.0	28.8	33.7				
	230	4.3	6.5	8.7	13	17.4	21.7	26.1	30.4				
	277	3.6	5.4	7.2	10.8	14.4	18.1	21.7	25.3				
09	115	8.7	13.0	17.4	26.1								
	208	4.8	7.2	9.6	14.4	19.2	24.0	28.8	33.7				
	230	4.3	6.5	8.7	13	17.4	21.7	26.1	30.4				
	277	3.6	5.4	7.2	10.8	14.4	18.1	21.7	25.3				
10	115	8.7	13.0	17.4	26.1								
	208	4.8	7.2	9.6	14.4	19.2	24.0	28.8	33.7	38.5			
	230	4.3	6.5	8.7	13	17.4	21.7	26.1	30.4	34.8			
	277	3.6	5.4	7.2	10.8	14.4	18.1	21.7	25.3	28.9			
12	115	8.7	13.0	17.4	26.1	34.8							
	208	4.8	7.2	9.6	14.4	19.2	24.0	28.8	33.7	38.5	43.3		
	230	4.3	6.5	8.7	13	17.4	21.7	26.1	30.4	34.8	39.1	43.5	
	277	3.6	5.4	7.2	10.8	14.4	18.1	21.7	25.3	28.9	32.5	36.1	43.3

NOTES:

1. Shaded areas of the electric heat selection chart indicate kW and voltage options not available.
2. Available voltages are single phase, 60 hertz.
3. Size heater for Leaving Air Temperature (LAT) less than 104°F.
4. Silent, solid state heater relay is available for sound sensitive environments.
5. Ask your Titus® representative about continuously modulating electric heat using SSR and special control options.
6. 70 CFM of airflow must be maintained per 1 KW of electric heat to prevent nuisance tripping of limit switches.

FAN PERFORMANCE CURVES (PSC Motors)

1. Fan curves on the following pages depict actual performance of each motor tap without any additional fan balance adjustment. Units should not be run prior to installation of downstream ductwork; otherwise, damage to the motor may result.
2. Titus Fan Coil Units are equipped with permanent split-capacitor (PSC) motors with three taps (High, Medium and Low) which provides variable horsepower outputs.
3. Fan curves include pressure losses for cabinet, a 3/8" 12 FPI 3 row coil, and a clean 1" throwaway filter. For other coil configurations, use Selection software* to generate performance curves.
4. See pages 13-14 for fan motor electrical data.
5. For additional high static pressure applications and rating points, use Selection software to generate performance curves.
6. For other models use Selection software to generate performance curves.

MODEL THBP

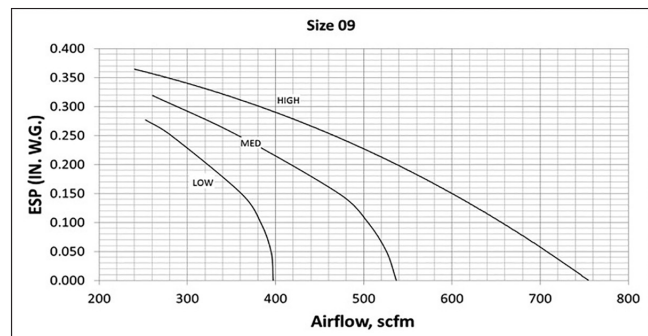
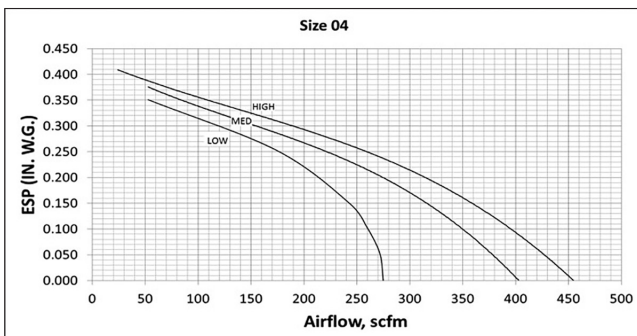
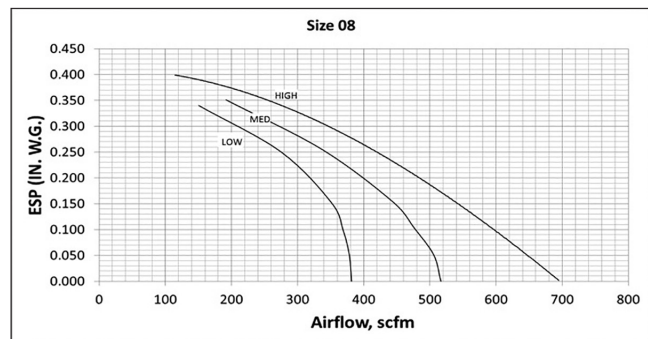
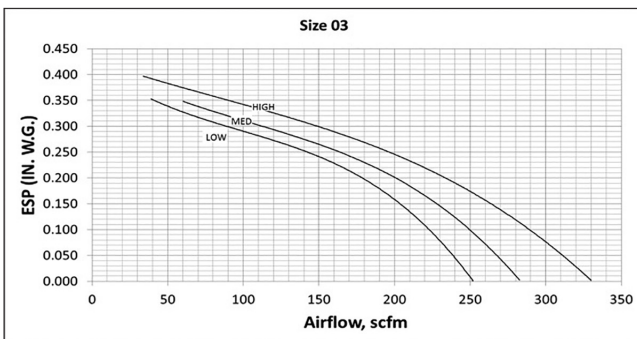
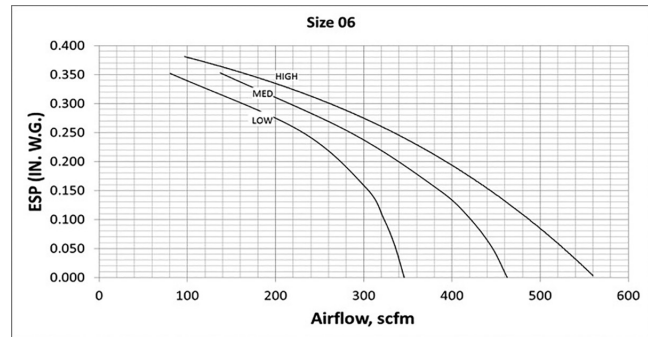
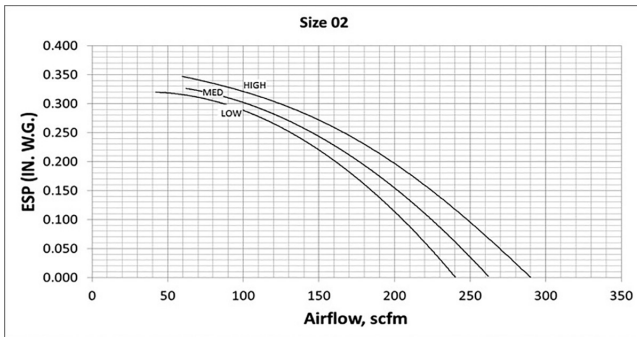

FAN PERFORMANCE CURVES (PSC Motors)

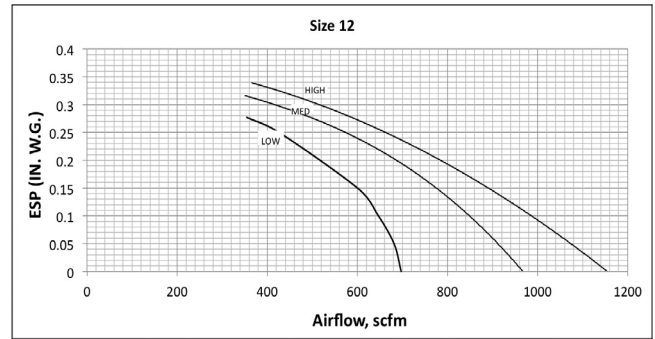
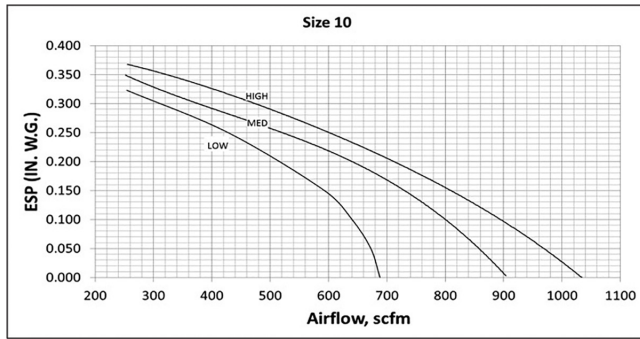

MOTOR, FAN AND SOUND DATA

PSC MOTORS, MODELS THBP AND THBE

UNIT SIZE	MOTOR HP (QTY)	# OF FANS	FAN SPEED	WATTS ²	115 VOLTS	208/230 VOLTS	277 VOLTS
					AMPS ¹	AMPS ¹	AMPS ¹
02	(1) 1/30 ³	1	High	55	0.5	N/A	N/A
			Medium	40			
			Low	36			
03	(1) 1/30 ³	1	High	61	0.5	N/A	N/A
			Medium	45			
			Low	40			
04	(1) 1/20	2	High	75	0.8	0.4	0.5
			Medium	65			
			Low	58			
06	(1) 1/20	2	High	80	0.8	0.4	0.5
			Medium	68			
			Low	56			
08	(1) 1/10	2	High	122	1.1	0.6	0.5
			Medium	83			
			Low	66			
09	(1) 1/10	2	High	127	1.1	0.6	0.5
			Medium	86			
			Low	66			
10	(2) 1/20	4	High	148	1.6	0.8	1
			Medium	128			
			Low	110			
12	(2) 1/20	4	High	160	1.6	0.8	1
			Medium	139			
			Low	115			

NOTES:

1. Motor electrical data is nameplate data.
2. Watts are based on an THBP with PSC motor, 3 row coil, 12FPI, 1" throwaway filter, 0.05" ESP at 115V.
3. PSC motors are not available in 208-277V on SZ02 and SZ03.
4. Motor data is subject to change and should not be used for submittal purposes. Refer to Selection software submittal for actual ratings.

MOTOR, FAN AND SOUND DATA

PSC MOTORS, MODEL THBC

UNIT SIZE	MOTOR HP (QTY)	# OF FANS	FAN SPEED	WATTS ²	115 VOLTS	208/230 VOLTS	277 VOLTS
					AMPS ¹	AMPS ¹	AMPS ¹
02	(1) 1/30 ³	1	High	55	0.5	N/A	N/A
			Medium	40			
			Low	36			
03	(1) 1/30 ³	1	High	61	0.5	N/A	N/A
			Medium	45			
			Low	40			
04	(1) 1/20	2	High	75	0.8	0.4	0.5
			Medium	65			
			Low	58			
06	(1) 1/10	2	High	121	1.1	0.6	0.5
			Medium	84			
			Low	66			
08	(1) 1/6	2	High	224	2.1	1.1	0.9
			Medium	140			
			Low	66			
09	(1) 1/6	2	High	230	2.1	1.1	0.9
			Medium	139			
			Low	67			
10	(2) 1/10	4	High	226	2.2	1.2	1
			Medium	154			
			Low	128			
12	(2) 1/10	4	High	248	2.2	1.2	1
			Medium	171			
			Low	133			

NOTES:

1. Motor electrical data is nameplate data.
2. Watts are based on an THBC with PSC motor, 3 row coil, 12FPI, 0.05" ESP at 115V.
3. PSC motors are not available in 208-277V on SZ02 and SZ03.
4. Motor data is subject to change and should not be used for submittal purposes. Refer to Selection software submittal for actual ratings.

FAN PERFORMANCE CURVES (EC MOTORS)

1. Fan curves on the following pages depict actual performance of each motor speed without any additional fan balance adjustment. Units should not be run prior to installation of downstream ductwork; otherwise, damage to the motor may result.
2. Fan curves shown are for the 3 speed EC motors with factory programmed high, medium and low speeds. For high static or variable speed EC options see Selection software[®] to generate performance curves.
3. Fan curves include pressure losses for cabinet, a 3/8" 12 FPI 3 row coil, and a clean 1" throwaway filter. For other coil configurations, use Selection software[®] to generate performance curves.
4. See page 16 for electrical data.
5. For other models use selection software to generate performance curves.

MODEL THBP

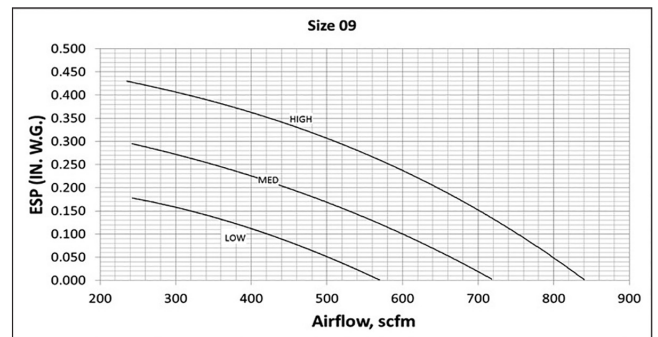
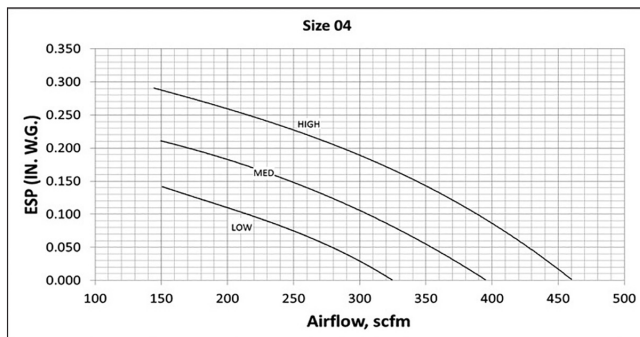
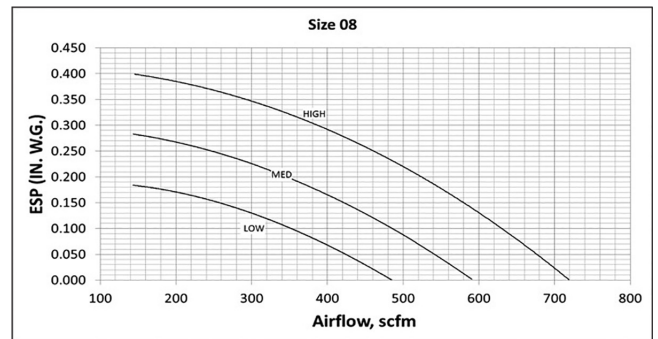
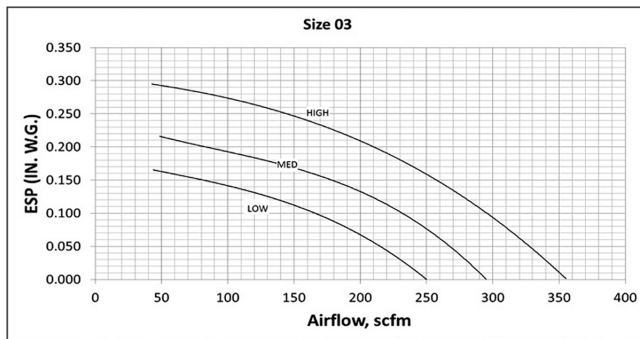
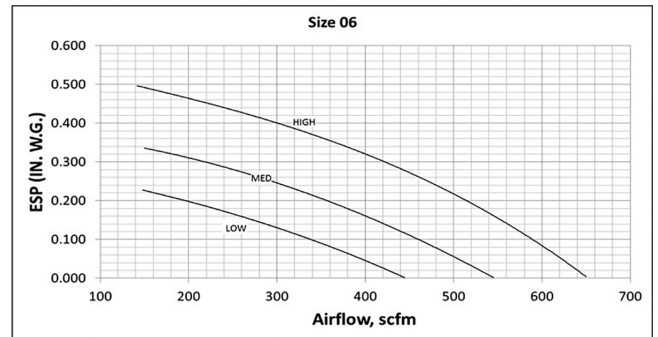
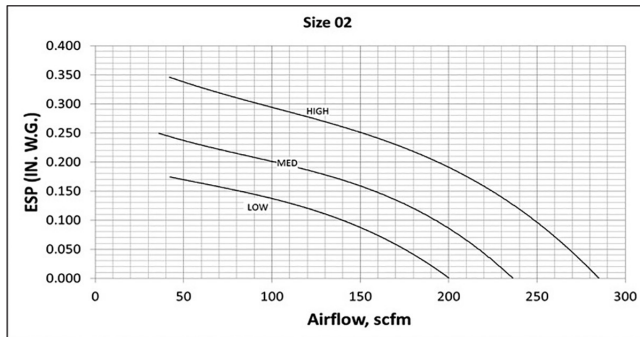

FAN PERFORMANCE CURVES (EC MOTORS)

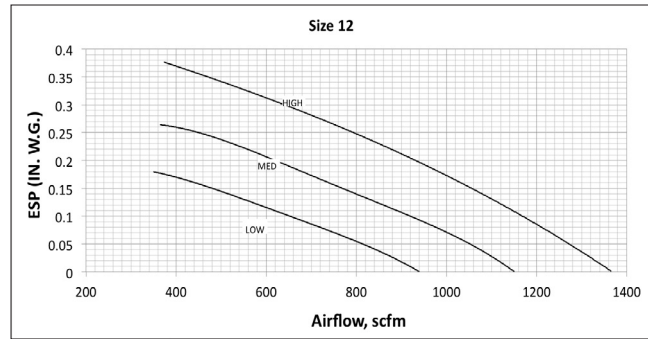
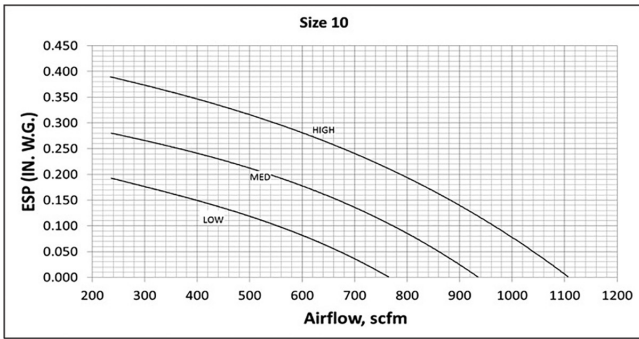

MOTOR, FAN AND SOUND DATA

EC MOTORS, MODELS THBP AND THBE

UNIT SIZE	MOTOR HP (QTY)	# OF FANS	FAN SPEED	WATTS ² (STD/HS)	AMPS ^{1,3}					
					115 VOLTS		208/230 VOLTS		277 VOLTS	
					3-SPEED (STD/HIGH STATIC)	2-10 VDC	3-SPEED (STD/ HIGH STATIC)	2-10 VDC	3-SPEED (STD/ HIGH STATIC)	2-10 VDC
02	(1) 1/4	1	High	32 / 45	0.7 / 1.0	0.9	0.5 / 0.6	0.5	0.4 / 0.5	0.5
			Medium	21 / 36						
			Low	14 / 26						
03	(1) 1/4	1	High	35 / 59	1.0 / 1.5	1.1	0.6 / 0.9	0.7	0.5 / 0.8	0.6
			Medium	23 / 43						
			Low	16 / 33						
04	(1) 1/4	2	High	50 / 75	1.5 / 1.8	1.2	0.9 / 1.1	0.8	0.8 / 0.9	0.6
			Medium	33 / 56						
			Low	21 / 41						
06	(1) 1/4	2	High	104 / 132	2.6 / 3.1	2.0	1.6 / 1.9	1.2	1.3 / 1.6	1.0
			Medium	62 / 89						
			Low	36 / 62						
08	(1) 1/4	2	High	91 / 122	2.3 / 2.9	2.0	1.4 / 1.7	1.2	1.2 / 1.5	1.0
			Medium	54 / 90						
			Low	31 / 62						
09	(1) 1/4	2	High	119 / 182	3.7 / 4.5	2.7	2.3 / 2.7	1.6	1.9 / 2.3	1.4
			Medium	72 / 116						
			Low	39 / 77						
10	(2) 1/4	4	High	142 / 207	3.9 / 5.1	3.1	2.3 / 3.1	1.9	2.0 / 2.6	1.6
			Medium	91 / 139						
			Low	54 / 104						
12	(2) 1/4	4	High	143 / 209	3.2 / 4.5	3.5	2.0 / 2.7	2.1	1.6 / 2.3	1.8
			Medium	92 / 152						
			Low	56 / 105						

NOTES:

1. Motor electrical data is nameplate data.
2. Watts are based on an THBP with 3-speed EC motor, 3 row coil, 12FPI, 1" throwaway filter, 0.05" ESP at 115V.
3. For three phase neutral conductor sizing, multiply AMPS by 1.73.
4. Motor data is subject to change and should not be used for submittal purposes. Refer to Selection software submittal for actual ratings.

SOUND DATA

MODEL THBP - AHRI 260 DUCTED DISCHARGE

UNIT SIZE	FAN SPEED	SCFM	SOUND POWER LEVEL						
			OCTAVE BAND/CENTER FREQUENCY (HZ)						
			2/125	3/250	4/500	5/1000	6/2000	7/4000	8/8000
02	High	270	55	54	49	49	45	40	32
	Medium	245	54	51	47	46	41	35	28
	Low	223	52	49	44	44	39	32	26
03	High	311	55	54	49	49	45	40	32
	Medium	268	54	51	47	46	41	35	28
	Low	237	52	49	44	44	39	32	26
04	High	425	55	53	50	50	47	41	33
	Medium	377	53	50	47	47	44	37	30
	Low	272	49	44	42	40	37	31	27
06	High	529	55	53	50	50	47	41	33
	Medium	448	53	50	47	47	44	37	30
	Low	335	49	44	42	40	37	31	27
08	High	650	58	58	55	55	52	46	38
	Medium	506	51	50	48	47	43	34	27
	Low	378	47	44	43	40	34	24	24
09	High	709	58	58	55	55	52	46	38
	Medium	525	51	50	48	47	43	34	27
	Low	395	47	44	43	40	34	24	24
10	High	967	59	58	56	56	52	47	39
	Medium	863	52	51	49	47	43	35	28
	Low	672	47	45	43	40	34	25	25
12	High	1083	59	59	56	56	53	47	39
	Medium	912	52	51	49	48	44	35	28
	Low	681	48	45	44	41	35	25	25

NOTES:

1. Sound data tested in accordance with AHRI 260-2012.
2. Sound levels are expressed in decibels, dB RE: 1 x 10⁻¹² watts.
3. Sound power level data based on Model THBP with fan CFM at corresponding motor tap with 115/1/60 volt PSC motor, 3 row coil, 1" throwaway filter, 0.05" external static pressure and standard rated internal pressure losses.
4. No duct end correction

SOUND DATA

MODEL THBP - AHRI 260 CASING RADIATED FREE INLET

UNIT SIZE	FAN SPEED	SCFM	SOUND POWER LEVEL						
			OCTAVE BAND/CENTER FREQUENCY (HZ)						
			2/125	3/250	4/500	5/1000	6/2000	7/4000	8/8000
02	High	270	55	57	53	49	42	37	32
	Medium	245	56	54	52	47	40	34	29
	Low	223	56	53	50	45	38	32	27
03	High	311	55	57	53	49	42	37	32
	Medium	268	56	54	52	47	40	34	29
	Low	237	56	53	50	45	38	32	27
04	High	425	57	59	57	53	46	41	34
	Medium	377	55	57	55	50	43	38	31
	Low	272	52	53	51	45	39	33	28
06	High	529	57	59	57	53	46	41	34
	Medium	448	55	57	55	50	43	38	31
	Low	335	52	53	51	45	39	33	28
08	High	650	61	62	58	54	47	43	36
	Medium	506	55	56	53	47	40	34	27
	Low	378	51	51	48	41	32	26	24
09	High	709	61	62	58	54	47	43	36
	Medium	525	55	56	53	47	40	34	27
	Low	395	51	51	48	41	32	26	24
10	High	967	58	57	57	54	46	40	32
	Medium	863	57	54	55	51	44	37	29
	Low	672	54	50	51	46	38	29	26
12	High	1083	58	57	57	54	46	40	32
	Medium	912	57	54	55	51	44	37	29
	Low	681	54	50	51	46	38	29	26

NOTES:

1. Sound data tested in accordance with AHRI 260-2012.
2. Sound levels are expressed in decibels, dB RE: 1 x 10⁻¹² watts.
3. Sound power level data based on Model THBP with fan CFM at corresponding motor tap with 115/1/60 volt PSC motor, 3 row coil, 1" throwaway filter, 0.05" external static pressure and standard rated internal pressure losses.

SOUND DATA

MODEL THBE - AHRI 350

UNIT SIZE	FAN SPEED	SCFM	TOTAL SOUND POWER LEVEL						
			OCTAVE BAND / CENTER FREQUENCY (HZ)						
			2/125	3/250	4/500	5/1000	6/2000	7/4000	8/8000
02	High	252	53	58	53	51	45	39	31
	Medium	232	52	56	52	49	43	36	29
	Low	214	51	54	51	47	41	33	26
03	High	287	53	58	53	51	45	39	31
	Medium	254	52	56	52	49	43	36	29
	Low	224	51	54	51	47	41	33	26
04	High	399	56	60	57	54	49	43	34
	Medium	358	56	57	55	52	46	38	29
	Low	269	52	52	50	45	38	28	24
06	High	485	56	60	57	54	49	43	34
	Medium	426	56	57	55	52	46	38	29
	Low	320	52	52	50	45	38	28	24
08	High	602	61	62	59	57	52	48	40
	Medium	491	55	56	54	50	45	39	31
	Low	377	49	50	47	43	36	28	25
09	High	682	61	62	59	57	52	48	40
	Medium	558	55	56	54	50	45	39	31
	Low	416	49	50	47	43	36	28	25
10	High	893	57	60	59	57	50	43	35
	Medium	812	58	58	57	54	48	40	32
	Low	658	55	53	53	49	41	32	26
12	High	992	57	60	59	57	50	43	35
	Medium	870	58	58	57	54	48	40	32
	Low	672	55	53	53	49	41	32	26

NOTES:

1. Sound data tested in accordance with AHRI 350-2015.
2. Sound levels are expressed in decibels, dB RE: 1 x 10⁻¹² watts.
3. Total sound power level data based on Model THBE with fan CFM at corresponding motor tap with 115/1/60 volt PSC motor, 3 row coil, 1" throwaway filter, 0.0" external static pressure and standard rated internal pressure losses.

DIMENSIONAL DATA

MODEL THBP & THBC EXTERNAL FEATURE SPACE REQUIREMENTS

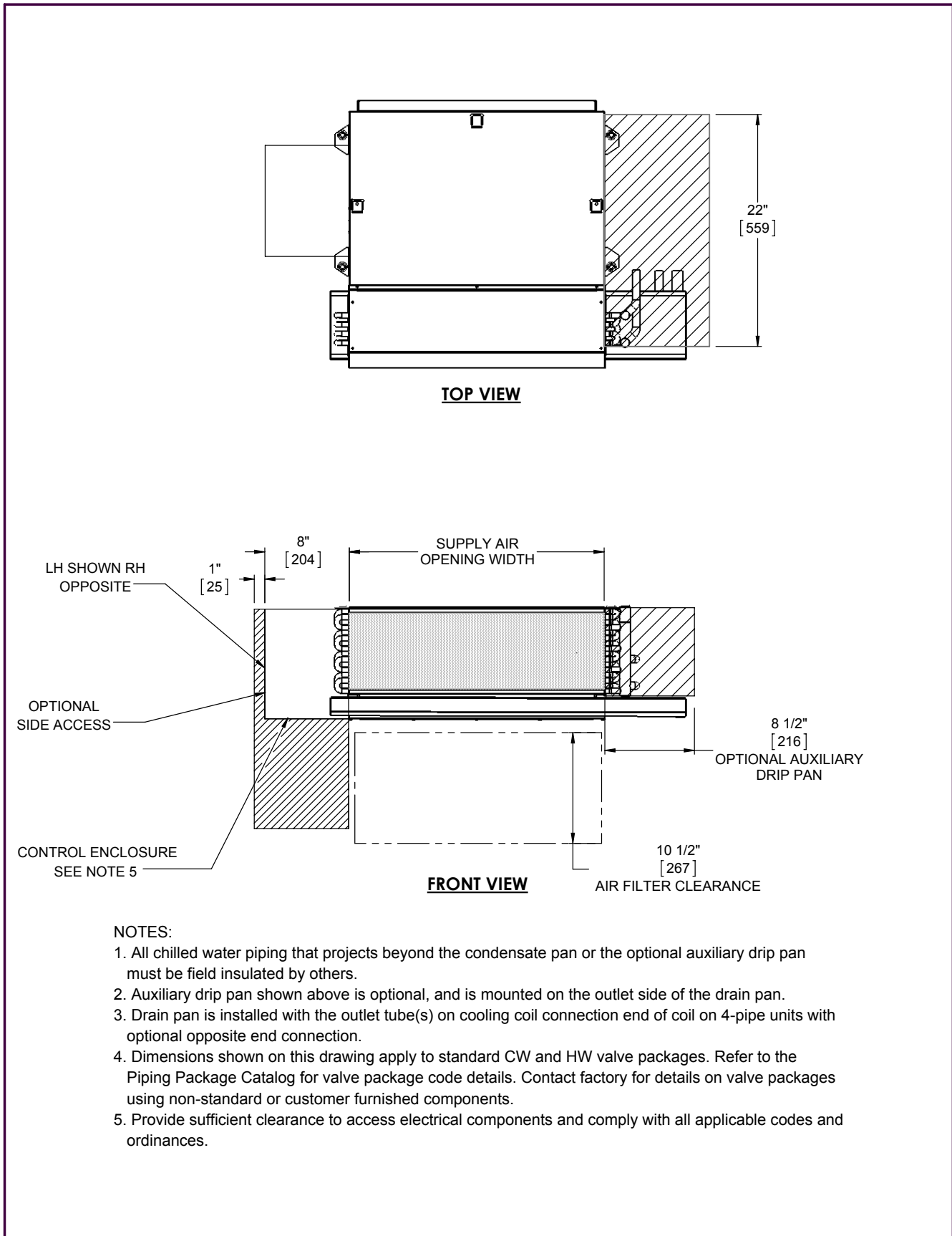

DIMENSIONAL DATA

MODEL THBC WITH COOLING AND ELECTRIC HEAT

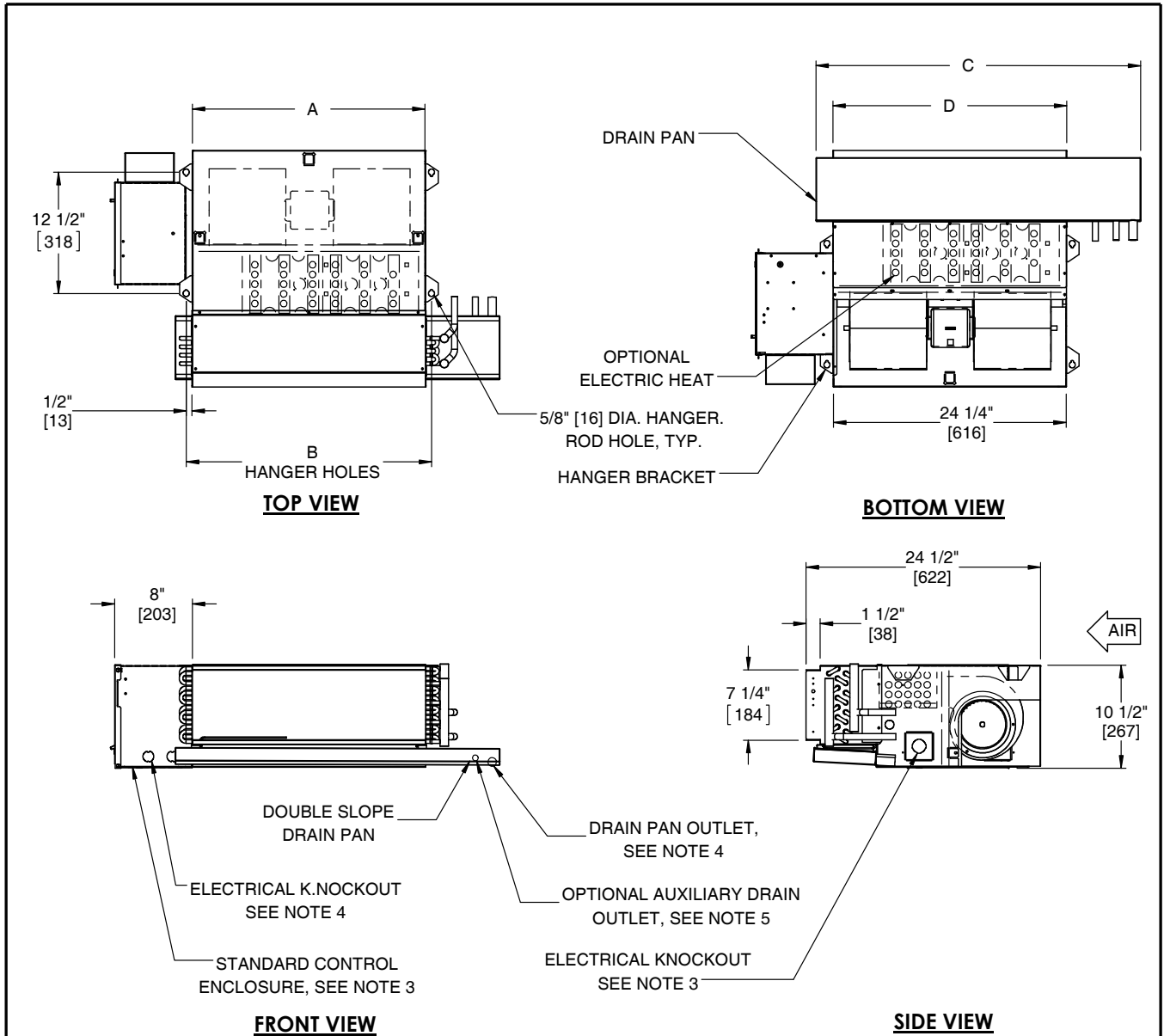

DIMENSIONS				
UNIT SIZE	A	B	C	D
02	16" [406]	17 1/4" [438]	25 1/4" [641]	16" [406]
03	19 1/4" [489]	20 1/2" [521]	28 1/2" [724]	19 1/4" [489]
04	24 1/4" [616]	25 1/2" [648]	33 1/2" [851]	24 1/4" [616]
06	31" [787]	32 1/4" [819]	40 1/4" [1022]	31" [787]
08	38" [965]	39 1/4" [997]	47 1/4" [1200]	38" [965]
09	42 1/4" [1073]	43 1/2" [1105]	51 1/2" [1308]	42 1/4" [1073]
10	52" [1321]	53 1/4" [1353]	61 1/4" [1556]	52" [1321]
12	60" [1524]	61 1/4" [1556]	69 1/4" [1759]	60" [1524]

NOTES:

- All dimensions in Inches [millimeters]. All dimensions ±1/4" [6mm]. Metric values are soft conversion.
- Left hand unit shown, right hand unit opposite.
- Standard control enclosure is mounted on unit side opposite cooling coil connections. Unit casing includes (2) knockouts on one side and (1) knockout on another side. Provide sufficient clearance to access electrical controls and comply with applicable codes and ordinances.
- Standard externally foam coated galvanized steel drain pan has 7/8" ODM copper outlet. Stainless steel drain pan has 3/4" MPT galvanized steel outlet.
- Standard galvanized steel aux. drain pan has 5/8" ODM copper outlet. Stainless steel aux. drain pan has 3/4" MPT galvanized steel outlet.
- See coil connection drawings for coil connection sizes and locations.

DIMENSIONAL DATA

MODEL THBC WITH ELECTRIC HEAT

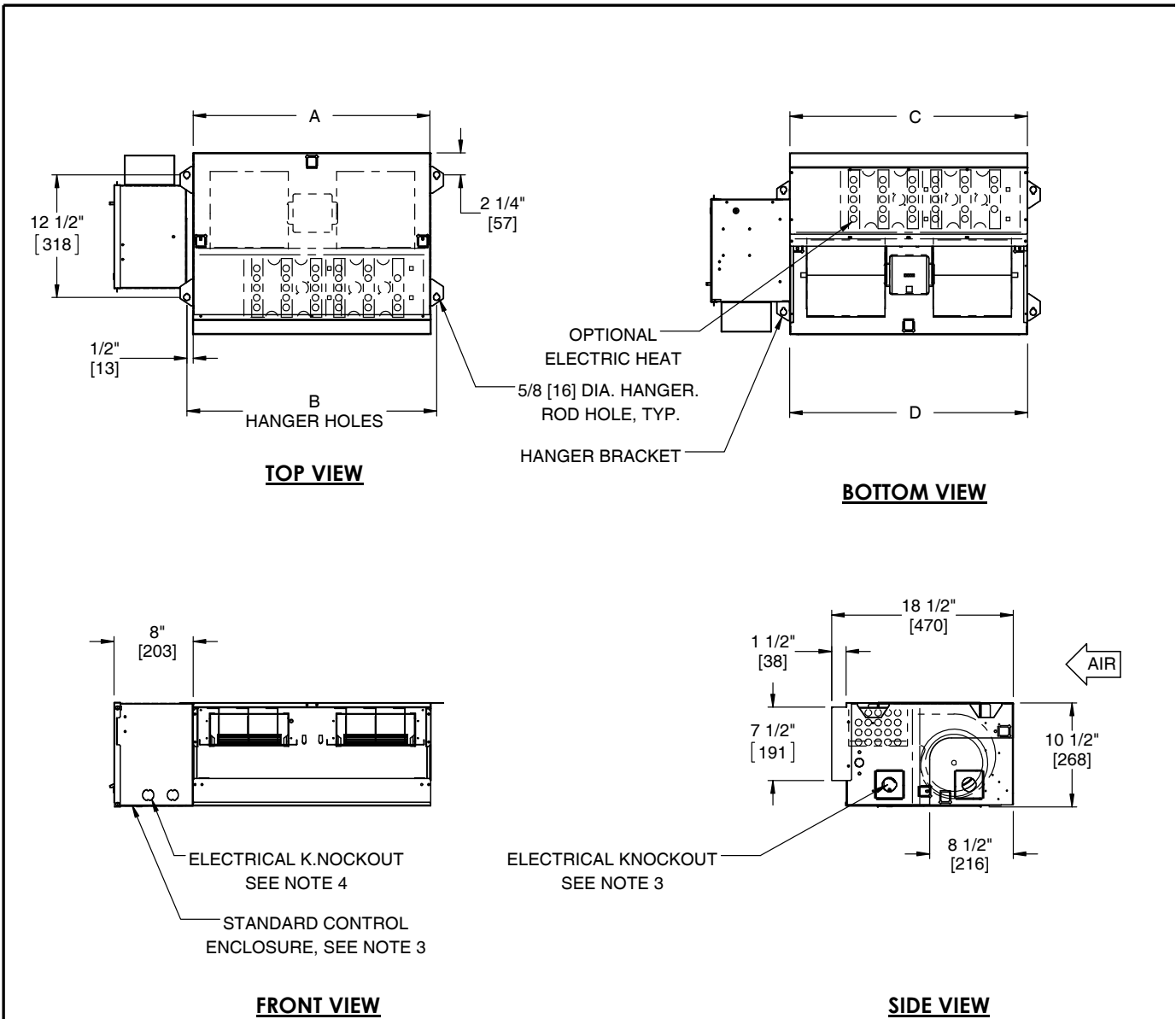

DIMENSIONS				
UNIT SIZE	A	B	C	D
02	16 [406]	17 1/4" [438]	16 [406]	13 3/16" [335]
03	19 1/4" [489]	20 1/2" [521]	19 1/4" [489]	16 7/16" [418]
04	24 1/4" [616]	25 7/16" [646]	24 1/4" [616]	22 11/16" [576]
06	31 [787]	32 1/4" [819]	31 [787]	29 7/16" [748]
08	38 [965]	39 1/4" [997]	38 [965]	36 7/16" [926]
09	42 1/4" [1073]	43 5/16" [1100]	42 1/4" [1073]	40 1/2" [1029]
10	52 [1321]	53 1/4" [1353]	52 [1321]	50 7/16" [1281]

NOTES:

1. All dimensions in Inches [millimeters]. All dimensions $\pm 1/4"$ [6mm]. Metric values are soft conversion.
2. Left hand unit shown, right hand unit opposite.
3. Standard control enclosure is mounted on unit side opposite cooling coil connections. Unit casing includes (2) knockouts on each side. Provide sufficient clearance to access electrical controls and comply with applicable codes and ordinances.

DIMENSIONAL DATA

MODEL THBP WITH ELECTRIC HEAT

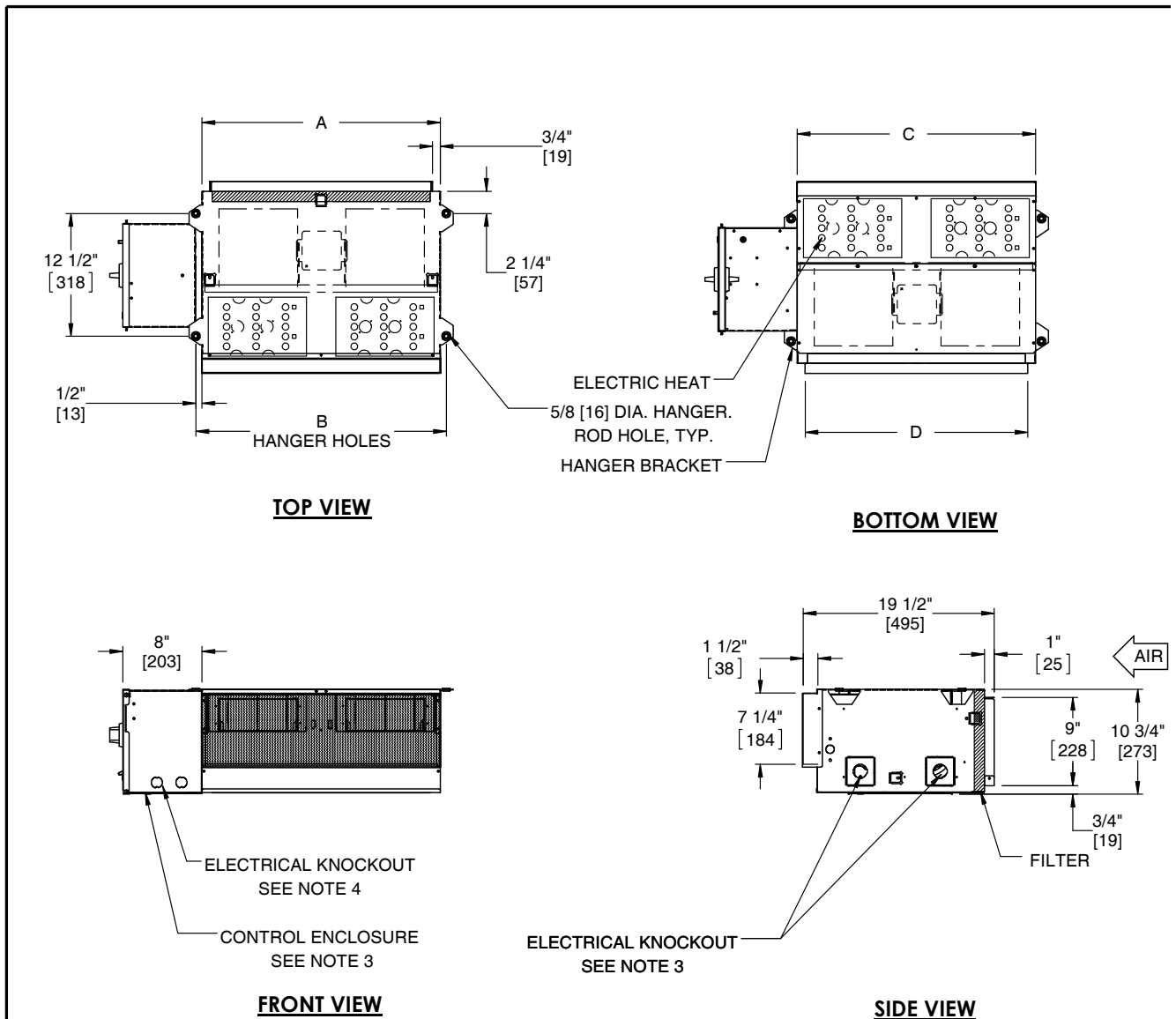

DIMENSIONS				
UNIT SIZE	A	B	C	D
02	16" [406]	17 1/4" [438]	16" [406]	13 3/16" [335]
03	19 1/4" [489]	20 1/2" [521]	19 1/4" [489]	16 7/16" [418]
04	24 1/4" [616]	25 7/16" [646]	24 1/4" [616]	22 11/16" [576]
06	31" [787]	32 1/4" [819]	31" [787]	29 7/16" [748]
08	38" [965]	39 1/4" [997]	38" [965]	36 7/16" [925]
09	42 1/4" [1073]	43 5/16" [1100]	42 1/4" [1073]	40 1/2" [1029]
10	52" [1321]	53 1/4" [1353]	52" [1321]	50 7/16" [1281]

- NOTES:**
1. All dimensions in Inches [millimeters]. All dimensions $\pm 1/4"$ [6mm]. Metric values are soft conversion.
 2. Left hand unit shown, right hand unit opposite.
 3. Standard control enclosure is mounted on unit side opposite cooling coil connections. Unit casing includes (2) knockouts on each side. Provide sufficient clearance to access electrical controls and comply with applicable codes and ordinances.

DIMENSIONAL DATA

MODEL THBP WITH ELECTRIC HEAT - COOLING AND HEATING

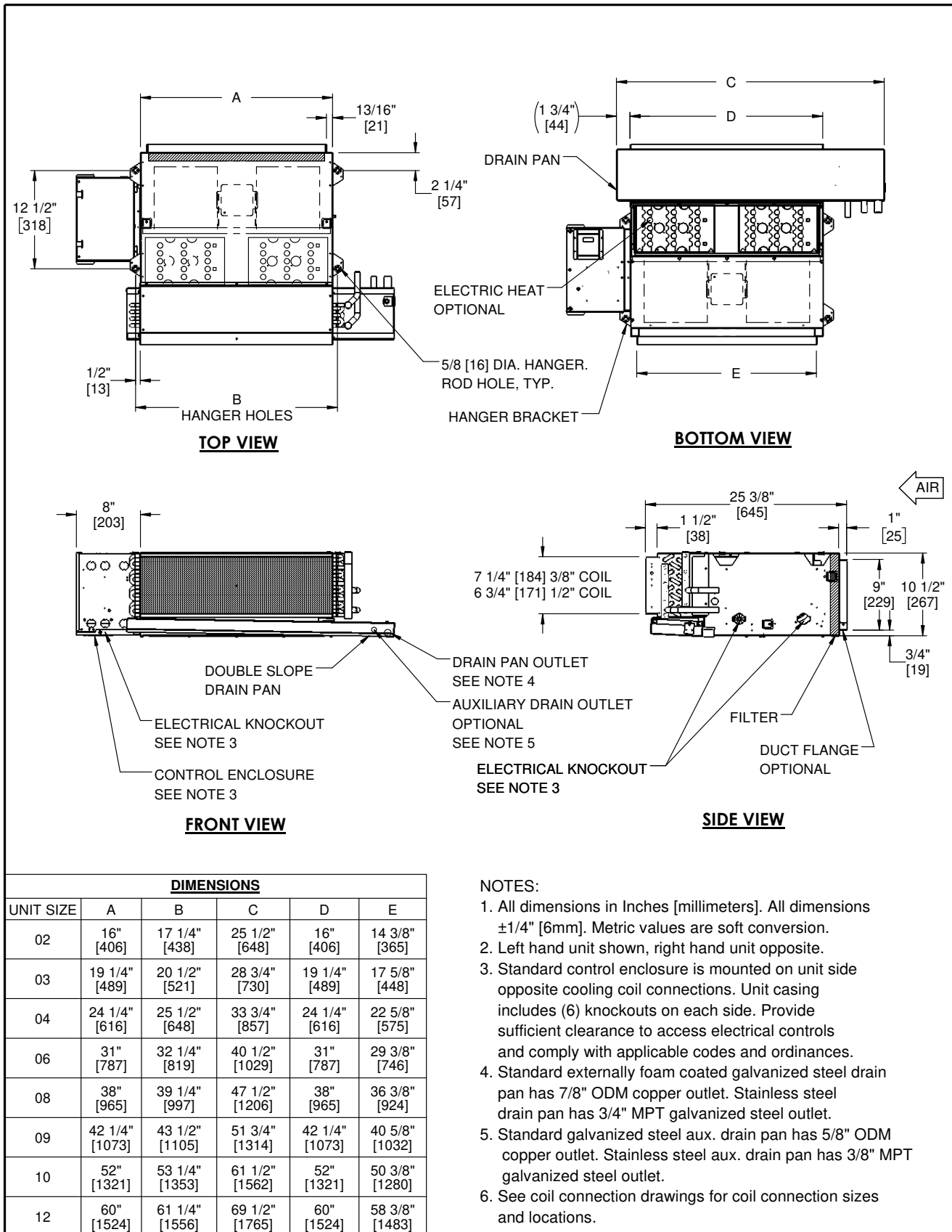

DIMENSIONAL DATA

MODEL THBP BOTTOM RETURN WITH OPTIONAL ELECTRIC HEAT

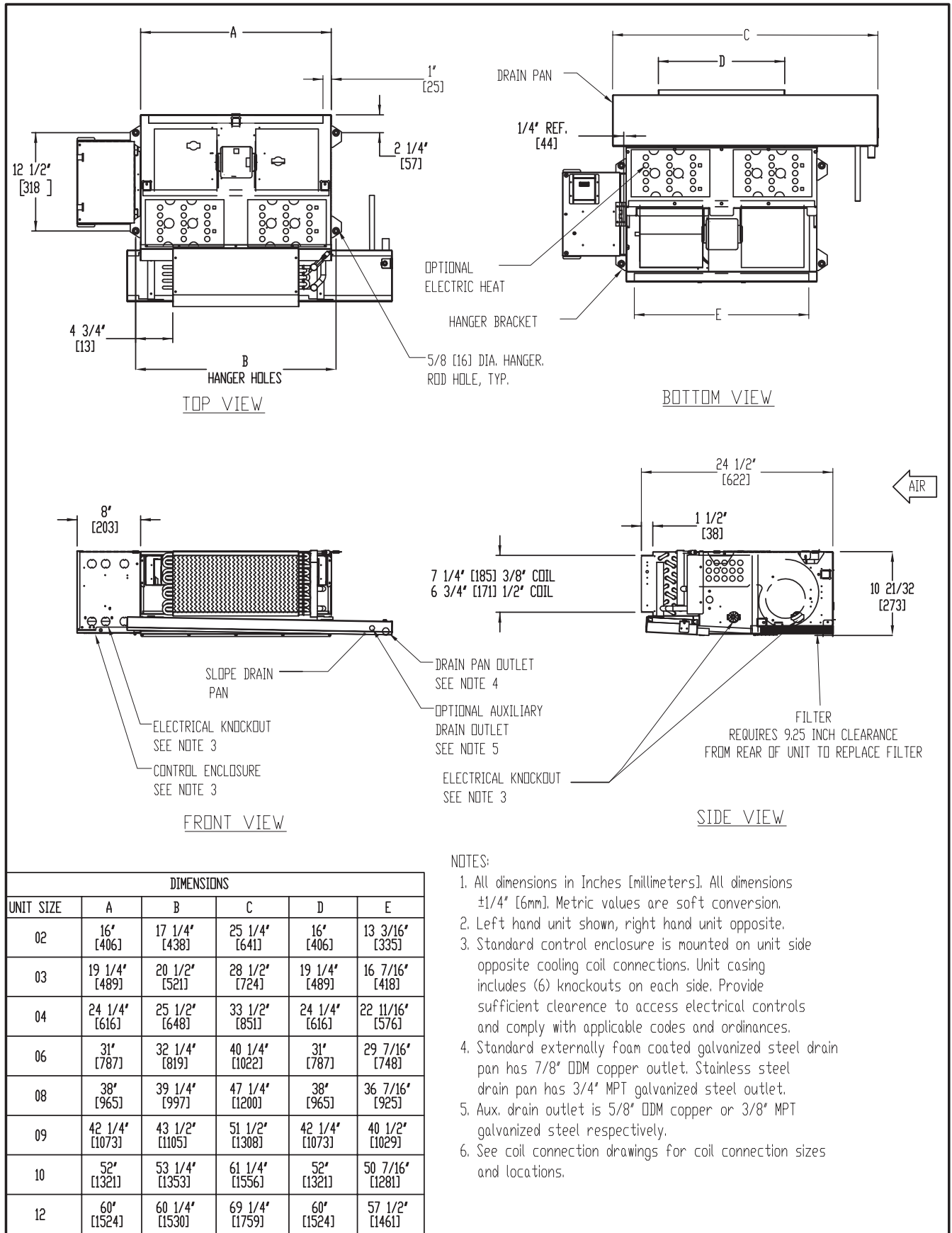

NOTES:

1. All dimensions in Inches [millimeters]. All dimensions $\pm 1/4"$ [6mm]. Metric values are soft conversion.
2. Left hand unit shown, right hand unit opposite.
3. Standard control enclosure is mounted on unit side opposite cooling coil connections. Unit casing includes (6) knockouts on each side. Provide sufficient clearance to access electrical controls and comply with applicable codes and ordinances.
4. Standard externally foam coated galvanized steel drain pan has 7/8" ODM copper outlet. Stainless steel drain pan has 3/4" MPT galvanized steel outlet.
5. Aux. drain outlet is 5/8" ODM copper or 3/8" MPT galvanized steel respectively.
6. See coil connection drawings for coil connection sizes and locations.

DIMENSIONAL DATA

MODEL THBP TELESCOPING BOTTOM PANEL

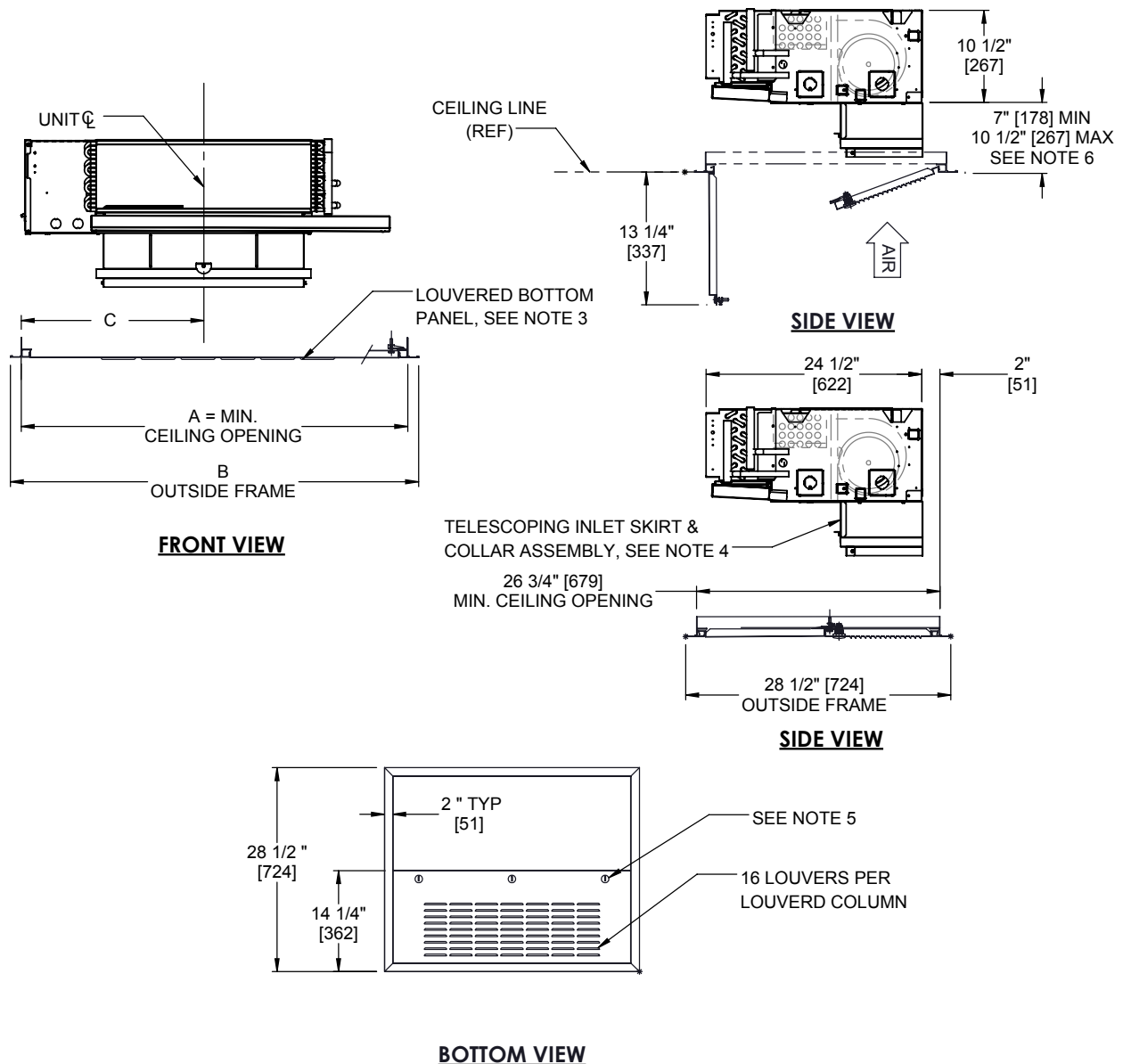

DIMENSIONS			
UNIT SIZE	A	B	C
02	38 1/4" [972]	40 1/4" [1022]	19 1/8" [486]
03	41 1/2" [1054]	43 1/2" [1105]	20 3/4" [527]
04	46 1/2" [1181]	48 1/2" [1232]	23 1/4" [591]
06	53 1/4" [1353]	55 1/4" [1403]	26 5/8" [676]
08	60 1/4" [1530]	62 1/4" [1581]	30 1/8" [765]
09	64 1/2" [1638]	66 1/2" [1689]	32 1/4" [819]
10	74 1/4" [1885]	76 1/4" [1937]	37 1/8" [943]
12	82 1/4" [2089]	84 1/4" [2140]	41 1/8" [1045]

NOTES:

1. All dimensions in Inches [millimeters]. All dimensions ±1/4" [6mm]. Metric values are soft conversion.
2. Left hand unit shown, right hand unit opposite.
3. Portions of the inlet louver not directly below unit inlet may require covering in the field on applications where infiltration of ceiling plenum air into space is undesired.
4. Telescoping skirt and collar assembly must be field adjusted to assure a proper fit between filter frame and louvered inlet panel assembly.
5. 1/4 Turn latch, (2) qty for standard sizes, (3) qty for sizes 10-12.
6. Please reference the external feature space requirements submittal for complete service space requirements. Service access may be limited based on the panels are installed in relation to the unit.

DIMENSIONAL DATA

MODEL THBP AND THBC SOLID BOTTOM ACCESS PANEL

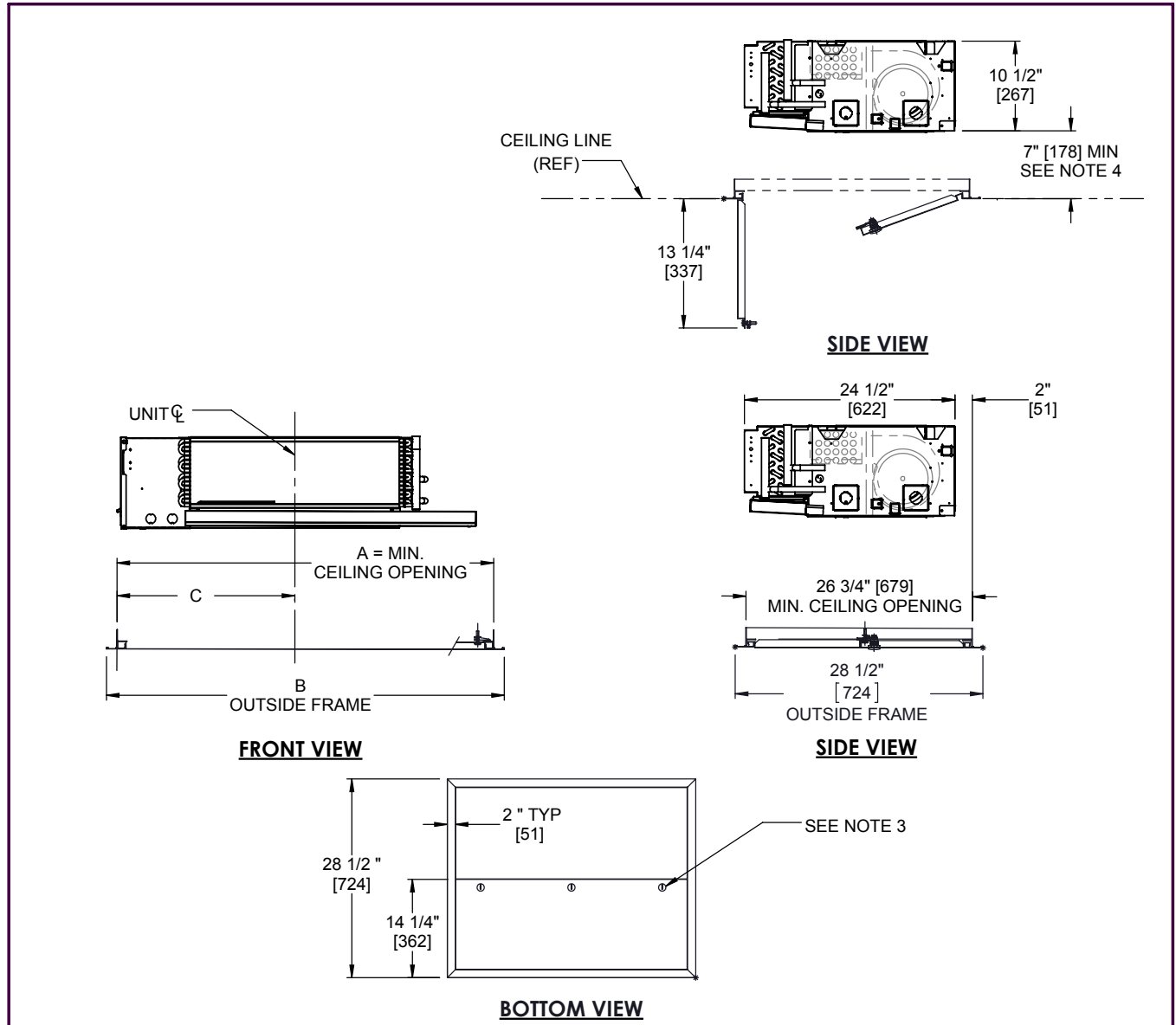

DIMENSIONS			
UNIT SIZE	A	B	C
02	38 1/4" [972]	40 1/4" [1022]	19 1/8" [486]
03	41 1/2" [1054]	43 1/2" [1105]	20 3/4" [527]
04	46 1/2" [1181]	48 1/2" [1232]	23 1/4" [591]
06	53 1/4" [1353]	55 1/4" [1403]	26 5/8" [676]
08	60 1/4" [1530]	62 1/4" [1581]	30 1/8" [765]
09	64 1/2" [1638]	66 1/2" [1689]	32 1/4" [819]
10	74 1/4" [1885]	76 1/4" [1937]	37 1/8" [943]
12	82 1/4" [2089]	84 1/4" [2140]	41 1/8" [1045]

NOTES:

1. All dimensions in Inches [millimeters]. All dimensions ±1/4" [6mm]. Metric values are soft conversion.
2. Left hand unit shown, right hand unit opposite.
3. 1/4 Turn latch, (2) qty for standard sizes, (3) qty for sizes 10-12.
4. Please reference the external feature space requirements submittal for complete service space requirements. Service access may be limited based on the panels are installed in relation to the unit.

DIMENSIONAL DATA

MODEL THBE REAR RETURN

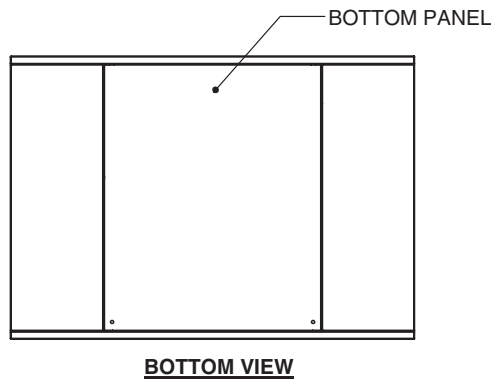
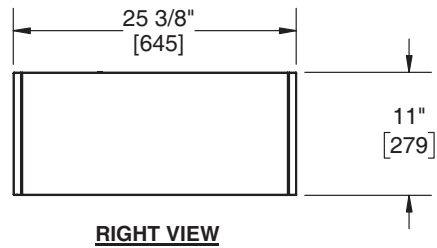
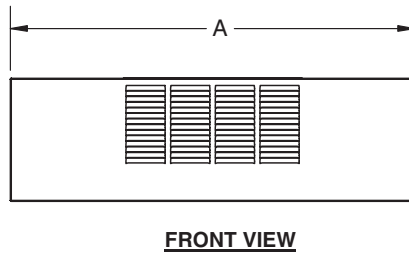
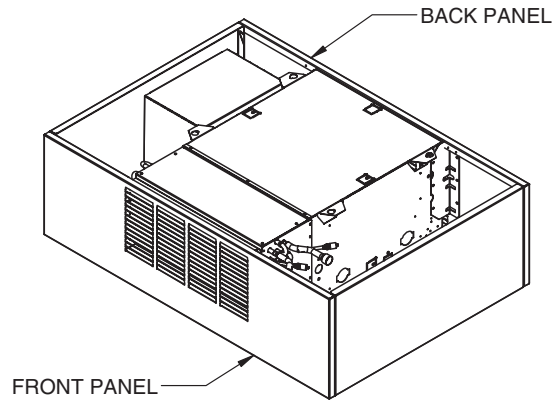
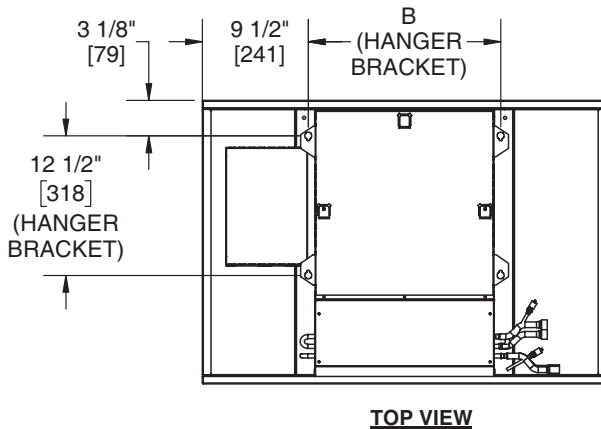

DIMENSIONS		
UNIT SIZE	A	B
02	36 1/4" [921]	17 1/4" [438]
03	39 1/2" [1003]	20 1/2" [521]
04	44 1/2" [1130]	25 1/2" [648]
06	51 1/4" [1302]	32 1/4" [819]
08	58 1/4" [1480]	39 1/4" [997]
09	62 1/2" [1588]	43 1/2" [1105]
10	72 1/4" [1835]	53 1/4" [1353]
12	80 1/4" [2038]	61 1/4" [1556]

NOTES:

1. All dimensions are inches [millimeters]. All dimensions $\pm 1/4"$ [6mm]. Metric values are soft conversions.
2. Left hand unit shown, right hand unit opposite.
3. Provide sufficient clearance to access electrical controls and comply with applicable codes and ordinances.
4. Drain piping should be routed through casing opening indicated to provide proper slope.
5. Bottom panel removable for access to filter and fan assembly.
6. Corner panels are removable to access electrical enclosure, coil and valve pack.
7. Internal insulation of field piping may be required.
8. Field piping casing penetrations must be cut in the field to match individual job requirements.
9. All dimensions also apply to units with Electric Heat Only.

DIMENSIONAL DATA

MODEL THBE REAR RETURN (CONT'D)

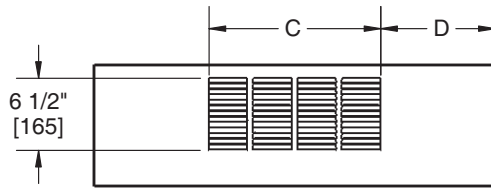

FRONT PANEL LOUVERED SUPPLY

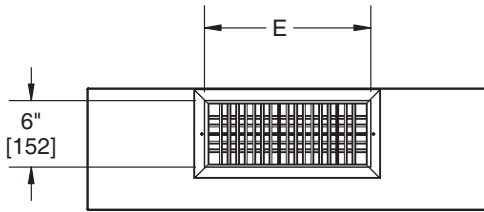

FRONT PANEL DUCTED SUPPLY

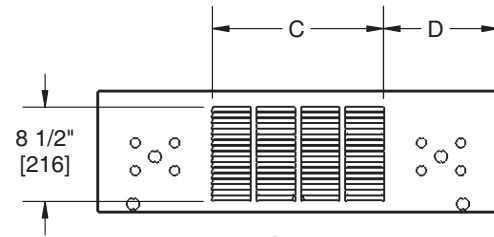
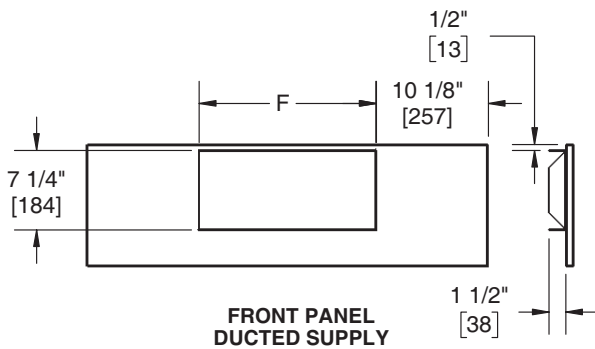

BACK PANEL LOUVERED RETURN

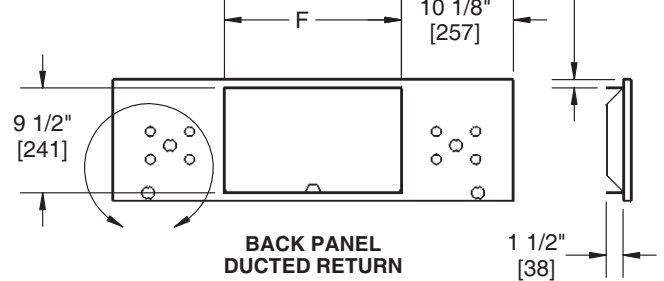

BACK PANEL DUCTED RETURN

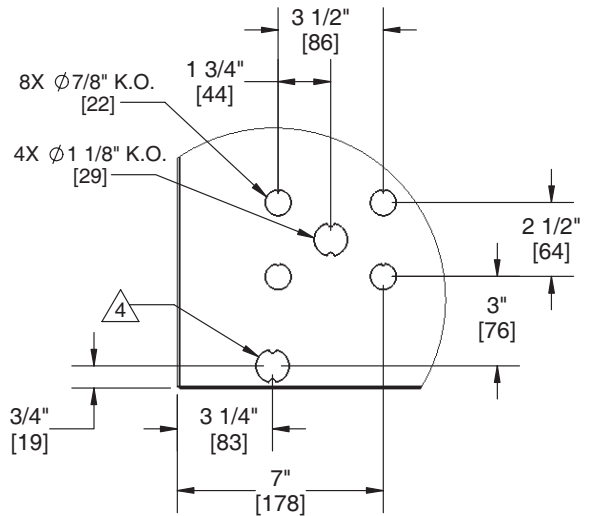

DETAIL G

DIMENSIONS				
UNIT SIZE	C	D	E	F
02	15 1/2" [394]	10 3/8" [264]	15" [381]	16" [406]
03	15 1/2" [394]	12" [305]	18" [457]	19 1/4" [489]
04	23 1/2" [597]	10 1/2" [267]	23" [584]	24 1/4" [616]
06	27 1/2" [699]	11 7/8" [302]	30" [762]	31" [787]
08	35 1/2" [902]	11 3/8" [289]	37" [940]	38" [965]
09	39 1/2" [1003]	11 1/2" [292]	41" [1041]	42 1/4" [1073]
10	51 1/2" [1308]	10 3/8" [264]	23" [584]	52" [1321]
12	59 1/2" [1511]	10 3/8" [264]	27" [686]	60" [1524]

NOTES:

1. All dimensions are inches [millimeters]. All dimensions $\pm 1/4"$ [6mm]. Metric values are soft conversions.
2. Left hand unit shown, right hand unit opposite.
3. Provide sufficient clearance to access electrical controls and comply with applicable codes and ordinances.
4. Drain piping should be routed through casing opening indicated to provide proper slope.
5. Bottom panel removable for access to filter and fan assembly.
6. Corner panels are removable to access electrical enclosure, coil and valve pack.
7. Internal insulation of field piping may be required.
8. Field piping casing penetrations must be cut in the field to match individual job requirements.
9. All dimensions also apply to units with Electric Heat Only.

DIMENSIONAL DATA

MODEL THBE BOTTOM RETURN

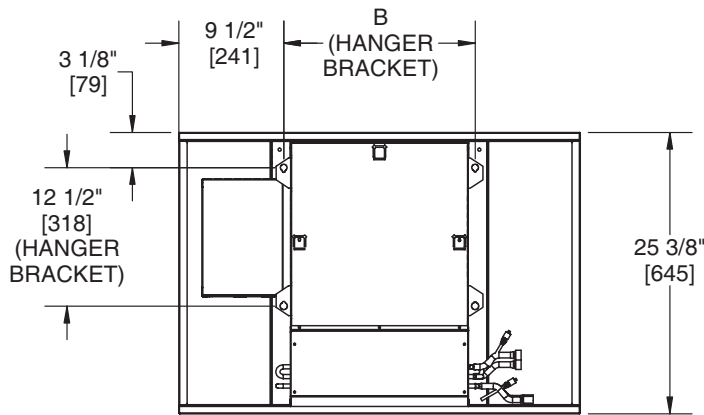

TOP VIEW

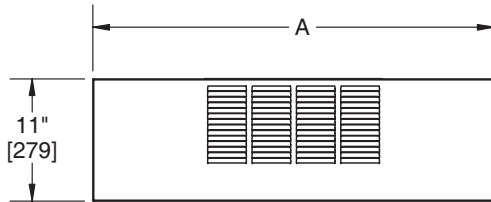
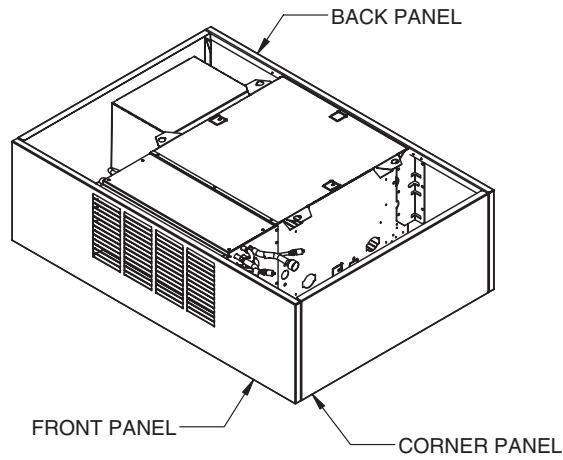

FRONT VIEW



RIGHT VIEW

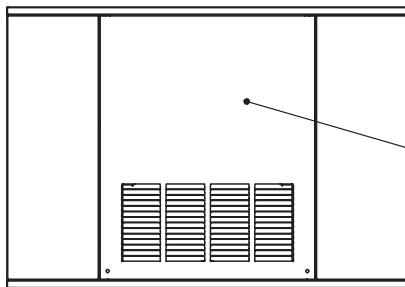

BOTTOM VIEW

DIMENSIONS		
UNIT SIZE	A	B
02	36 1/4" [921]	17 1/4" [438]
03	39 1/2" [1003]	20 1/2" [521]
04	44 1/2" [1130]	25 1/2" [648]
06	51 1/4" [1302]	32 1/4" [819]
08	58 1/4" [1480]	39 1/4" [997]
09	62 1/2" [1588]	43 1/2" [1105]
10	72 1/4" [1835]	53 1/4" [1353]
12	80 1/4" [2038]	61 1/4" [1556]

NOTES:

1. All dimensions are inches [millimeters]. All dimensions $\pm 1/4"$ [6mm]. Metric values are soft conversions.
2. Left hand unit shown, right hand unit opposite.
3. Provide sufficient clearance to access electrical controls and comply with applicable codes and ordinances.
4. Drain piping should be routed through casing opening indicated to provide proper slope.
5. Bottom panel removable for access to filter and fan assembly.
6. Corner panels are removable to access electrical enclosure, coil and valve pack.
7. Internal insulation of field piping may be required.
8. Field piping casing penetrations must be cut in the field to match individual job requirements.
9. All dimensions also apply to units with Electric Heat Only.

DIMENSIONAL DATA

MODEL THBE BOTTOM RETURN (CONT'D)

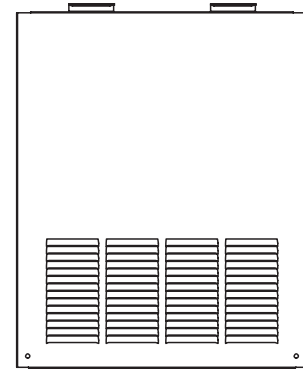
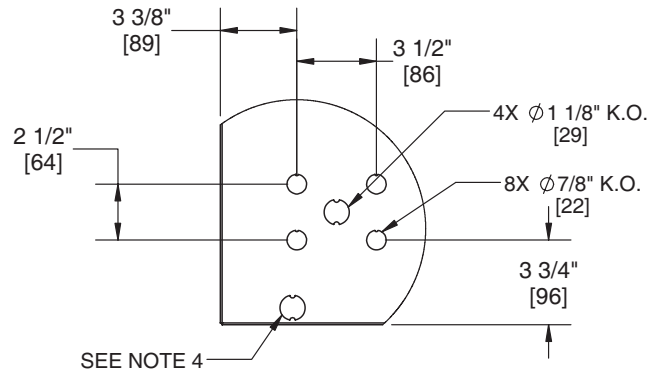
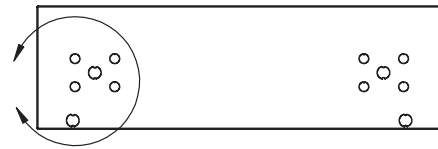
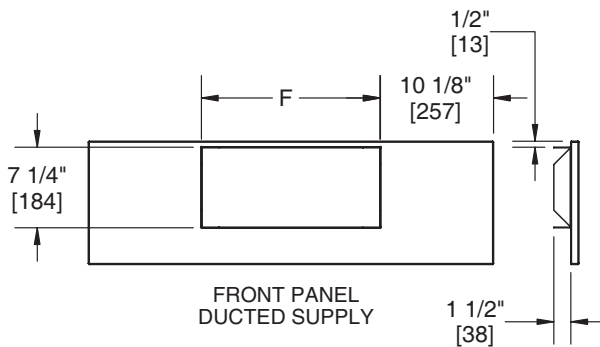
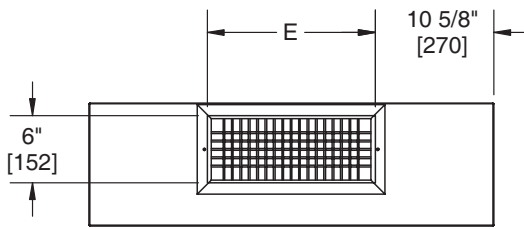
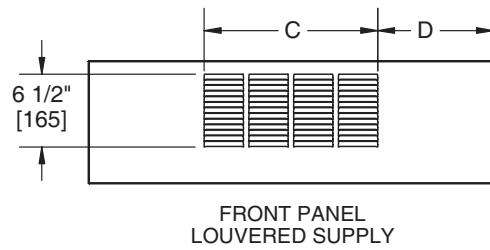

DIMENSIONS				
UNIT SIZE	C	D	E	F
02	15 1/2" [394]	10 3/8" [264]	15" [381]	16" [406]
03	15 1/2" [394]	12" [305]	18" [457]	19 1/4" [489]
04	23 1/2" [597]	10 1/2" [267]	23" [584]	24 1/4" [616]
06	27 1/2" [699]	11 7/8" [302]	30" [762]	31" [787]
08	35 1/2" [902]	11 3/8" [289]	37" [940]	38" [965]
09	39 1/2" [1003]	11 1/2" [292]	41" [1041]	42 1/4" [1073]
10	51 1/2" [1308]	10 3/8" [264]	23" [584]	52" [1321]
12	59 1/2" [1511]	10 3/8" [264]	27" [686]	60" [1524]

NOTES:

1. All dimensions are inches [millimeters]. All dimensions ± 1/4" [6mm]. Metric values are soft conversions.
2. Left hand unit shown, right hand unit opposite.
3. Provide sufficient clearance to access electrical controls and comply with applicable codes and ordinances.
4. Drain piping should be routed through casing opening indicated to provide proper slope.
5. Bottom panel removable for access to filter and fan assembly.
6. Corner panels are removable to access electrical enclosure, coil and valve pack.
7. Internal insulation of field piping may be required.
8. Field piping casing penetrations must be cut in the field to match individual job requirements.
9. All dimensions also apply to units with Electric Heat Only.

DIMENSIONAL DATA

MODEL THBE BOTTOM RETURN (CONT'D)

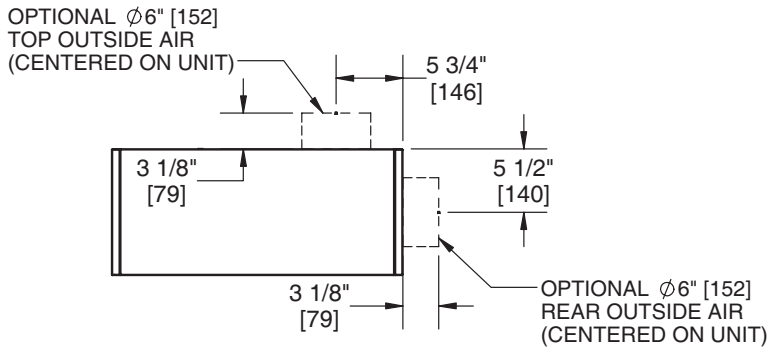

OPTIONAL OUTSIDE AIR
FLANGE ONLY
DETAIL

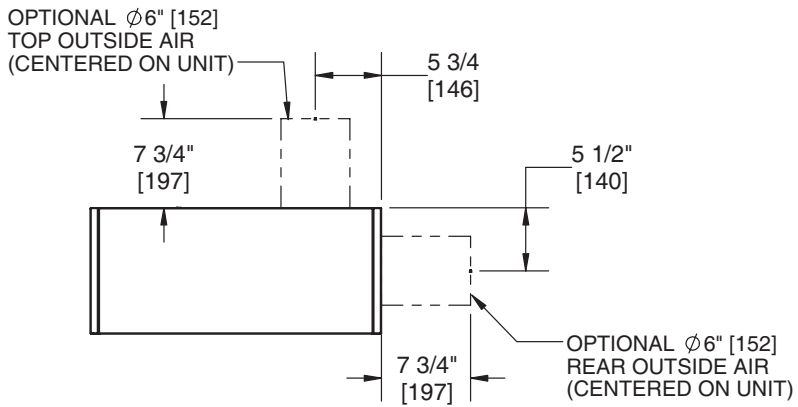

OPTIONAL OUTSIDE AIR
WITH MANUAL DAMPER
DETAIL

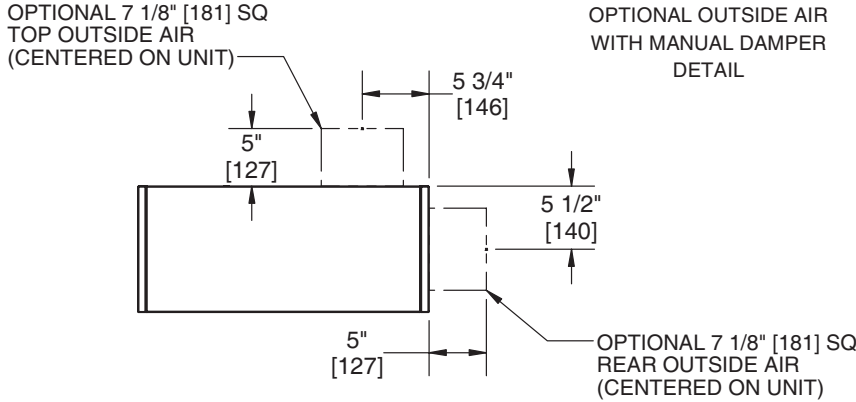

OPTIONAL OUTSIDE AIR
WITH MOTORIZED DAMPER
DETAIL

1. All dimensions are inches [millimeters]. All dimensions $\pm 1/4''$ [6mm]. Metric values are soft conversions.
2. Left hand unit shown, right hand unit opposite.
3. Provide sufficient clearance to access electrical controls and comply with applicable codes and ordinances.
4. Drain piping should be routed through casing opening indicated to provide proper slope.
5. Bottom panel removable for access to filter and fan assembly.
6. Corner panels are removable to access electrical enclosure, coil and valve pack.
7. Internal insulation of field piping may be required.
8. Field piping casing penetrations must be cut in the field to match individual job requirements.
9. All dimensions also apply to units with Electric Heat Only.

GUIDE SPECIFICATIONS

GENERAL

Furnish and install Titus Model RBH Horizontal Direct Drive Fan Coil Units where indicated on the plans and in the specifications. Units shall be completely factory assembled, tested and shipped as one piece. Units shall be capable of meeting or exceeding the scheduled capacities for cooling, heating and air delivery. Unit dimensions for each model and size shall be considered maximums. Units shall be cETLus listed in compliance with UL/ANSI Standard 1995, and be certified as complying with the latest edition of AHRI Standard 440.

CONSTRUCTION

Unit chassis shall be fabricated of galvanized steel panels. Exterior panels shall be insulated with 3/8" thick elastomeric closed cell foam insulation. Insulation shall conform to UL 181 for erosion and NFPA 90A for fire and smoke, and comply with a 25/50 Flame Spread and Smoke Developed Index per ASTM E-84 or UL 723. Additionally, insulation shall comply with Antimicrobial Performance Rating of 0, no observed growth, per ASTM G-21. Polyethylene insulation is not acceptable.

Ducted units shall have a minimum 1-1/2" duct collar on the discharge. Plenum and exposed units shall have a minimum 3/4" duct collar on the return.

Exposed units shall have exterior panels fabricated of galvanized steel. The fan and filter bottom access panel shall be attached with quarter turn quick open fasteners to allow for easy removal and access for service.

Unit mounting shall be by hanger brackets provided at four locations.

PAINTED FINISH

Painted cabinet exterior panels shall be finished with a heat cured anodic acrylic powder paint of the standard factory color.

SOUND

Ducted units shall have published sound power level data tested in accordance with AHRI Standard 260-2012. Exposed units shall have published sound power level data tested in accordance with AHRI Standard 350-2015 (non-ducted equipment).

FAN ASSEMBLY

Unit fan shall be a dynamically balanced, forwardly curved, DWDI centrifugal type constructed of 18 gauge zinc coated galvanized steel for corrosion resistance. Motors shall be high efficiency, permanently lubricated sleeve bearing, permanent split-capacitor type with UL and CSA listed automatic reset thermal overload protection and three separate horsepower taps. Single speed motors are not acceptable.

The fan assembly shall be easily removable for servicing the motor and blower at, or away from the unit. The entire fan assembly shall be able to come out of the unit by removing two screws and unplugging the motor. Plenum unit fan assemblies shall be easily serviced through an access panel in casing.

Devices used to energize and de-energize (switch) fan speeds must be silent. Magnetic, mercury, and/or quiet relays and/or contactors are not acceptable.

Option: Provide Electronically Commutated (EC) Motor capable of operation with low voltage 3 speed thermostat. Motor shall come factory programmed and configured for 3 speed operation.

Option: Motor shall be capable of accepting a 2-10 VDC output from BAS.

Option: Provide an electronic (SCR) fan speed controller as an aid in balancing the fan capacity. The speed controller shall have a turn down stop to prevent the possibility of harming the motor bearings, and incorporate electrical noise suppression to minimize noise on the incoming power lines.

GUIDE SPECIFICATIONS

COILS

Cooling and heating coils shall optimize rows and fins per inch to meet the specified capacity. Coils shall have seamless copper tubes and shall be mechanically expanded to provide an efficient, permanent bond between the tube and fin. Fins shall have high efficiency aluminum surface optimized for heat transfer, air pressure drop and moisture carryover.

Each coil shall be pressured to 450 PSIG and rated for a maximum of 450 PSIG working pressure.

Steam coils shall be standard steam type suitable for air temperatures above 35°F and 15 PSIG maximum working pressure.

Option: Coil casing shall be fabricated from Stainless Steel.

Coils shall be provided with a manual air vent fitting to allow for coil venting.

Option: Provide automatic air vents in lieu of manual air vents.

Heating coils shall be furnished in the reheat or preheat position on units with chilled water coils, or in the reheat position for DX coils.

DRAIN PANS

Primary condensate drain pans shall be single wall, galvanized steel for corrosion resistance, and extend under the entire cooling coil. Drain pans shall be of one-piece construction and be double sloped for condensate removal.

Drain pans shall be fully removable without the use of any tools.

The drain pan shall be externally insulated with a fire retardant, closed cell foam insulation. The insulation shall carry no more than a 25/50 Flame Spread and Smoke Developed Rating per ASTM E-84 and UL 723 and an Antimicrobial Performance Rating of 0, no observed growth, per ASTM G-21.

Option: Provide a single wall primary drain pan constructed entirely of stainless steel for superior corrosion resistance. Stainless steel drain pans shall be externally insulated.

Option: Provide a secondary drain connection on the primary drain pan for condensate overflow.

FILTERS

Plenum and exposed units shall be furnished with a minimum 1" nominal glass fiber throwaway filter. Filters shall be tight fitting to prevent air bypass. Plenum unit filters shall be easily removable from the bottom of the unit without the need for tools.

Option: Provide unit with 1" pleated filter (MERV 8).

Option: Provide unit with 1" pleated filter (MERV 13).

ELECTRICAL

Units shall be furnished with single point power connection. Provide an electrical junction box for motor and other electrical terminations.

GUIDE SPECIFICATIONS

ELECTRIC HEAT

Furnish an electric resistance heating assembly as an integral part of the fan coil unit, with the heating capacity, voltage and kilowatts scheduled. The heater assembly shall be designed and rated for installation on the fan coil unit without the use of duct extensions or transitions, and be located in the unit as to not expose the fan assembly to excessive leaving air temperatures that could affect motor performance.

The heater and unit assembly shall be listed for zero clearance and meet all NEC requirements, and be cETLus listed with the unit as an assembly in compliance with UL/ANSI Standard 1995.

Heating elements shall be open coil type nichrome wire mounted in ceramic insulators and located in an insulated galvanized steel housing. Elements shall terminate in a machine staked stainless steel terminal secured with stainless steel hardware for corrosion resistance. The element support brackets shall be spaced no greater than 3-1/2" on center. Internal wiring shall be rated for 105°C minimum. Heaters shall include overtemperature protection consisting of an automatic reset primary thermal limit and back up secondary thermal limit. Heaters shall be single stage.

Option: Provide a manual reset secondary thermal limit.

Units with electric heat shall have an incoming line power distribution block shall be designated to accept single point power wiring capable of carrying 125% of the calculated load current.

Option: Devices used to energize and de-energize (switch) electric heat must be silent. Magnetic, mercury, and/or quiet relays and/or contactors are not acceptable.

PIPING PACKAGES

Provide a standard factory assembled valve piping package to consist of a 2 or 3 way, on/off, motorized electric control valve and two ball isolation valves. Control valves are piped normally closed to cold water coils and normally open to hot water coils. Maximum entering water temperature on the control valve is 200 °F.

Provide high pressure close-off actuators for 2-way or 3-way on/off control valves. Maximum close-off pressure is 125 PSIG.

Option: Valve package mounted from the factory with structural supports. Field mounted valves are not acceptable.

Option: Provide 3-wire floating point modulating control valve (fail-in-place) in lieu of standard 2-position control valve with factory assembled valve piping package.

Option: Provide 0-10V proportional control valve (fail-in-place) in lieu of standard 2-position control valve with factory assembled valve piping package.

Option: Provide a fixed flow control device with a removable cartridge or each piping package.

Option: Normally open in lieu of Normally Closed on/off valves.

Option: Spring return (N.O. or N.C.) modulating control valve.

Option: Spring return (N.O. or N.C.) proportional control valve.

Option: Provide pressure-temperature ports for each piping package.

Piping package shall be completely factory assembled, including interconnecting pipe, and shipped separate from the unit for field installation on the coil, so as to minimize the risk of freight damage.

