

**Louvered Return Filter Grilles • AeroBlade Series • Steel**

**Models:** 25RFL • 30° Deflection • Long Blades • 1/2" Spacing  
 25RFS • 30° Deflection • Short Blades • 1/2" Spacing

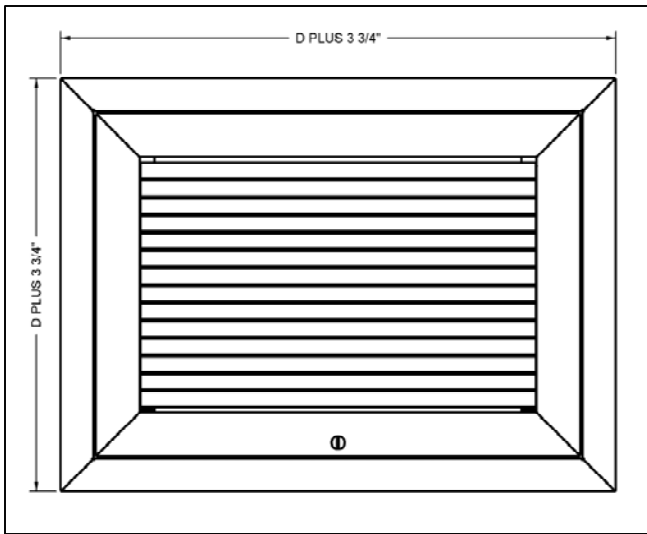

Face View:  
 Border Type 1 (Surface Mount) & Border Type 3 (Lay-in T-Bar)

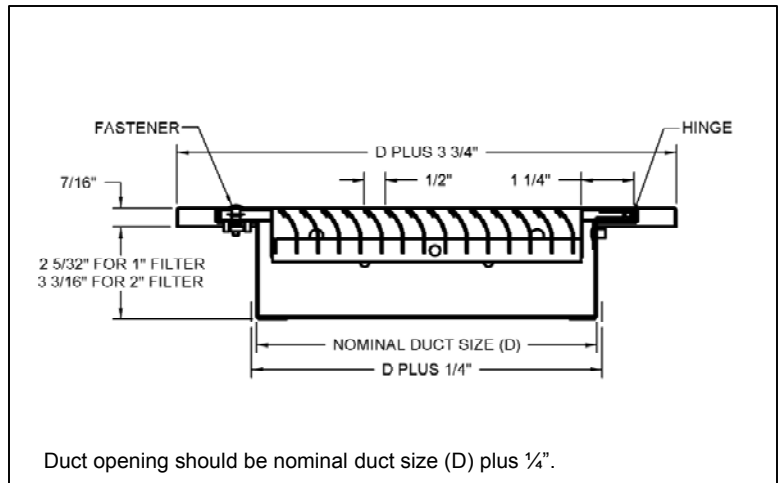

Side Cross-Sectional View:  
 Border Type 1 (Surface Mount) & Border Type 3 (Lay-in T-Bar)

**Hinge Location Options:**

- Hinged Top
- Hinged Left
- Hinged Right
- Hinged Bottom
- No Hinge

**Finish Options:**

- Standard Finish: #26 White
- Other Finish: \_\_\_\_\_

**Fastening Options:**

- Quarter-Turn Fastener (standard)
- Knurled Knob (optional)

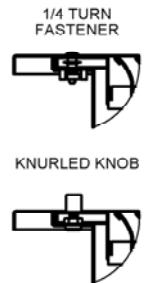

**Available Sizes:** 10" x 8" to 48" x 36" in one-inch increments. Fractional and oversize filter grilles are not available.  
 Maximum size for border type 3 is module size minus 4".

All dimensions are in inches.

**General Description**

- Series 25 filter grilles feature louvers spaced 1/2" apart.
- 25 series models are available in common filter sizes. 1" thick filters may be purchased from hardware stores for the most common sizes.
- Blade deflection angle is 30°.
- Quarter turn fasteners are standard to make filter access easy.
- Knurled knob fastener available as option
- All dimensions are ± 1/16".
- Filters by others
- Dimensions are the same for border type 1 (surface mount) and border type 3 (lay-in T-bar)