

DTFS-F Phantom IQ™

Ultra Quiet Fan Powered Terminal, Series Flow
Direct Digital Control, Pressure Independent

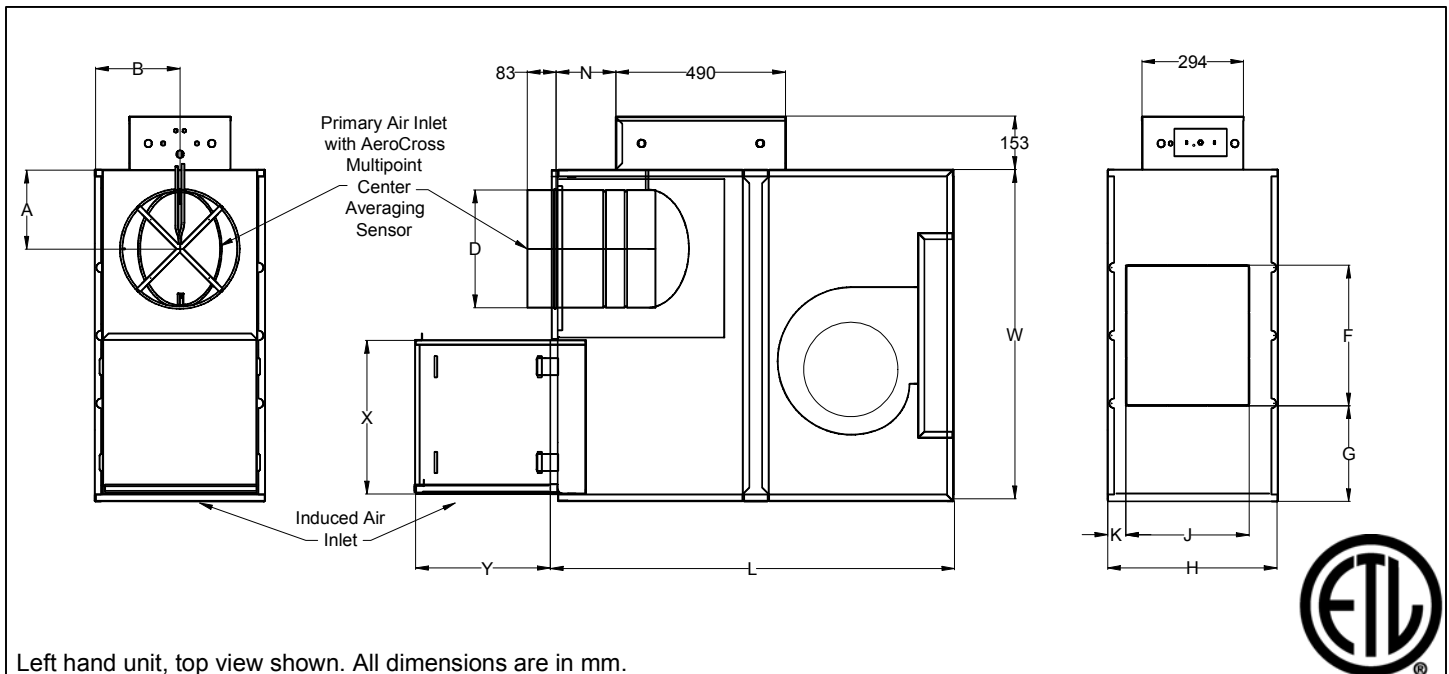

Left hand unit, top view shown. All dimensions are in mm.

Unit Size	Inlet Size	A	B	X	Y	D	Induced Air Inlet		F	G	H	J	K	L	N	W	Filter Size
							Height	Width									
B	6	147	196	483	352	144	321	217	356	282	392	279	55	1092	70	907	270 x 343
	8	147				70											
	10	172				119											
	12	196				119											
C	6	147	196	483	352	144	321	217	356	282	392	279	55	1092	70	907	270 x 343
	8	147				70											
	10	172				119											
	12	196				119											
D	10	172	254	444	291	242	422	364	404	286	490	358	49	1145	119	956	441 x 417
	12	196				119											
	14	245				168											
	16	270				168											
E	12	196	254	444	291	291	422	364	404	286	490	358	49	1145	119	956	441 x 417
	14	245				168											
	16	270				168											

Motor Amperage Ratings

Unit Size	Motor hp	120/1/60 FLA	208/240/1/60 FLA	277/1/60 FLA
B	1/6	2.3	0.9	0.8
C	1/4	4.0	1.8	1.4
D	1/3	8.5	3.6	3.0
E	3/4	8.6	4.2	4.5

FLA = Full Load Amperage, as tested in accordance with UL 1995

All fan motors are single phase, same voltage as electric coil (when supplied), with exception that 277V motors are used with 480V, 3 phase coils (4 wire wye).

Accessories (Optional)

Check if provided.

- Induced Air Filter, 25mm thick, disposable construction type.
- Fan disconnect switch (not available on units with optional electric coils.)
- Fibre Free Liner
- SteriLoc Liner
- Fan unit fusing
- Cam Latch for Access Door
- UltraLoc Liner
- 25mm Fiberglass Liner
- Hanger Brackets

Accessories (Optional)

Hot Water Coil Section

- 13mm copper tubes
- Aluminum ripple fins, 10 per inch
- Connections: Male solder, 13mm for both 1-row and 2-row. Left hand or right hand connections.
- Galvanized steel casing
- Flanged duct connection.
- Coil is installed on discharge of unit.

- 1 Row
- 2 Row

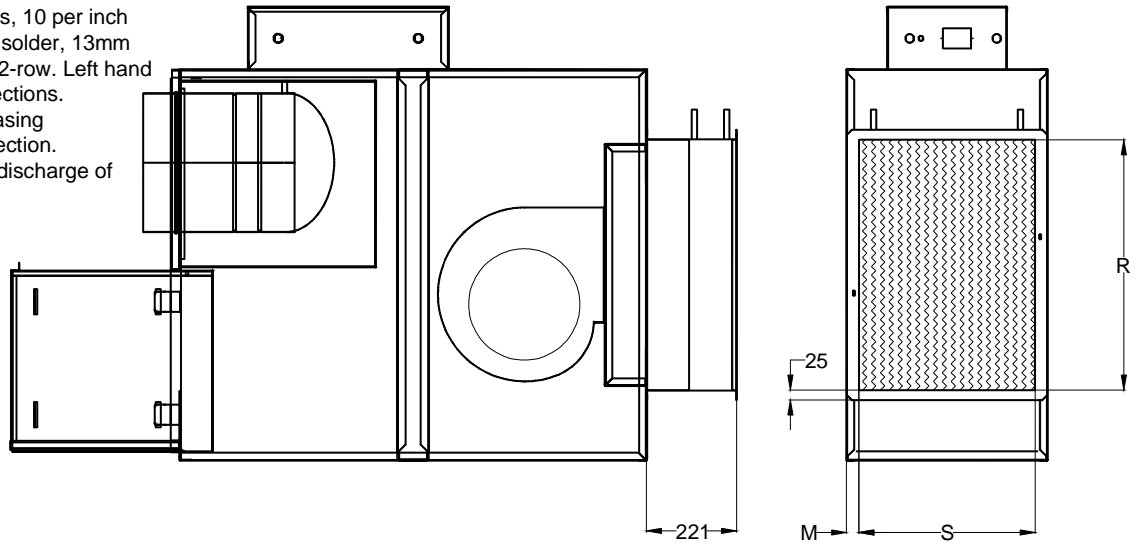

Unit Size	M (1 row)	M (2 row)	R	S
B,C	25	25	502	306
D,E	25	31	613	429

R and S are inside dimensions.

Electric Coil Section

Standard Features

- Single side access to low voltage, high voltage, and electric heater controls.
- Automatic reset thermal cutouts, one per element
- Single point electrical connection for entire unit
- Positive pressure flow switch
- Flanged duct connection
- Coil is installed at discharge of unit.
- Transformer

Options

- Fuse Block
- Disconnect switch, door interlock type
- Manual reset cutout
- Dust tight construction
- Mercury contactors

Supply Voltage

- 208V, 1 ph, 60Hz
- 240V, 1 ph, 60Hz
- 277V, 1 ph, 60Hz
- 208V, 3 ph, 60Hz
- 480V, 3 ph, 60Hz (4 wire wye only)

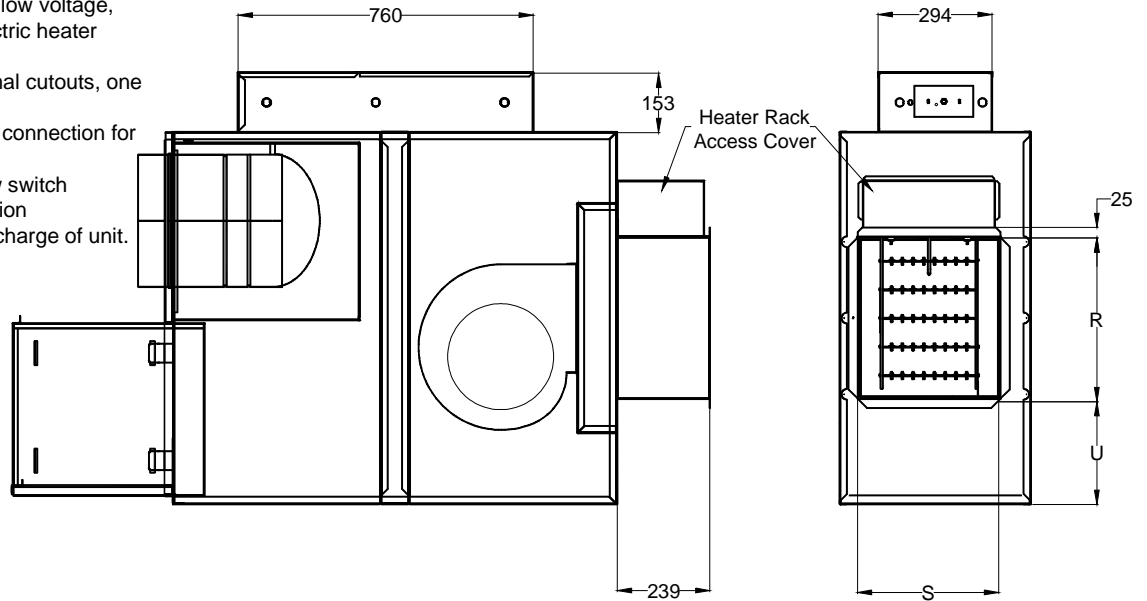

Unit Size	U	R	S	T
B,C	279	355	282	53
D,E	270	417	368	77

R and S are inside dimensions.

Accessories (Optional)

Hanger Bracket Location

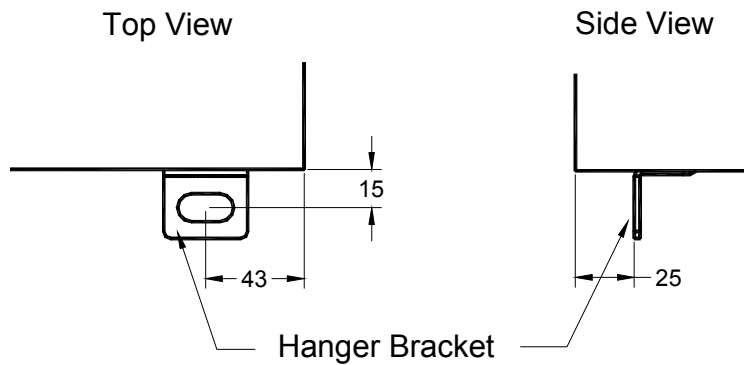

General Description

- Heavy steel casing, with leak resistant construction.
- Dual density insulation, coated to prevent air erosion, meet requirements of NFPA 90A and UL 181.
- Energy efficient fan motor, permanent split capacitor type, mounted in vibration isolators.
- Adjustable SCR fan speed control with minimum voltage stop.
- Patent-pending FAST™ attenuator system that greatly reduces radiated sound power levels. The FAST™ attenuator ships assembled inside the casing, pulls out easily and snaps into place for operation.
- Top and bottom access panels can be removed for service.
- Multipoint, center averaging velocity sensor.
- Primary air flow balancing connections.
- Pressure independent primary flow control.
- Single point electrical connections.
- Rectangular discharge opening is designed for flanged duct connections.

This submittal is meant to demonstrate general dimensions of this product. The drawings are not meant to detail every aspect of the product. Drawings are not to scale. Titus reserves the right to make changes without written notice.



605 Shiloh Road • Plano, Texas 75074 • 972-212-4800