

TurboFuser Heavy Duty High Capacity Diffuser Single or Multiple Nozzles • Adjustable

Model: TBF • Steel Nozzle • Steel Panel • Aluminum Border

TBF-AA • Aluminum Nozzle • Aluminum Panel • Aluminum Border

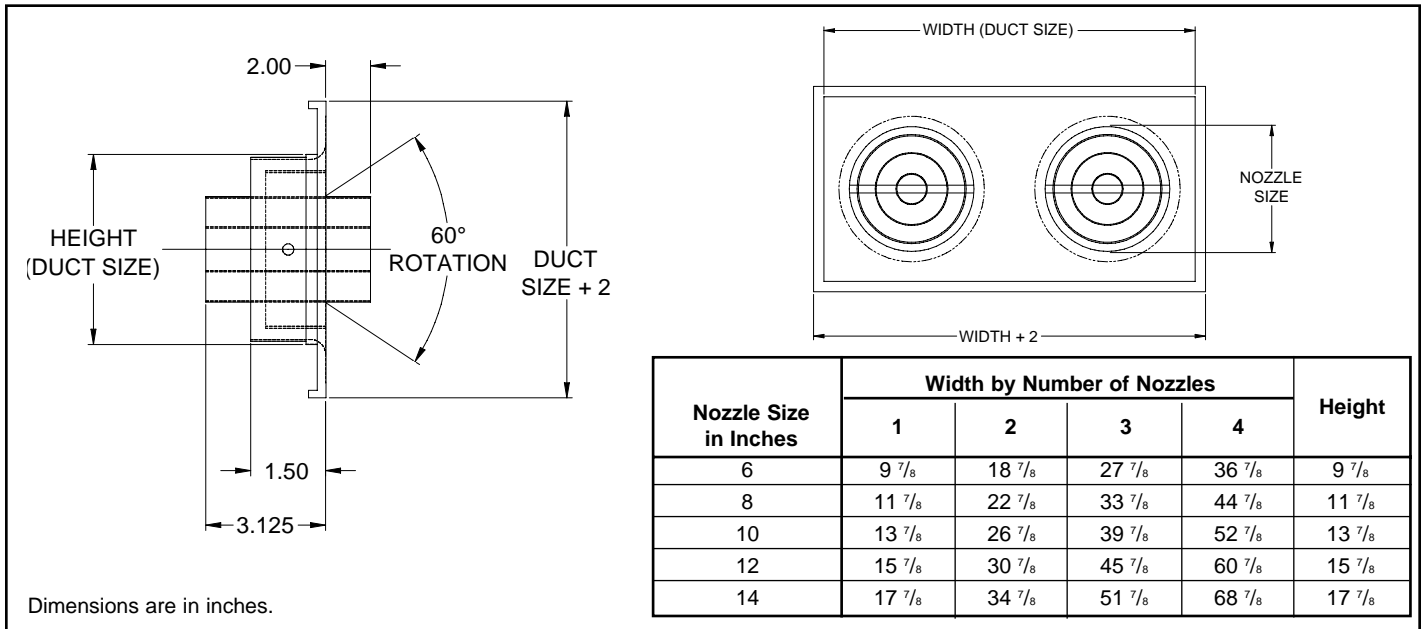

Typical Installation

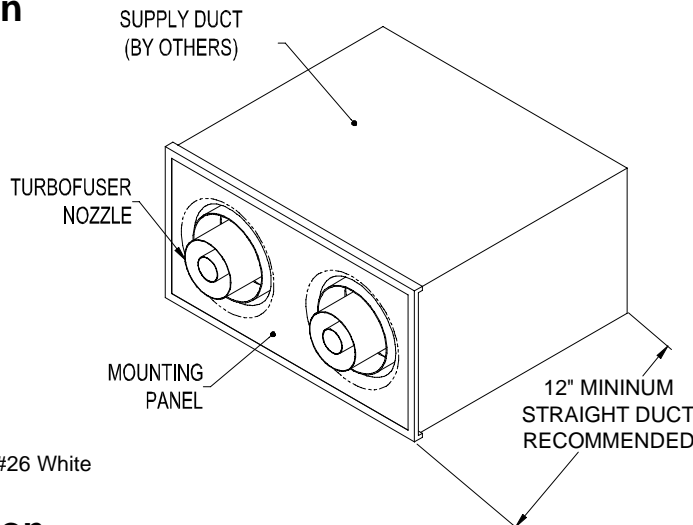

Standard Finish: #26 White

General Description

- TurboFuser - Models TBF and TBF-AA are designed for heating and cooling of large spaces; as well as spot heating and cooling in office spaces.
- Nozzles can be individually adjusted vertically or horizontally to 30 degrees perpendicular to the mounting panel.
- High free area design provides air distribution with lower noise and less pressure loss.
- Heavy duty construction - panel mounted nozzles are available with one thru four nozzles. Nozzles range in size from 6 to 14 inches wide.
- Panel should be supported independent of mounting hardware when installed in T-Bar ceiling.
- Pivot bars are individually adjustable to maintain position at numerous deflection settings.
- Model TBF is steel with aluminum border. Model TBF-AA is aluminum with miscellaneous steel components.