

**ML-TZ** • 3/4" Slot – Supply

**MLR-TZ** • 3/4" Slot – Return

Border types: LT, DF, NT

TechZone™ Series Linear Slot Diffusers  
Aluminum • Modulinear  
For Armstrong TechZone™ Ceiling System

ML-TZ Supply

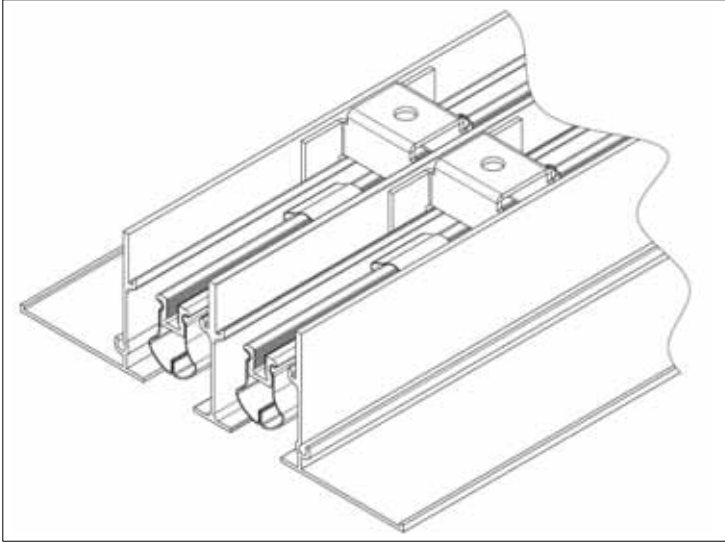

MLR-TZ Return

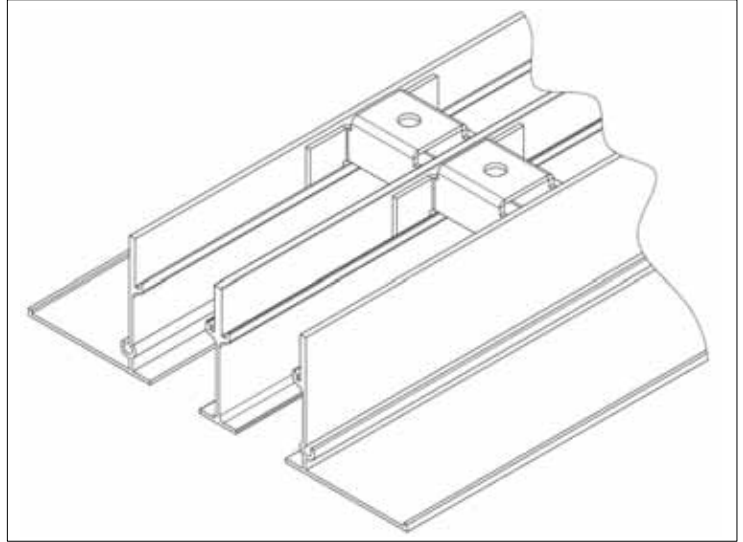

Border Type LT

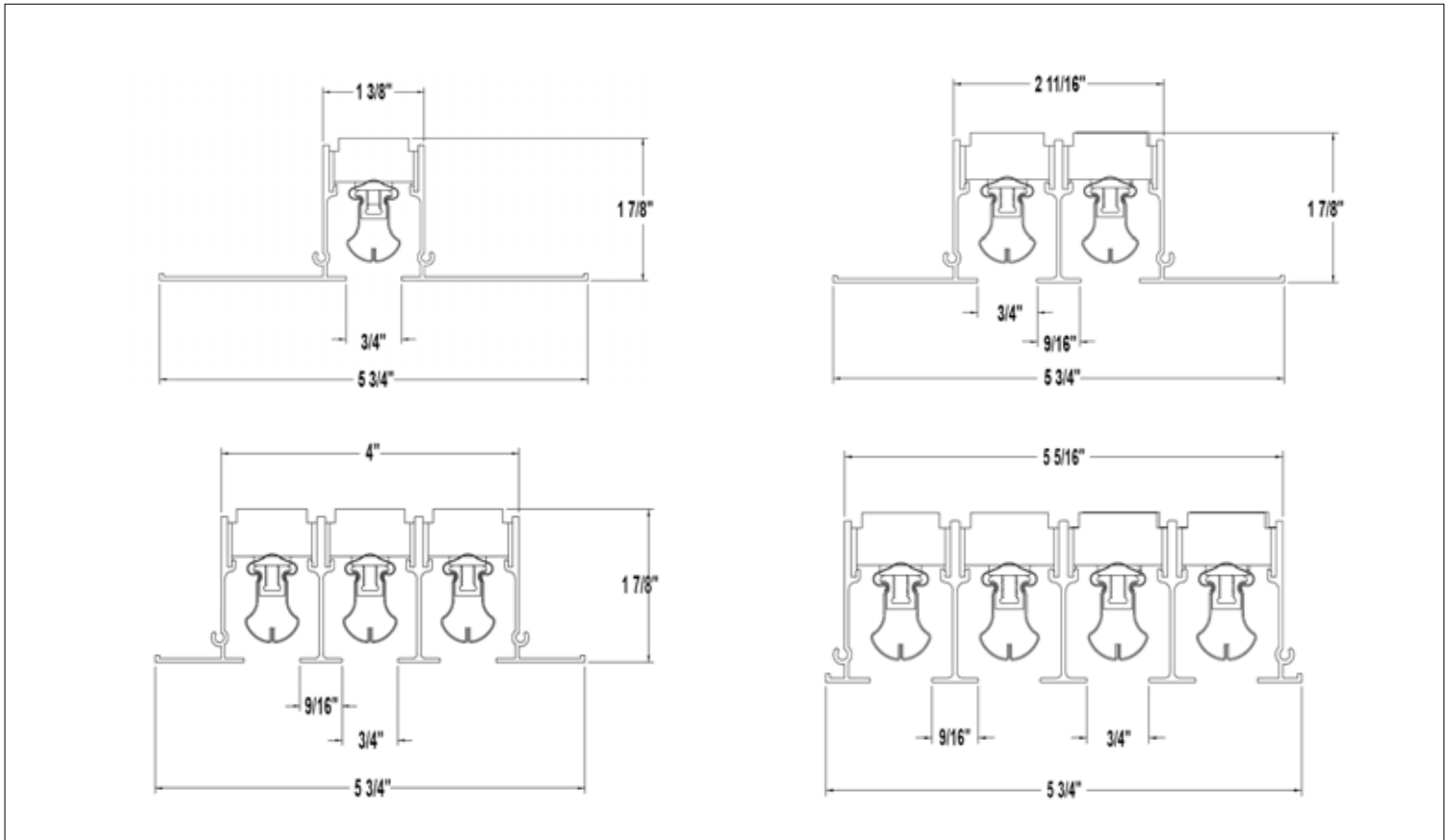

Border Type DF (15/16" Tegular – Drop Face)

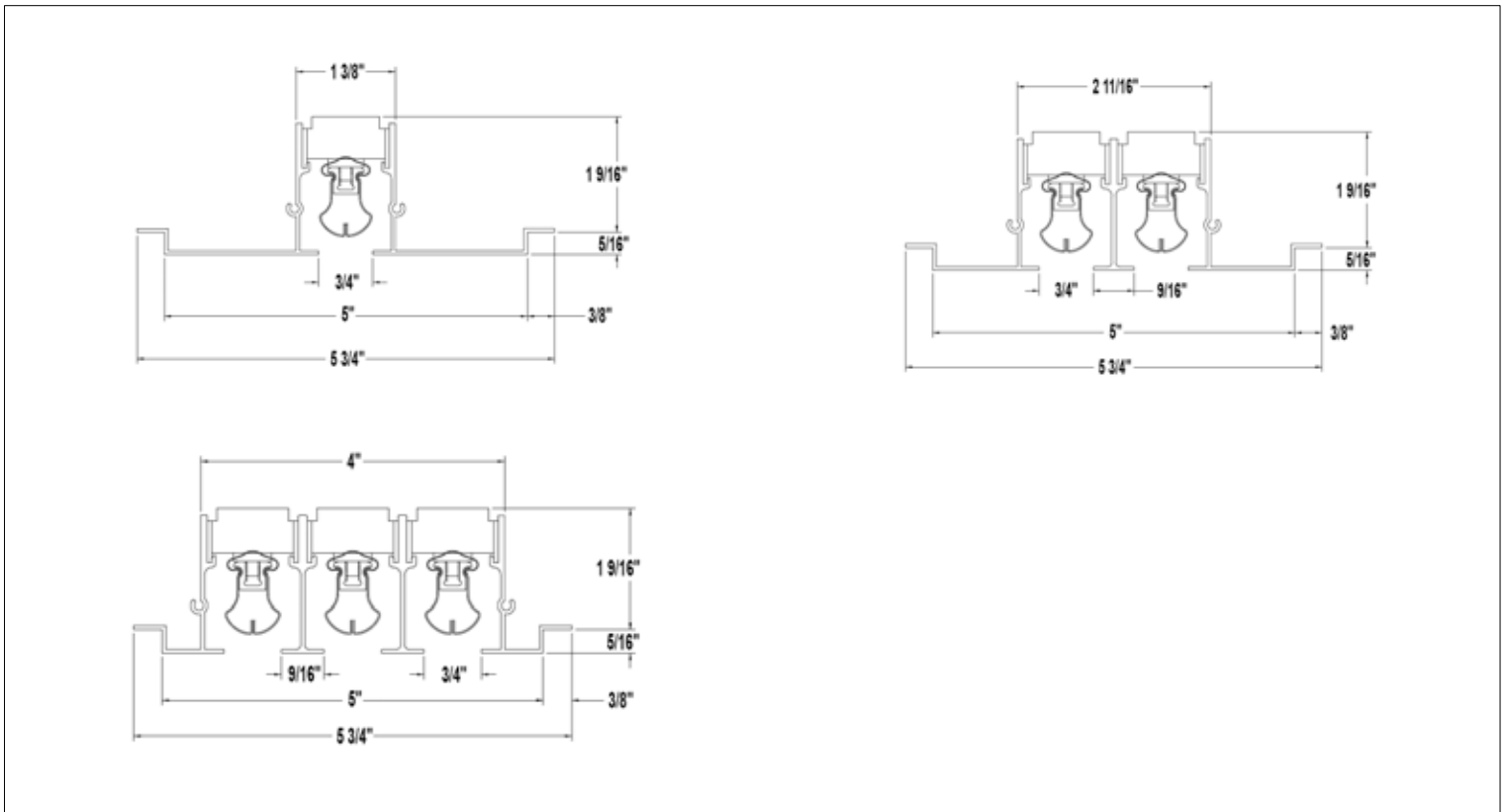

Border Type NT (9/16" Narrow Tee)

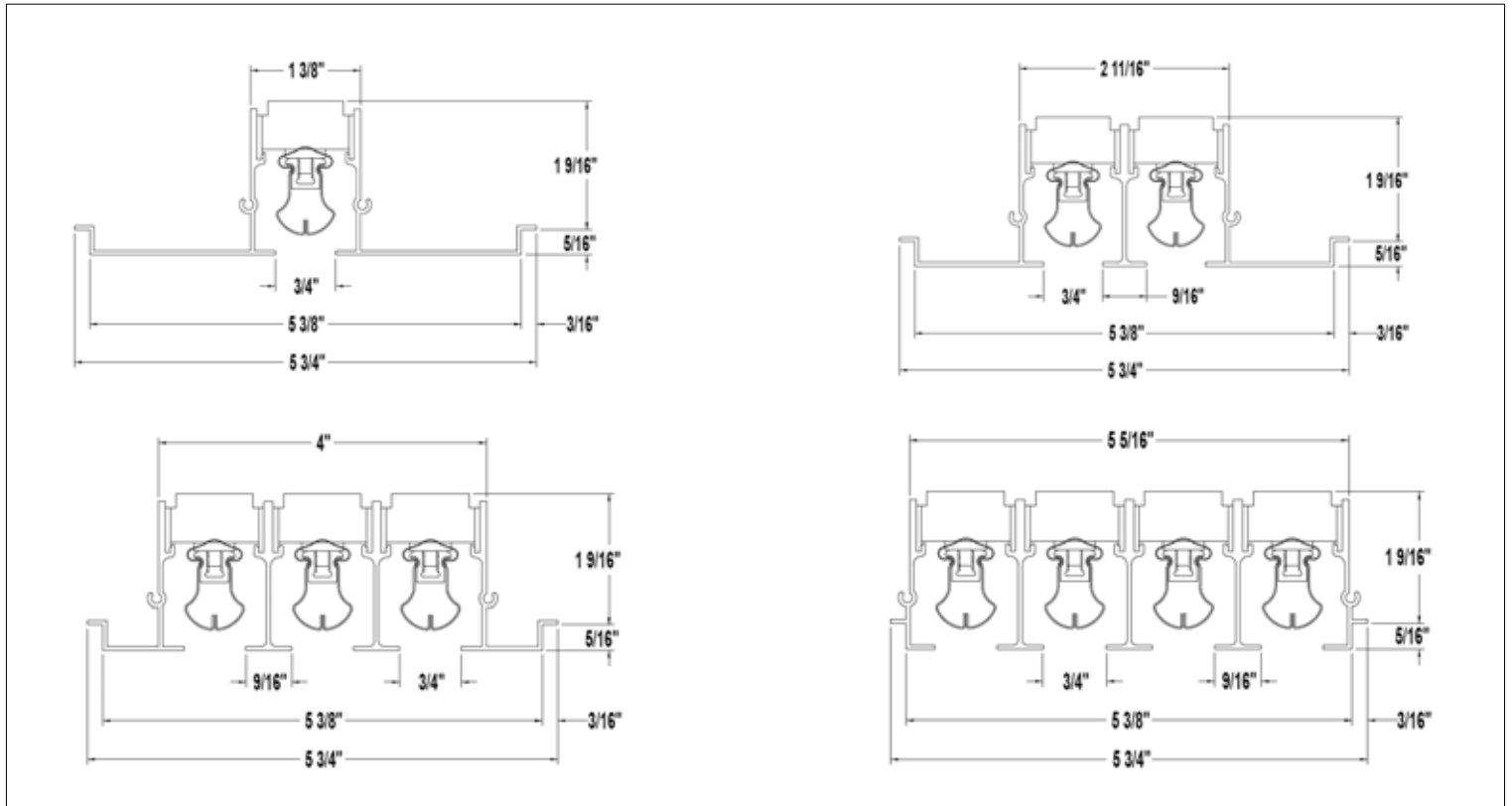

End Fabrication

LT Border

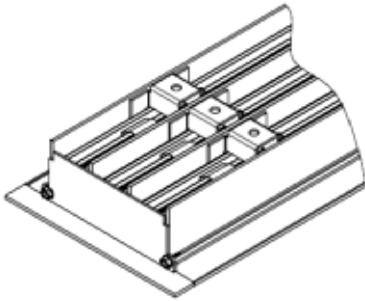
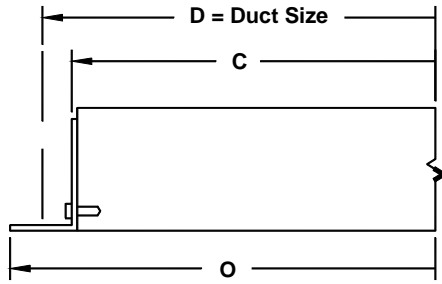

DF, NT Borders

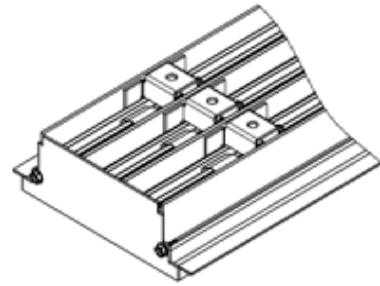
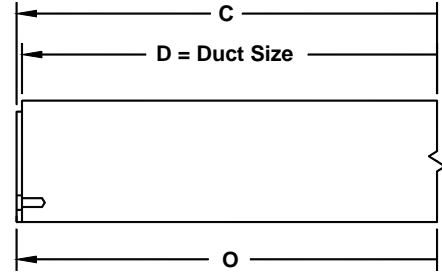

Overall Length for LT, DF and NT Borders

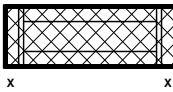
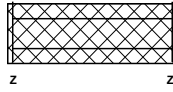
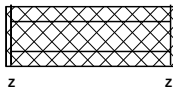
Nominal Length (inches)	 Border LT		 DF Border		 NT Border	
	C	O	C	O	C	O
24	22 5/8	23 13/16	23	23	23 3/8	23 3/8
30	28 5/8	29 13/16	29	29	29 3/8	29 3/8
36	34 5/8	35 13/16	35	35	35 3/8	35 3/8
48	46 5/8	47 13/16	47	47	47 3/8	47 3/8
60	58 5/8	59 13/16	59	59	59 3/8	59 3/8
72	70 5/8	71 13/16	71	71	71 3/8	71 3/8

Standard Finish: #31 Armstrong Global White

General Description

- Models ML-TZ, MLR-TZ are designed to fit into Armstrong TechZone ceiling grid systems.
- ML-TZ is a supply diffuser with modulinear pattern controllers. The unique design of the pattern controller assembly allows changes in the direction and volume of the air flow from the diffuser face.
- MLR-TZ is a matching return diffuser.
- Standard diffuser lengths are 24", 30", 36", 48", 60", and 72".
- Diffusers are available in three border types: LT (Lay-in Tee), DF (Drop Face), and NT (Narrow Tee).
- Material is extruded aluminum with steel pattern controllers.

This submittal is meant to demonstrate general dimensions of this product. The drawings are not meant to detail every aspect of the product. Drawings are not to scale.

Titus reserves the right to make changes without written notice.