

DIMENSIONS

Redefine your comfort zone.™ | www.titus-hvac.com

MLT UNIT DIMENSIONS

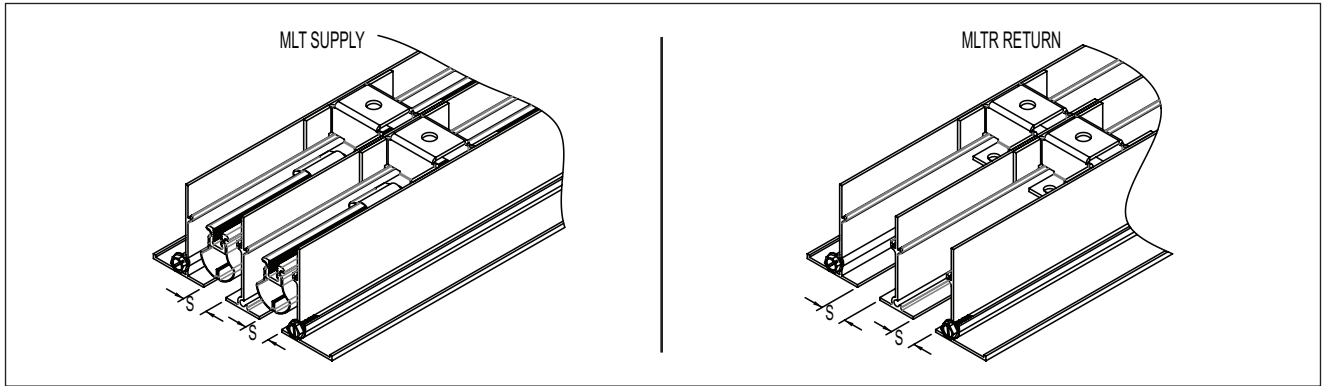

BORDER 1B

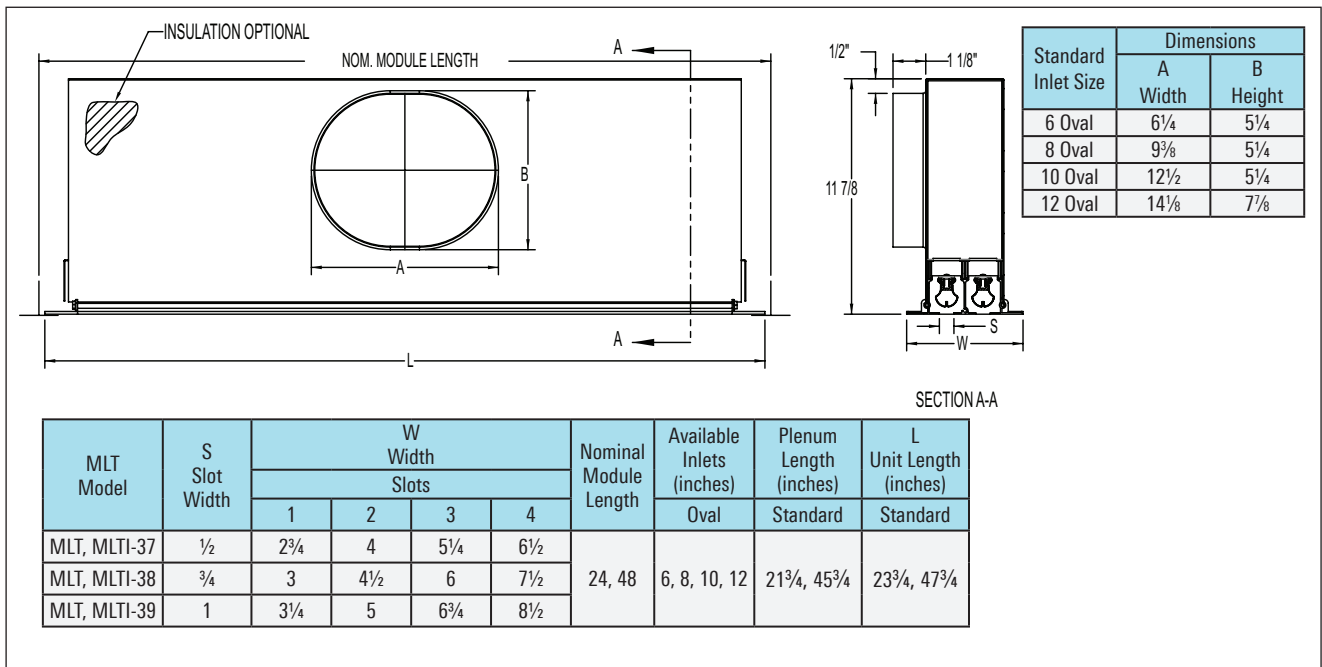

INSULATION OPTIONAL

NOM. MODULE LENGTH

A

B

L

SECTION A-A

Standard Inlet Size	Dimensions	
	A Width	B Height
6 Oval	6¼	5¼
8 Oval	9⅝	5¼
10 Oval	12½	5¼
12 Oval	14⅞	7⅞

MLT Model	S Slot Width	W Width Slots				Nominal Module Length	Available Inlets (inches)	Plenum Length (inches)	L Unit Length (inches)
		1	2	3	4				
MLT, MLTI-37	½	2¾	4	5¼	6½	24, 48	6, 8, 10, 12	21¾, 45¾	23¾, 47¾
MLT, MLTI-38	¾	3	4½	6	7½				
MLT, MLTI-39	1	3¾	5	6¾	8½				

BORDER NT

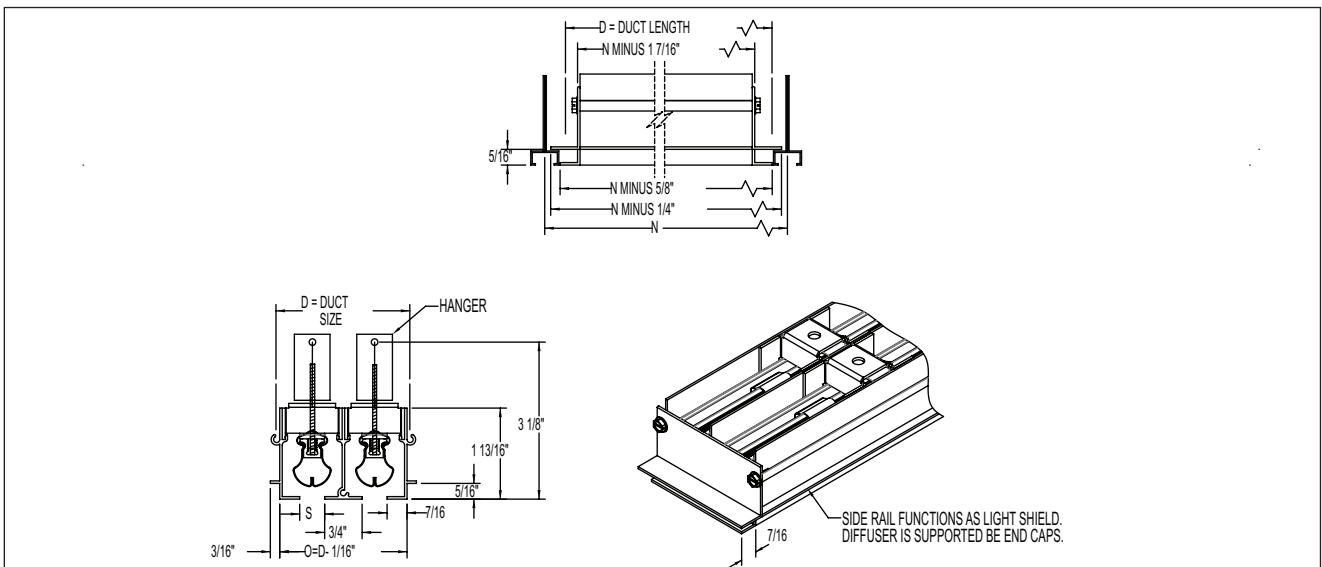

D = DUCT LENGTH

N MINUS 1 7/16"

5/16"

N MINUS 5/8"

N MINUS 1/4"

N

D = DUCT SIZE

HANGER

3 1/8"

1 13/16"

5/16"

S

3/4"

7/16"

3/16"

O = D - 1/16"

7/16"

SIDE RAIL FUNCTIONS AS LIGHT SHIELD. DIFFUSER IS SUPPORTED BY END CAPS.