

TBL UNIT DIMENSIONS / DISCHARGE ARRANGEMENT 2

Notes:

1. All dimensions are inches [millimeters] +/- 1/4" [6mm]. Metric values are soft conversions.
2. Motor/drive location may be specified Left or Right Hand. Standard control enclosure location matches motor/drive position.
3. Provide sufficient clearance to access electrical control and comply with all applicable codes and ordinances
4. Maximum total internal coil rows: 6
5. All drawings subject to change without prior notice
6. Left hand unit shown; right hand unit has CW and HW piping connections mirrored
7. Filter assembly runs the full length of the unit size
8. Drawings not for installation purposes

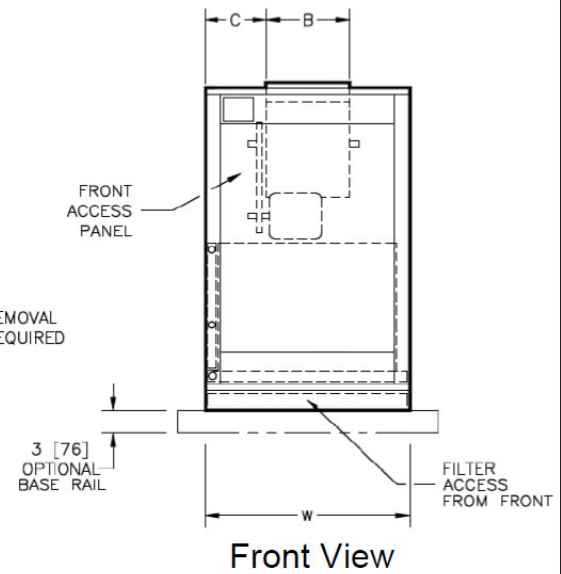
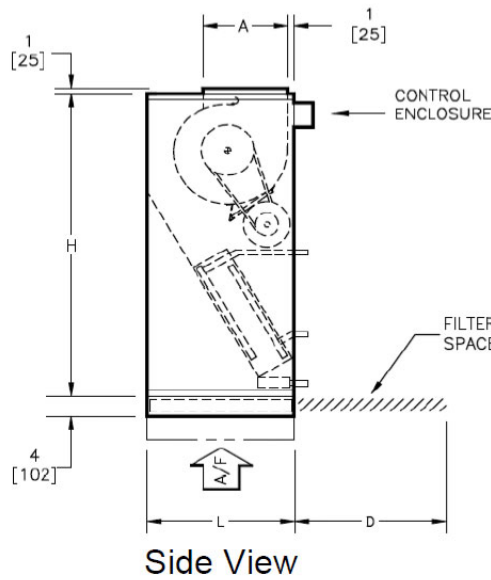
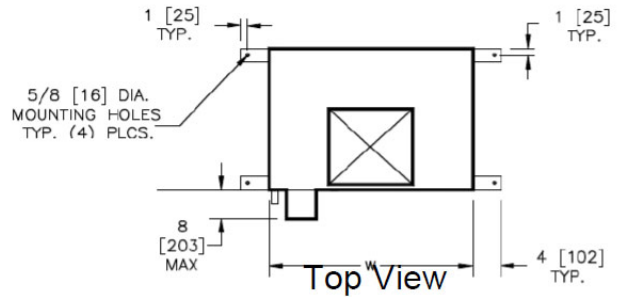

| Dimensions |                                 |        |           |          |          |              |              |               |          |
|------------|---------------------------------|--------|-----------|----------|----------|--------------|--------------|---------------|----------|
| Unit Size  | Filter Size                     | Qty    | H         | W        | L        | A            | B            | C             | D        |
| 08         | 16 x 20 x 2<br>[406 x 508 x 51] | 1      | 46 [1168] | 26 [660] | 19 [483] | 6 1/2 [165]  | 6 7/8 [175]  | 9 9/16 [243]  | 16 [406] |
| 12         | 20 x 20 x 2<br>[508 x 508 x 51] | 1      | 46 [1168] | 26 [660] | 21 [533] | 7 1/2 [190]  | 8 1/4 [210]  | 8 7/8 [225]   | 20 [508] |
| 16         | 24 x 24 x 2<br>[610 x 610 x 51] | 1      | 54 [1372] | 29 [737] | 25 [635] | 7 1/2 [190]  | 10 1/4 [260] | 9 3/8 [238]   | 24 [610] |
| 20         | 24 x 24 x 2<br>[610 x 610 x 51] | 1      | 54 [1372] | 29 [737] | 28 [711] | 11 3/8 [289] | 13 1/4 [337] | 7 7/8 [200]   | 24 [610] |
| 25         | 24 x 24 x 2<br>[610 x 610 x 51] | 1 Each | 60 [1524] | 39 [991] | 28 [711] | 13 1/2 [343] | 12 7/8 [327] | 13 1/16 [332] | 24 [610] |
| 30         | 12 x 24 x 2<br>[305 x 610 x 51] | 1 Each | 60 [1524] | 39 [991] | 28 [711] | 15 1/4 [387] | 15 [381]     | 12 [305]      | 24 [610] |

TBL UNIT DIMENSIONS / BLOW-THRU ELECTRIC HEAT

Notes:

1. All dimensions are inches [millimeters] +/- 1/4" [6mm]. Metric values are soft conversions.
2. Left hand unit shown. Motor/drive location may be specified Left or Right Hand. Standard control enclosure location matches motor/drive position
3. Provide sufficient clearance to access electrical controls and comply with all applicable codes and ordinances
4. Optional base rail designed for use with floor mount vibration isolators
5. Blow-thru electric heat may not be combined with supply plenum or discharge section

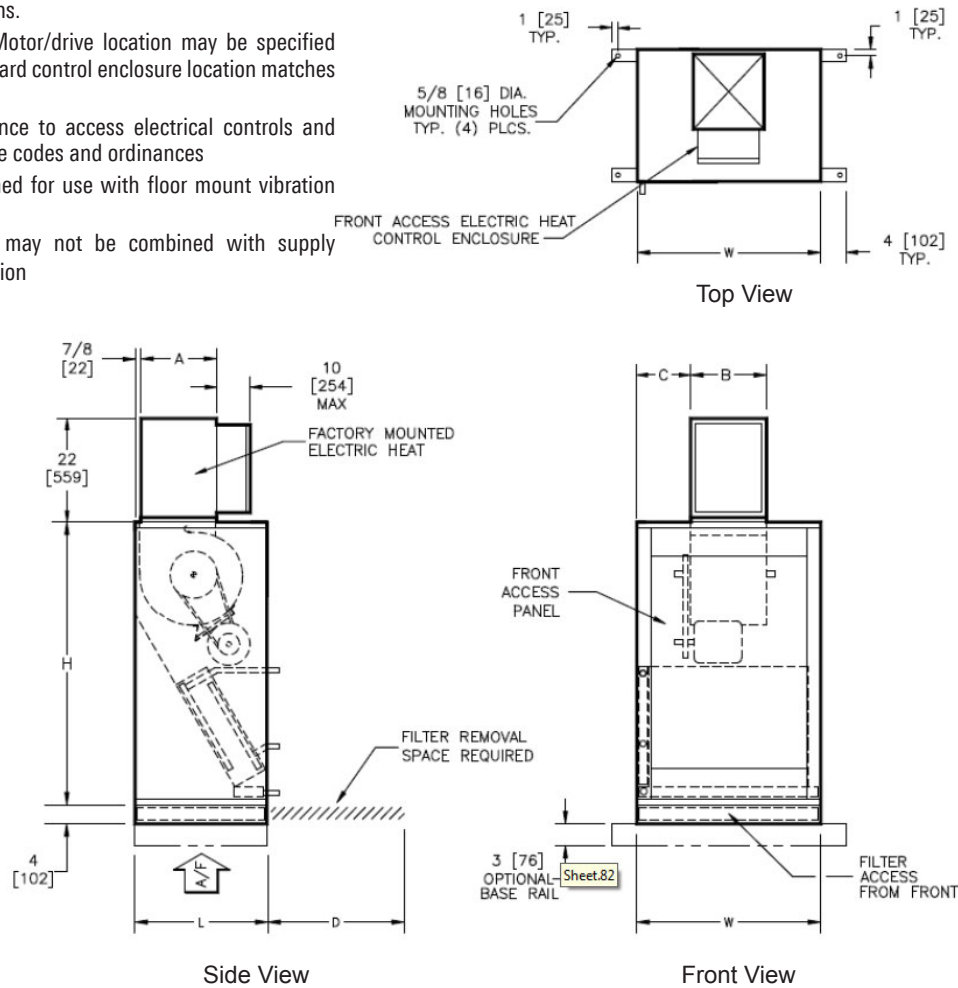

| Dimensions |                                 |        |           |          |          |              |              |               |          |
|------------|---------------------------------|--------|-----------|----------|----------|--------------|--------------|---------------|----------|
| Unit Size  | Filter Size                     | Qty    | H         | W        | L        | A            | B            | C             | D        |
| 08         | 16 x 20 x 2<br>[406 x 508 x 51] | 1      | 46 [1168] | 26 [660] | 19 [483] | 8 7/8 [226]  | 11 7/8 [302] | 7 1/16 [180]  | 16 [406] |
| 12         | 20 x 20 x 2<br>[508 x 508 x 51] | 1      | 46 [1168] | 26 [660] | 21 [533] | 8 7/8 [226]  | 11 7/8 [302] | 7 1/16 [180]  | 20 [508] |
| 16         | 24 x 24 x 2<br>[610 x 610 x 51] | 1      | 54 [1372] | 29 [737] | 25 [635] | 10 7/8 [277] | 12 [305]     | 8 1/2 [216]   | 24 [610] |
| 20         | 24 x 24 x 2<br>[610 x 610 x 51] | 1      | 54 [1372] | 29 [737] | 28 [711] | 13 7/8 [353] | 14 [356]     | 7 1/2 [190]   | 24 [610] |
| 25         | 24 x 24 x 2<br>[610 x 610 x 51] | 1 Each | 60 [1524] | 39 [991] | 28 [711] | 13 7/8 [353] | 16 5/8 [422] | 11 1/16 [281] | 24 [610] |
| 30         | 12 x 24 x 2<br>[305 x 610 x 51] | 1 Each | 60 [1524] | 39 [991] | 28 [711] | 15 5/8 [397] | 16 5/8 [422] | 11 1/16 [281] | 24 [610] |

