

THHC FREE RETURN UNIT DIMENSIONS

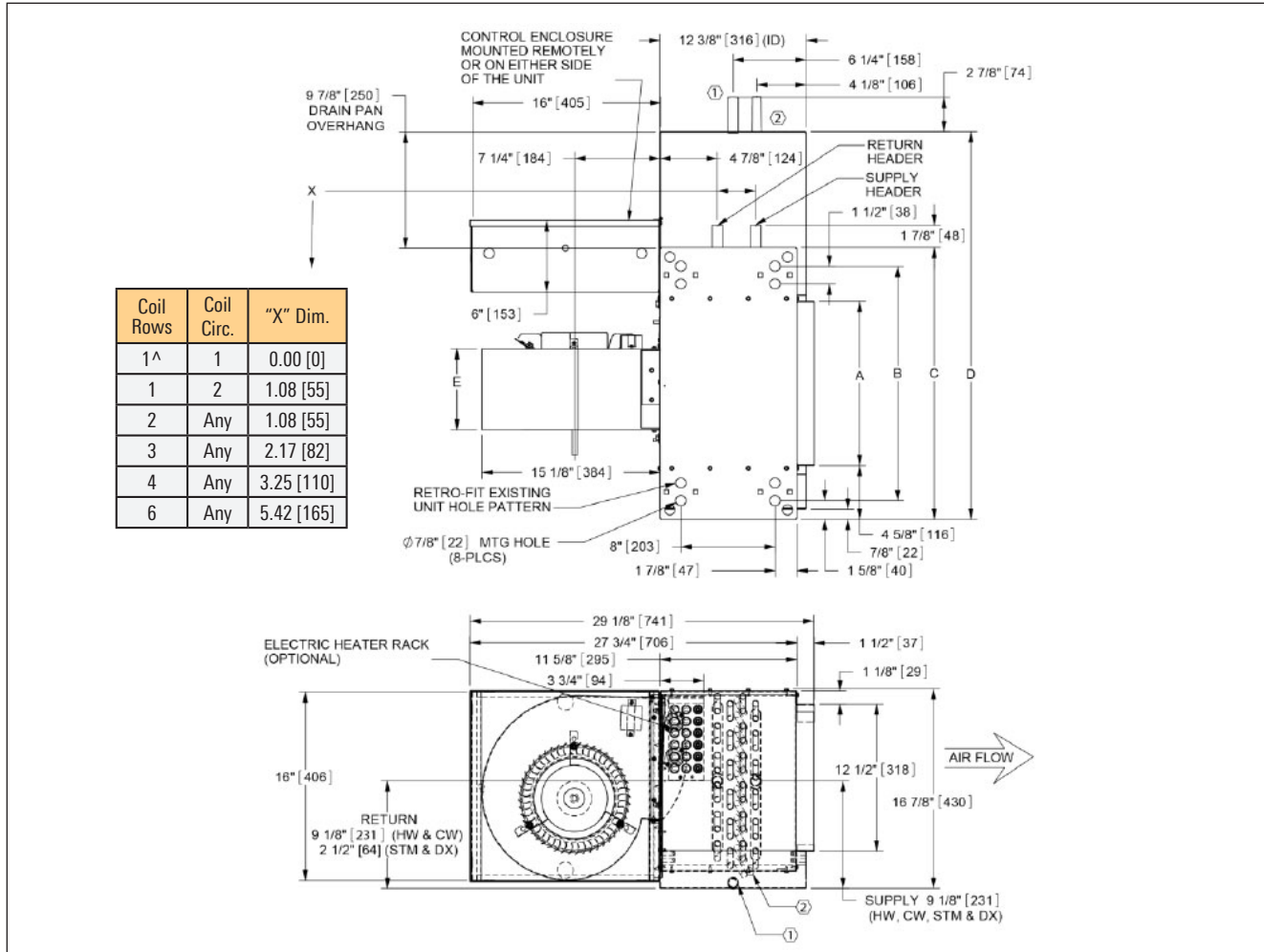

Coil Rows	Coil Circ.	"X" Dim.
1 [^]	1	0.00 [0]
1	2	1.08 [55]
2	Any	1.08 [55]
3	Any	2.17 [82]
4	Any	3.25 [110]
6	Any	5.42 [165]

Drain Pan Material	Single Connection (STD)	Secondary Connection (OPT)
Galvanized (STD)	7/8" OD Copper	5/8" OD Copper
Stainless (OPT)	3/4" MPT Galv.	1/2" MPT Galv.

Control Enclosure Sizes	
10 x 16 x 6	[250 x 406 x 152]
16 x 16 x 6	[406 x 406 x 152]

Unit Size	Fan Qty	A	B	C	D	E
06	1	14 [356]	20 [508]	23 1/8 [587]	34 [864]	6 7/8 [175]
08	1	19 [483]	25 [635]	28 1/8 [714]	39 [991]	8 1/4 [210]
10	1	23 [584]	29 [737]	32 1/8 [816]	43 [1092]	8 1/4 [210]
12	2	28 [711]	34 [864]	37 1/8 [943]	48 [1219]	6 7/8 [175]
14	2	33 [838]	39 [991]	42 1/8 [1070]	53 [1346]	8 1/4 [210]
16	2	38 [965]	44 [1118]	47 1/8 [1197]	58 [1473]	8 1/4 [210]
18	2	43 [1092]	49 [1245]	52 1/8 [1324]	63 [1600]	8 1/4 [210]
20	2	47 [1194]	53 [1346]	56 1/8 [1426]	67 [1702]	8 1/4 [210]

Notes:

- Standard control enclosure is mounted on unit side opposite cooling coil connections. Unit casing includes (2) knockouts on each side. Provide sufficient clearance to access electrical controls and comply with applicable codes and ordinances.
- Optional bottom control enclosure with hinged cover replaces standard side mounted enclosure and includes (2) additional knockouts on bottom of unit on left side
- Standard externally foam coated galvanized steel drain pan has 7/8" ODM copper outlet. Stainless steel drain pan has 3/4" MPT galvanized steel outlet.
- Auxiliary drain outlet is 5/8" ODM copper or 3/8" MPT galvanized steel respectively

THHC FREE RETURN UNIT DIMENSIONS

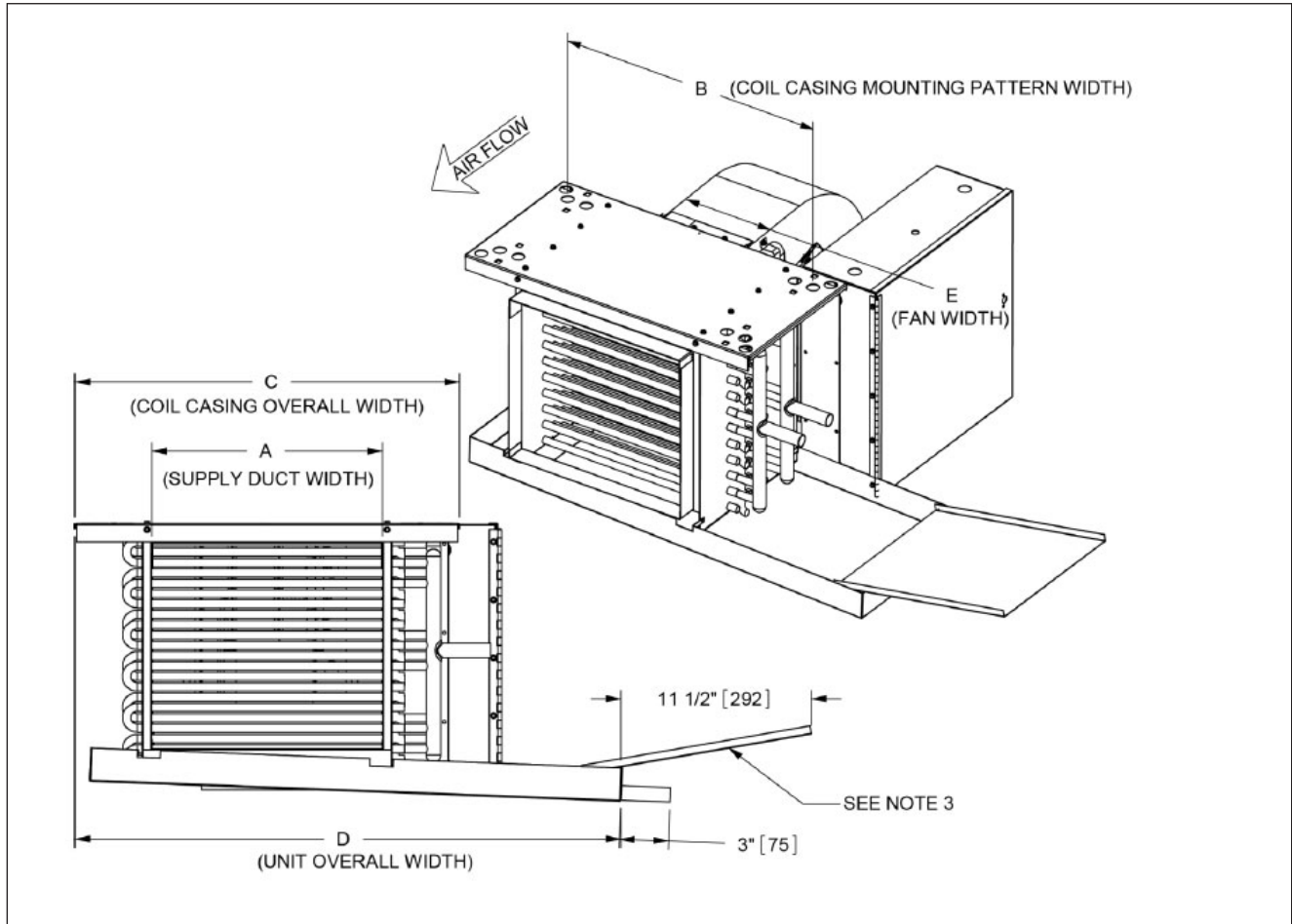

Notes:

1. All dimensions are inches [millimeters]. All dimensions $\pm 1/8"$ [6mm].
2. Drain pan is field reversible 180 and externally insulated
3. Optional auxiliary drip pan available for piping package condensate
4. Coil hand is field reversible (Left hand unit shown)

