

THBP UNIT DIMENSIONS

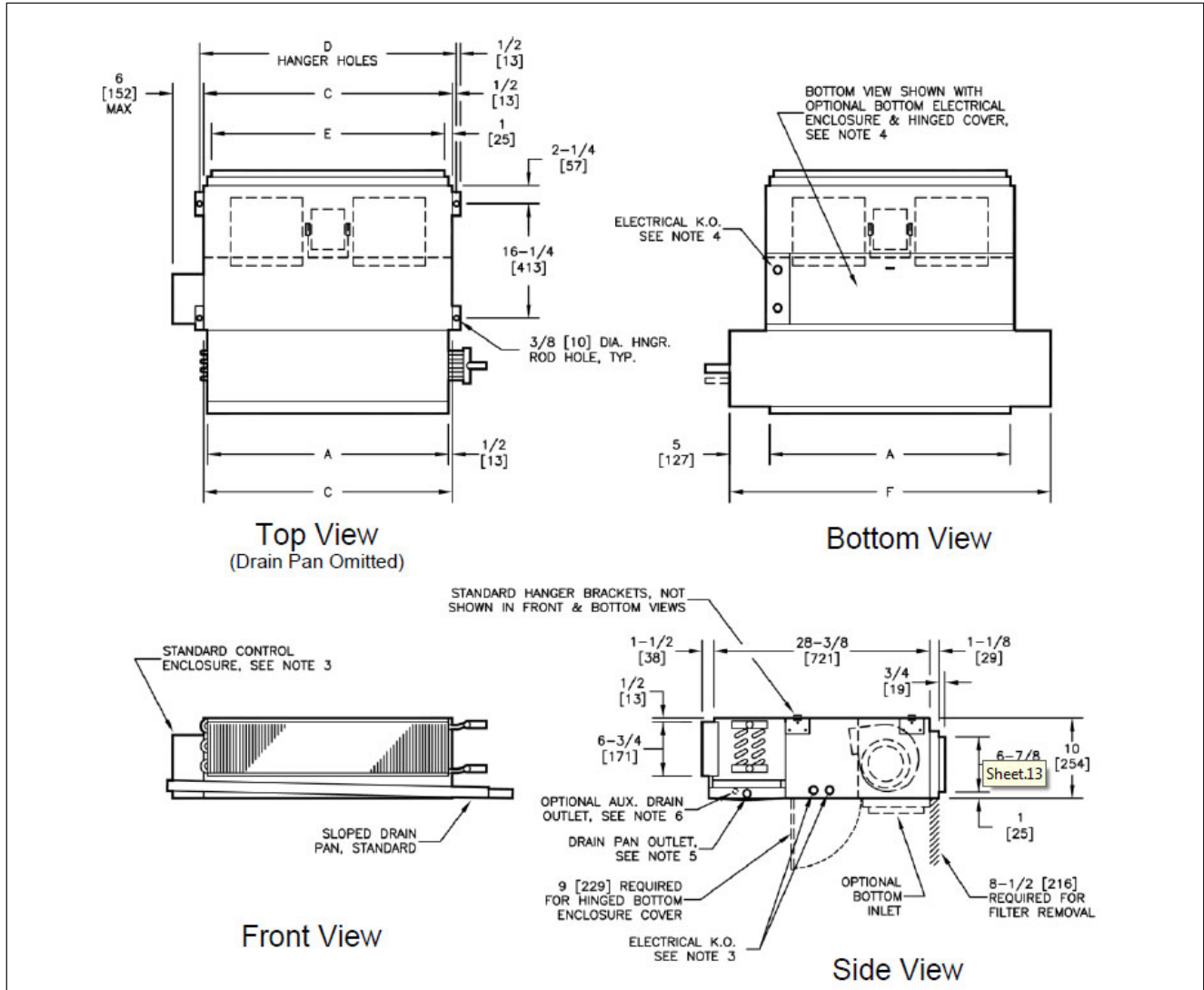

Dimensions					
Unit Size	A	C	D	E	F
20	20 [508]	21 [533]	22 [559]	19 [483]	30 [762]
25	26 [660]	27 [686]	28 [711]	25 [635]	36 [914]
30	30 [762]	31 [787]	32 [813]	29 [737]	40 [1016]
40	40 [1016]	41 [1041]	42 [1067]	39 [991]	50 [1270]
50	50 [1270]	51 [1295]	52 [1321]	49 [1245]	60 [1524]
60	60 [1524]	61 [1549]	62 [1575]	59 [1499]	70 [1778]

Notes:

1. All dimensions are inches [millimeters]. All dimensions  $\pm 1/4"$  [6mm]. Metric values are soft conversion.
2. Left hand unit shown, right hand unit opposite
3. Standard control enclosure is mounted on unit side opposite cooling coil connections. Unit casting includes (2) knockouts on each side Provide sufficient clearance to access electrical controls and comply with applicable codes and ordinances.
4. Optional bottom control enclosure with hinged cover replaces standard side mounted enclosure and includes (2) additional knockouts on bottom of unit, on left side
5. Standard externally foam coated galvanized steel drain pan has 7/8" ODM cooper outlet. Stainless steel drain pan has 3/4" MPT galvanized steel outlet.
6. Aux. drain outlet is 5/8" ODM cooper or 3/8" MPT galvanized steel respectively
7. See coil connection drawings for coil connection sizes and locations