

S301 / S300 (FL / FS) DIMENSIONS

Height	Min : Max Duct Diameter
3"	6" : 36"
4"	8" : 36"
6"	10" : 36"
8"	12" : 36"
10"	14" : 36"
12"	16" : 36"

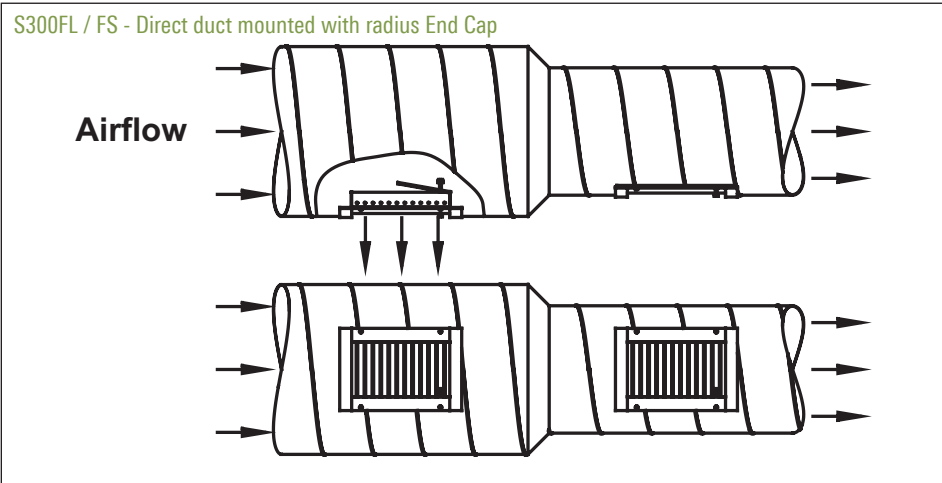
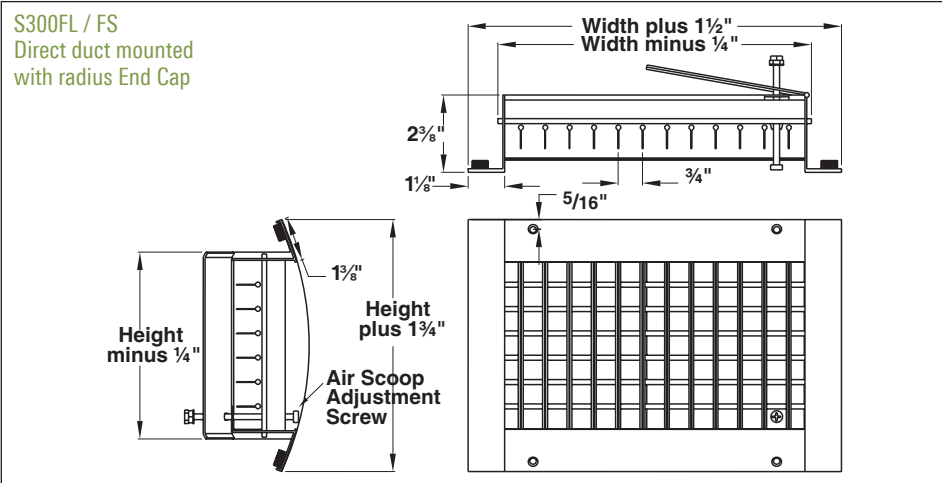
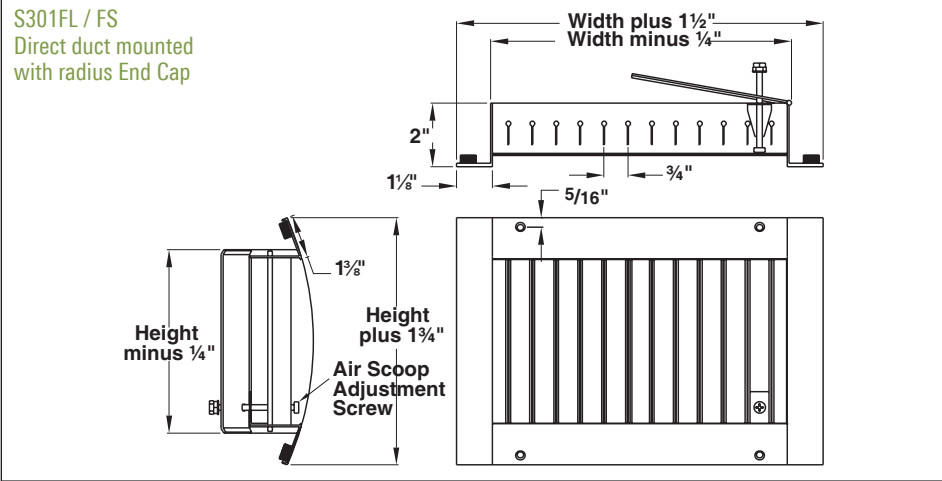

Application Note: For duct velocities up to 800 fpm, the damper/extractor is not required. For duct velocities higher than 800 fpm, the damper/extractor is recommended.