

US301 / US300 (FL / FS) DIMENSIONS

Height	Min : Max Duct Diameter
3"	10" : 36"
4"	10" : 36"
6"	12" : 36"
8"	20" : 36"
10"	24" : 36"

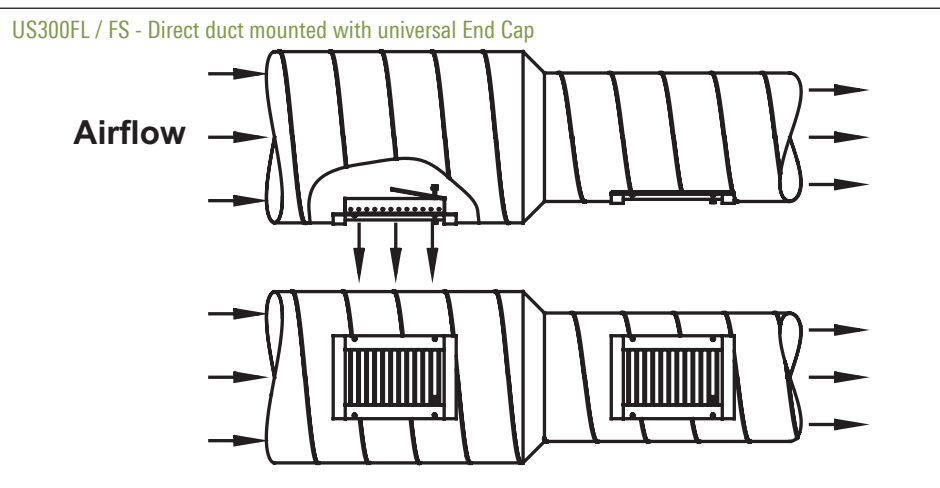
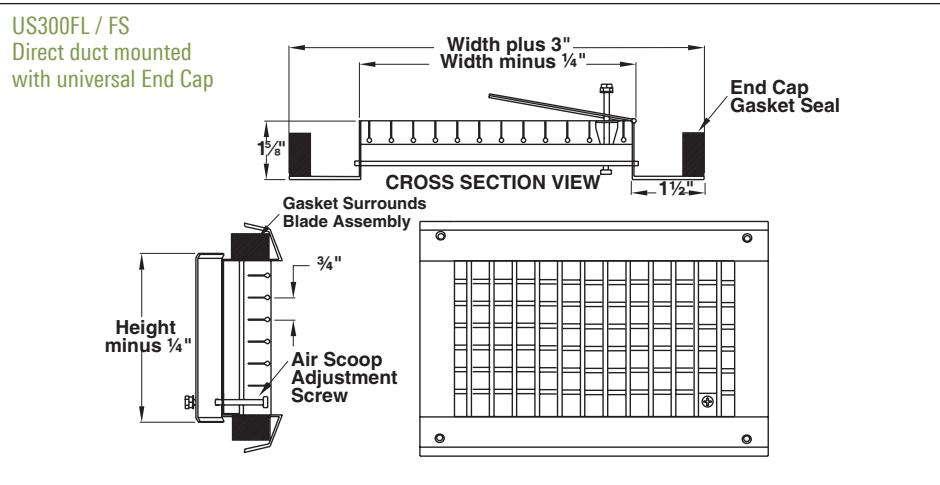
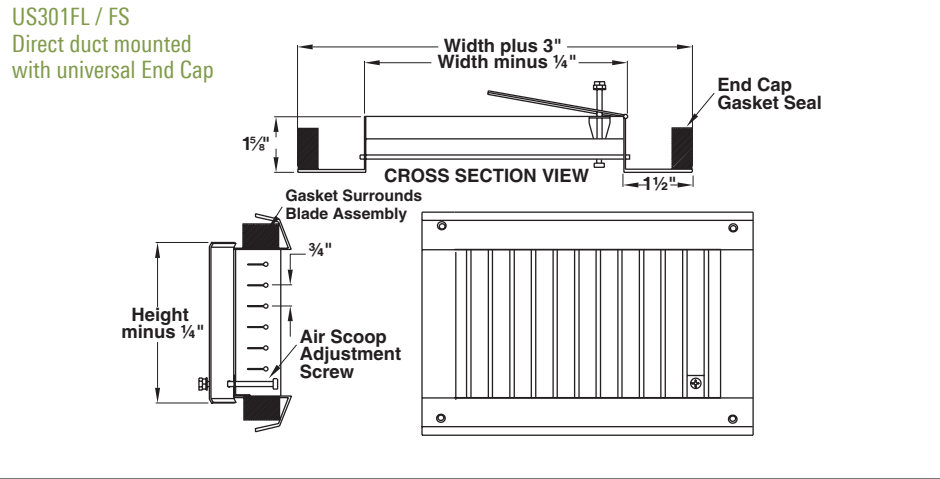

Application Note: For duct velocities up to 800 fpm, the damper/extractor is not required. For duct velocities higher than 800 fpm, the damper/extractor is recommended.