

Perforated Return Grilles and Registers Aluminum Borders • Aluminum Perforated Face

Model: M8F

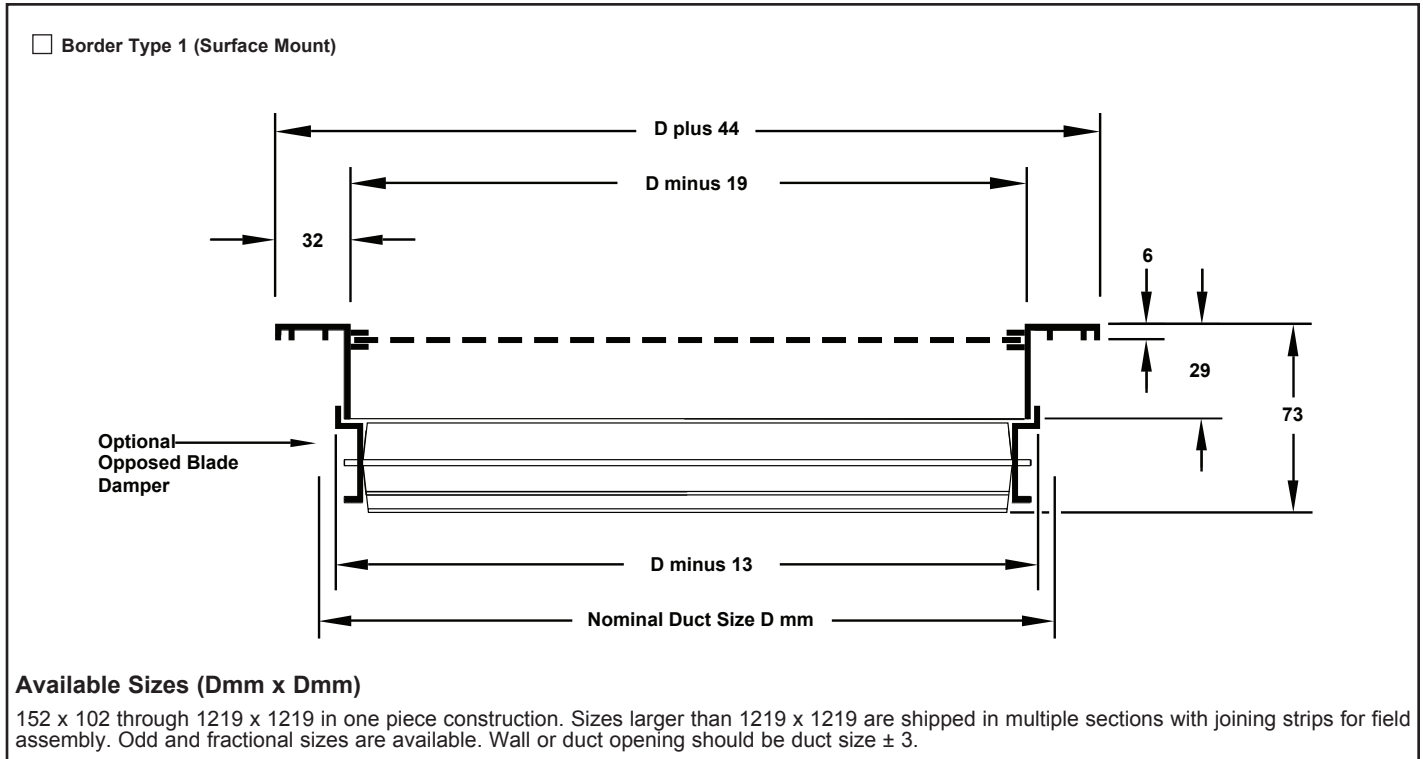

Fasteners

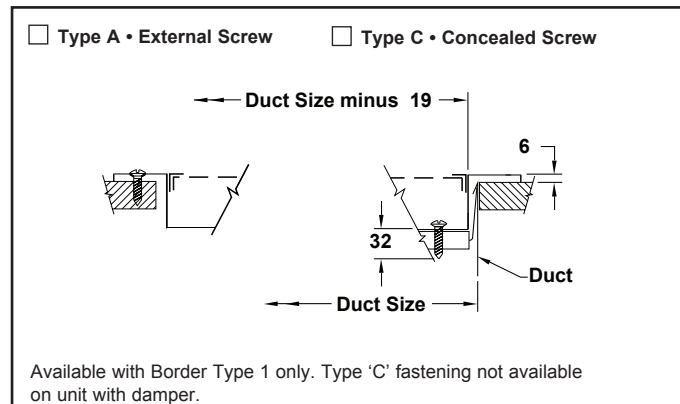

Mounting Frames

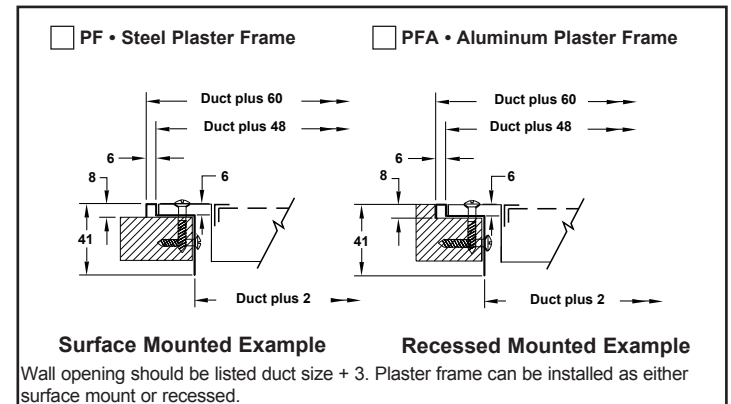

Accessories (Optional) Check if provided

- Neck mounted opposed blade damper (galvanized steel)
- IS • Insect Screen (2mm square mesh – galvanized steel)
- DS • Debris Screen (6mm square mesh – galvanized steel)
- EQT • Earthquake tabs
- Other _____

Standard Finish: #26 White

- Optional finish _____

General Description

- Models M8F provides a smooth, perforated face that fits flush with the ceiling to blend with the room decor.
- 5mm staggered holes on 6mm centers.
- 51% free area.
- Optional opposed blade damper has screw-driver adjustment accessible through face of register.
- Material is aluminum border with aluminum perforated face.

Optional Border Types Available

**Border Type 2 (Snap-in)
Panel Mounted**

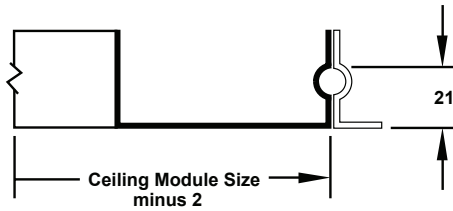

Available in 610 x 610 modules with neck sizes up to 508 x 508.

**Border Type 3 (Lay-in)
Panel Mounted**

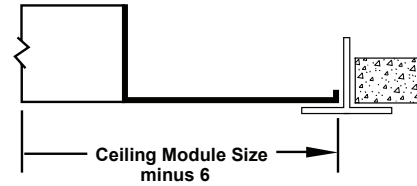

Available in all standard module sizes with neck sizes up to module size minus 51.

**Border Type 4 (Spline)
Panel Mounted**

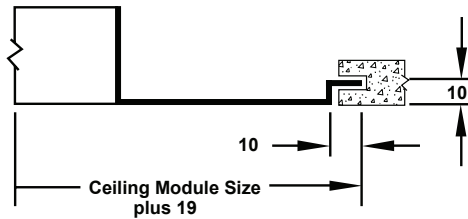

Available in 610 x 610 modules with neck sizes up to 508 x 508.
Splines on 2 opposite sides only

Border Type 2, 3, 4

• **Accessories & Options**

Check if provided

- Neck mounted opposed blade damper (galvanized steel)
- IS • Insect Screen (2mm square mesh – galvanized steel)
- DS • Debris Screen (6mm square mesh – galvanized steel)
- EQT • Earthquake tabs
- Other _____

Standard Finish: #26 White



Note: This submittal is meant to demonstrate general dimensions of this product. The drawings on this submittal are not meant to detail every aspect of the product with exactness. Drawings are not to scale. TITUS reserves the right to make changes without written notice.
605 Shiloh Road • Plano, Texas 75074 • 972-212-4800

MSPG-8.0-S