

## Linear Bar Diffusers Aluminum • Fixed Bars

- Models: **MCT-480** • 6mm Spacing • 3mm Bars • 0° Deflection  
**MCT-481** • 6mm Spacing • 3mm Bars • 15° Deflection  
**MCT-580** • 13mm Spacing • 3mm Bars • 0° Deflection  
**MCT-581** • 13mm Spacing • 3mm Bars • 15° Deflection  
**MCT-540** • 13mm Spacing • 6mm Bars • 0° Deflection  
**MCT-541** • 13mm Spacing • 6mm Bars • 15° Deflection

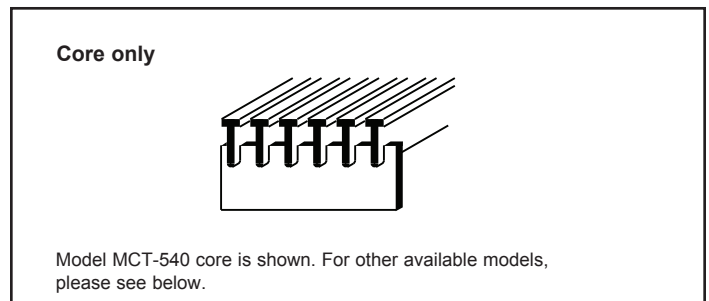
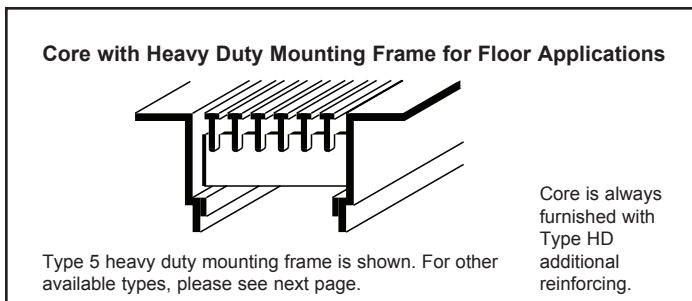
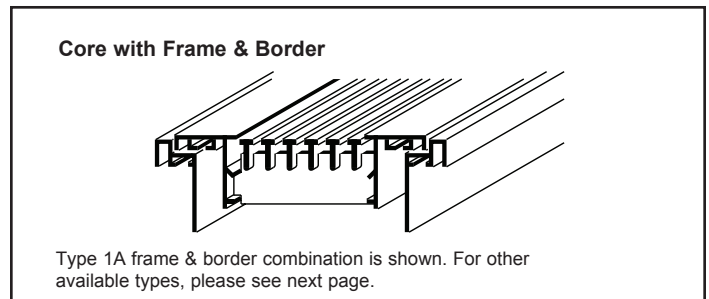
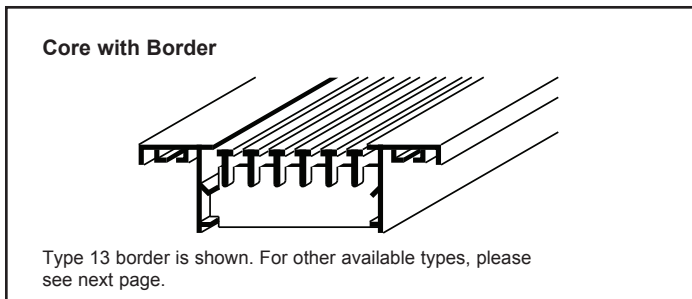

### Available Cores selection

6mm Spacing		13mm Spacing	
3mm Bars		3mm Bars	6mm Bars
<input type="checkbox"/> <b>Model MCT-480 • 0° Deflection</b> 		<input type="checkbox"/> <b>Model MCT-580 • 0° Deflection</b> 	<input type="checkbox"/> <b>Model MCT-540 • 0° Deflection</b> 
<input type="checkbox"/> <b>Model MCT-481 • 15° Deflection</b> 		<input type="checkbox"/> <b>Model MCT-581 • 15° Deflection</b> 	<input type="checkbox"/> <b>Model MCT-541 • 15° Deflection</b> 

All dimensions are in millimeters.

† NOTE: Not recommended for floor applications with heavy loads or high traffic.

(Please see reverse side.)

# Frame & Border Types, Dimensions selection

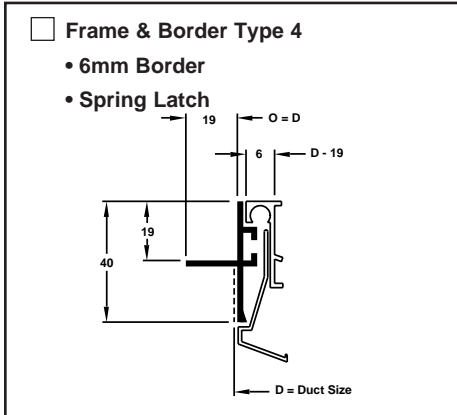
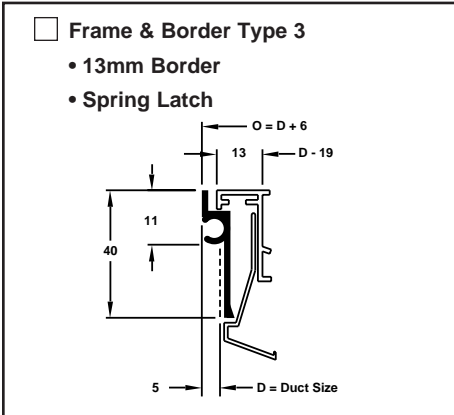
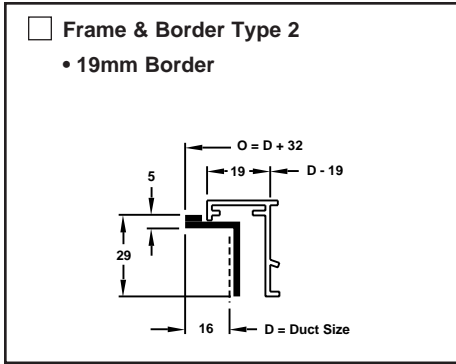
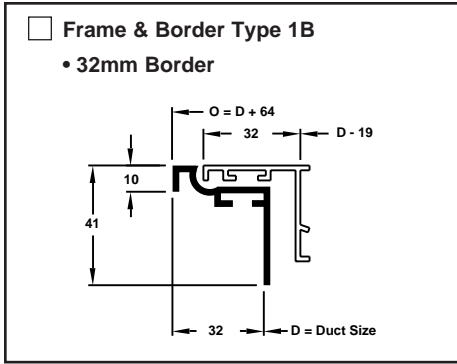
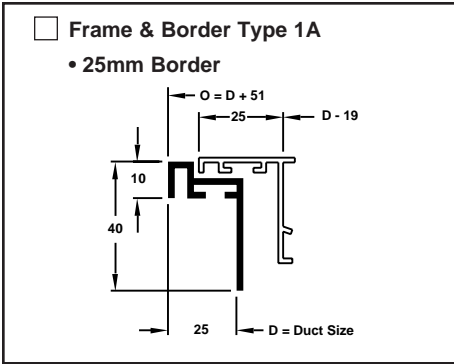

# Border Types, Dimensions selection

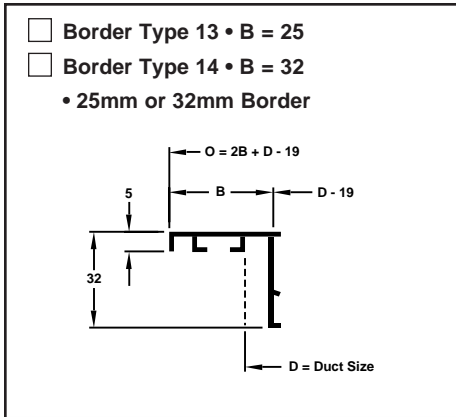
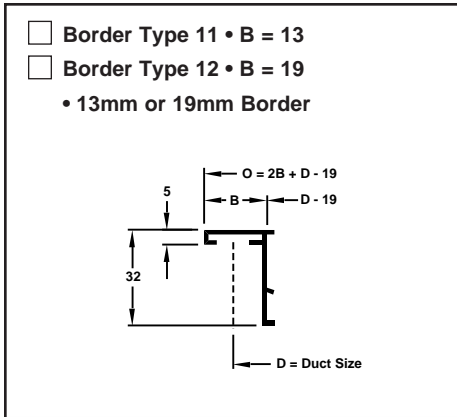
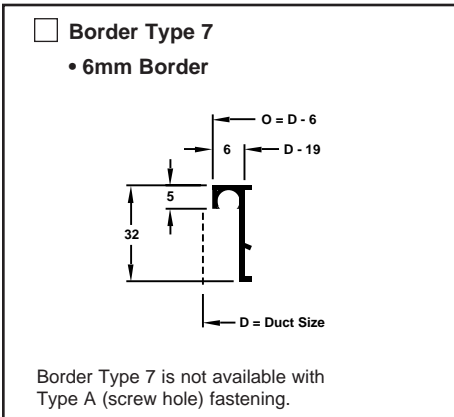

# Heavy Duty Mounting Frames for Floor Applications selection

(See submittal MD-MCT-HD for loading limitations.)

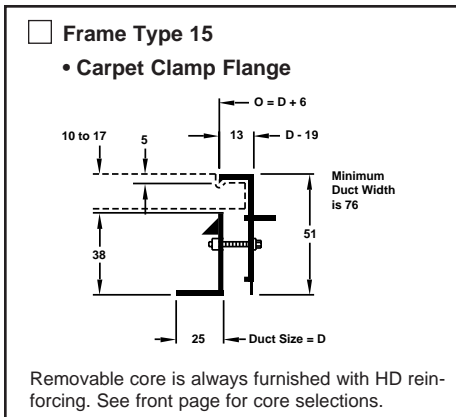
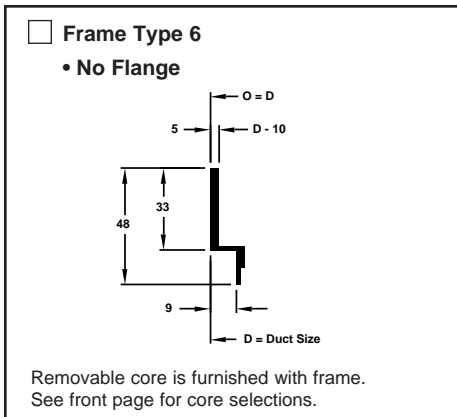
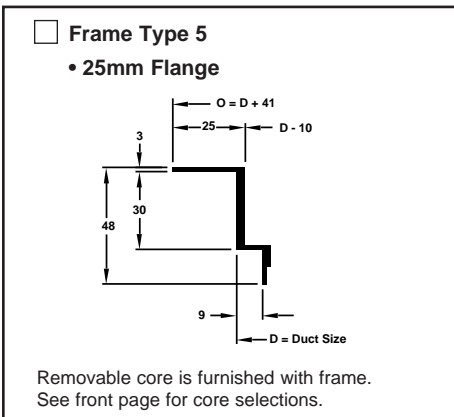

# Core Only (No Frame, No Border) Type CO

# Overall Lengths and Widths for Various Frame & Border Types

**Border Types (Type 11 Shown)**

Type	F Border Length	O Overall Length	C Core Opening Length
5	D	D plus 41	D minus 10
6	D	D	D minus 10
7	D minus 16	D minus 6	D minus 19
11	D minus 16	D plus 6	D minus 19
12	D minus 16	D plus 19	D minus 19
13	D minus 16	D plus 32	D minus 19
14	D minus 16	D plus 44	D minus 19

Dimensions are for length or width.

**Frame & Border Types (Type 1A & 1B Shown)**

Type	F Frame Length	O Overall Length	C Core Opening Length
1A	D	D plus 51	D minus 19
1B	D	D plus 64	D minus 19
2	D	D plus 32	D minus 19
3	D	D plus 6	D minus 19
4	D	D	D minus 19
15	D	D plus 6	D minus 19

Dimensions are for length or width.

## Standard Core Width Information

Duct Size D	6mm Spacing		13 or 11mm Spacing	
	Core Opening C	Number of Bars	Core Opening C	Number of Bars
38	19	1	19	1
51	32	3	32	2
64	44	5	44	3
76	57	7	57	4
89	70	9	70	5
102	83	11	83	6
127	108	15	108	8
152	133	19	133	10

**Core Only**

S=229" Maximum Support Bar Spacing.  
D=1829" Maximum for One Piece. *Core Only* is an option available for field framing. Standard widths are as shown. Core will ship 19mm smaller than the duct width.

## Alignment Strips

Used with border width 13mm or wider. Alignment wire used with 6mm borders.

## Available Fastenings

Check  selection

**Type A • Screw Holes**

For ceiling, side wall or sill. Used with Frame & Border Types 1B, 5, 11, 12, 13, 14.

**Type B • Spring Clip**

For sill installations. Used with Frame & Border Types 5, 6, 7, 11, 12, 13 and 14. Must use MAG-35B instead of MAG-35 with Type B fastening. Sill opening size must be slightly larger to accommodate spring clips.

**Type C • Concealed Fastening**

For ceiling, side wall or sill. Used with Frame & Border Types 1A, 1B, 2, 3, 4, 7, 11, 12, 13, 14.

## Additional Reinforcing (Optional)

Check  if provided

**Type HD • Optional Heavy Duty Core**  
• Standard with Heavy Duty Mounting Frame Types 5, 6, 15

Optional Heavy Duty Core has support bars on 152mm maximum centers. (Standard core has 229mm maximum centers.) See Submittal MCT-HD for maximum loading.

**Type C Concealed Fastening - Notes**

- Used without spring latch in Frame & Border Types 3 and 4.
- Not recommended for use with Cores MCT-480 and MCT-481 (6mm bar spacing). Screwdriver will not fit between bars.

# Accessories (Optional)

Check  if provided

**Model MM07 Directional**

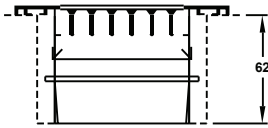

For all widths of Model MCT diffusers 76" or greater. Cannot be attached to Frame & Border Types 3 and 4. Can be used with Type 5, 6, 15 if Type B Spring Clip Fastening is omitted.

**Model MAG-30 Single Blade Damper**

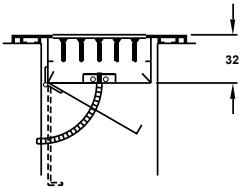

For Model MCT diffuser widths 38 through 102mm. Friction hinge on 38mm and 51mm widths. Screwdriver operator on 64mm through 102mm. Cannot be attached to Frame & Border Types 3, 4, 5, 6 or 15. For those types use Model MAG-35B damper on diffusers 76mm and wider.

**Model MAG-35 Opposed Damper**

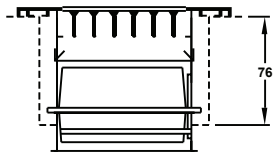

For Model MCT diffusers 76mm and wider. Not recommended for Models MCT-480 and MCT-481. Cannot be attached to Frame & Border Types 3 and 4. Use Model MAG-35 B damper for those types. Note: Minimum duct width is 3".

**Model MBLKS Steel Blank-Off**

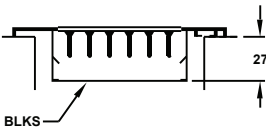

For all widths of Model MCT diffusers. Furnished in 1829mm foot lengths for field cutting and installation. Steel, painted flat black.

**Model MAD Access Door (Not Available on types 5, 6 and 15.)**

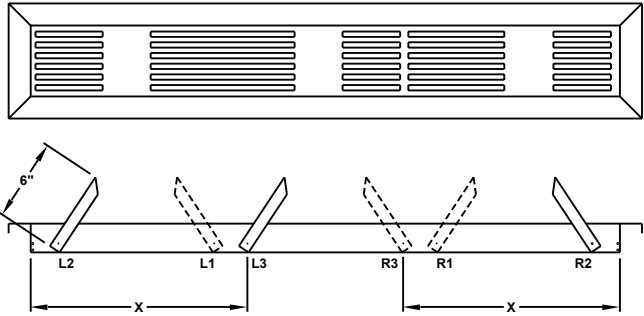

Note: Maximum Length is 1829

Specify Dimension X

**Optional Mitered Corners**

- MMC-480 • 6mm Spacing • 3mm Bars • 0° Deflection
- MMC-481 • 6mm Spacing • 3mm Bars • 15° Deflection
- MMC-580 • 13mm Spacing • 3mm Bars • 0° Deflection
- MMC-581 • 13mm Spacing • 3mm Bars • 15° Deflection
- MMC-540 • 13mm Spacing • 6mm Bars • 0° Deflection
- MMC-541 • 13mm Spacing • 6mm Bars • 15° Deflection

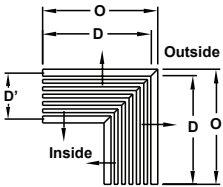

Floor, Ceiling or Sill

- Type O • 0° Deflection
- Type A • Deflection Inside
- Type B • Deflection Outside

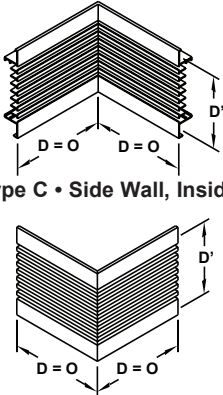

- Type C • Side Wall, Inside
- Type D • Side Wall, Outside

Overall Dimension O for Various Frame & Border Types

Duct Width D'	Duct Length D	Frame & Border Type														
		1A	1B	2	3	4	5	6	7	11	12	13	14	15	CO	
38-102	305	329	335	321	310	305	325	305	302	308	314	321	327	308	305	
105-152	406	481	487	473	462	457	478	457	454	460	467	473	479	460	457	

**Standard Finish:** #26 White

## General Description

- TITUS linear bar diffusers are designed for both supply and return applications.
- Standard lengths are 305, 610, 914, 1219, 1524 and 1829 mm, furnished as complete, welded assemblies

- Lengths greater than 1829mm are furnished in multiple sections, the number and size determined by the factory
- Sections can be joined end-to-end for continuous appearance, using standard alignment strips or alignment pins

- All deflection bars are fixed and are parallel to the long dimension
- Fixed bars are extruded aluminum
- Border Types 5, 6 and 15 are the only frame styles available for floor applications



Note: This submittal is meant to demonstrate general dimensions of this product. The drawing on this submittal are not meant to detail every aspect of the product with exactness. Drawings are not to scale. TITUS reserves the right to make changes without written notice.

605 Shiloh Road • Plano, Texas 75074 • 972-212-4800

MD-4.0-S