

Air Balancing Devices Damper with Grid • Duct Mounted For Round Duct Takeoffs

Model: AG-65

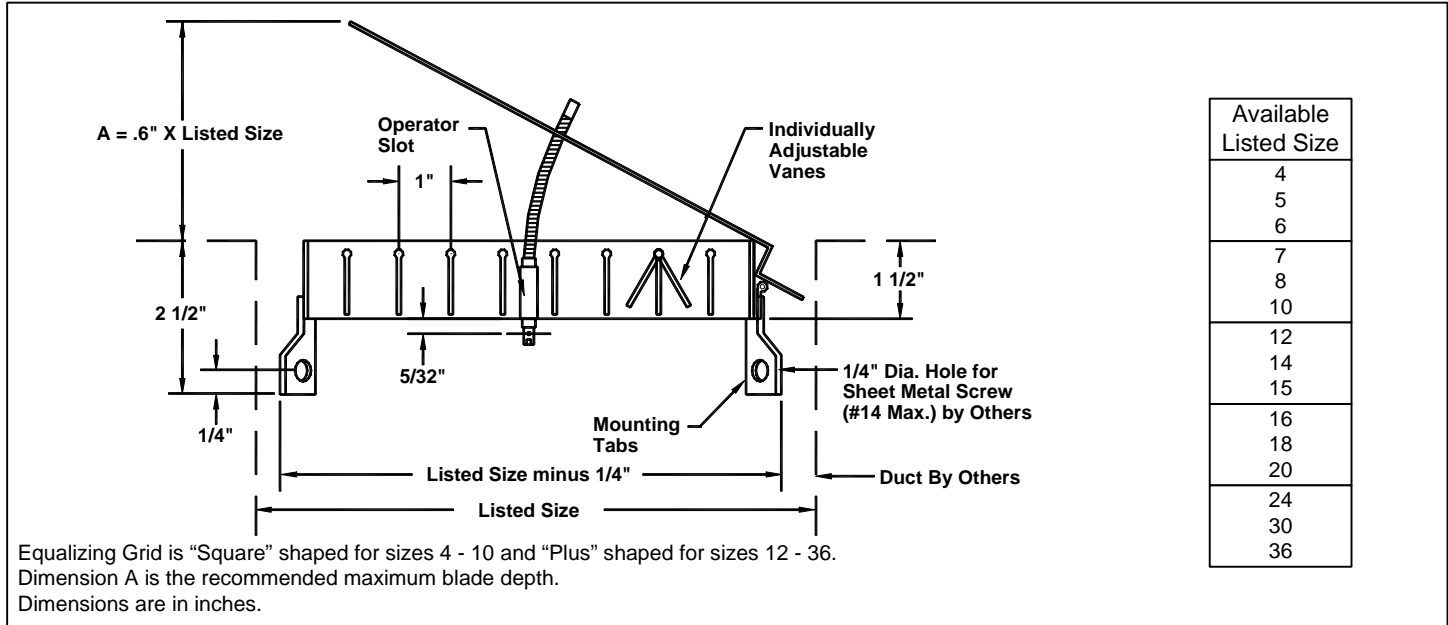

Installation Detail

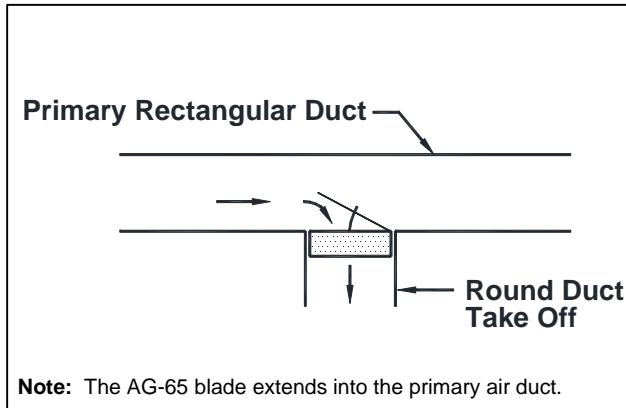

AG-65 Detail



Standard Finish: #84 Black

General Description

- The TITUS AG-65 is a duct mounted damper with grid used in round duct applications.
- Performs as a turning vane, damper and equalizing grid.
- Field installs at the transition between the primary rectangular duct and the round duct take off.
- Damper blade is adjustable at screwdriver operator slot located in round duct section. Blade opens directly into primary air system.
- Material is heavy gauge steel.

This submittal is meant to demonstrate general dimensions of this product. The drawings are not meant to detail every aspect of the product. Drawings are not to scale. Titus reserves the right to make changes without written notice.

All rights reserved. No part of this work may be reproduced or transmitted in any form or by any means, electronic or mechanical, including photocopying and recording, or by any information storage retrieval system without permission in writing from Air Distribution Technologies.