

DIMENSIONS

TMSA / TMSA-AA UNIT DIMENSIONS

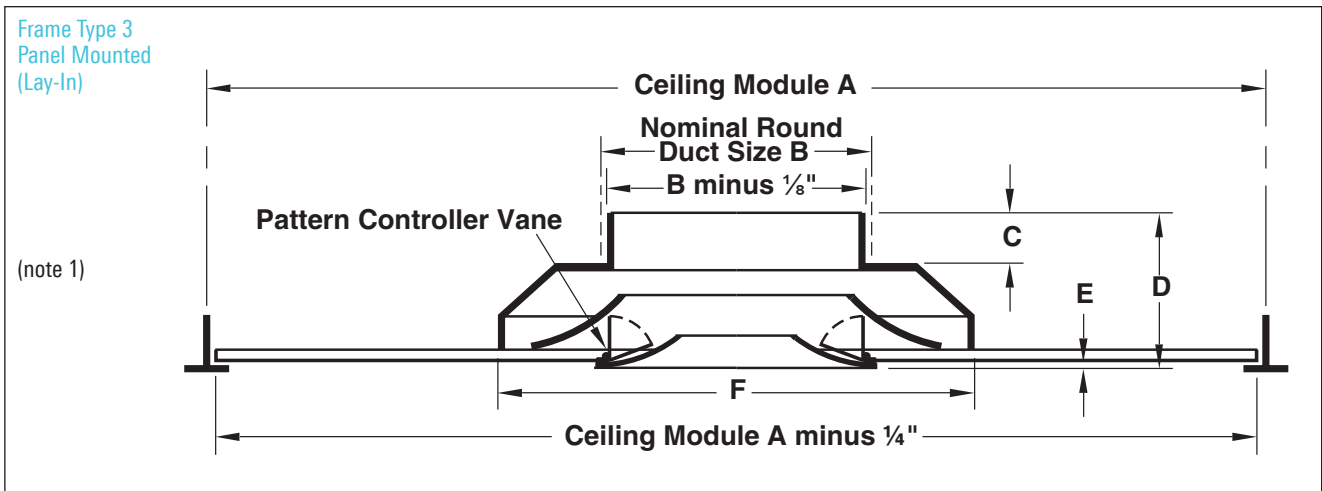
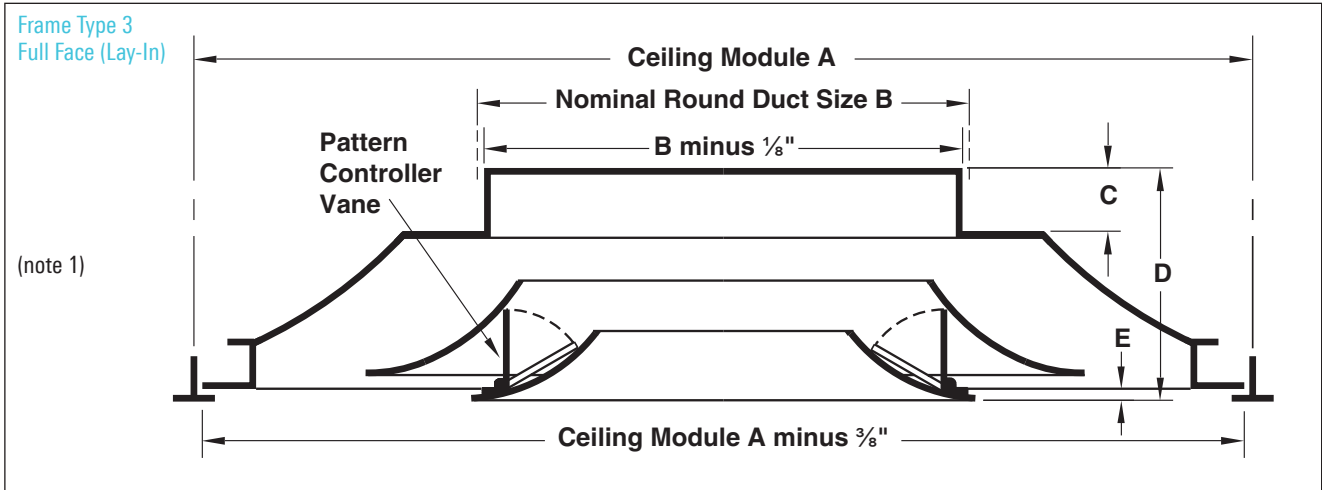

Ceiling Module A	Nominal Round Duct Size B	C	D	E
12 x 12	4, 5 (note 2)	3 <sup>1</sup> / <sub>8</sub>	5 <sup>3</sup> / <sub>8</sub>	3 <sup>3</sup> / <sub>8</sub>
12 x 12	6, 7 (note 3)	1 <sup>1</sup> / <sub>8</sub>	3 <sup>3</sup> / <sub>8</sub>	3 <sup>3</sup> / <sub>8</sub>
12 x 12	8	1 <sup>1</sup> / <sub>4</sub>	3 <sup>1</sup> / <sub>2</sub>	5 <sup>5</sup> / <sub>8</sub>
20 x 20	4, 5*	2 <sup>3</sup> / <sub>4</sub>	6 <sup>3</sup> / <sub>8</sub>	1 <sup>1</sup> / <sub>4</sub>
20 x 20	6, 8, 10	3 <sup>3</sup> / <sub>4</sub>	4 <sup>3</sup> / <sub>8</sub>	1 <sup>1</sup> / <sub>4</sub>
24 x 24	6, 8	1 <sup>1</sup> / <sub>4</sub>	5	1 <sup>1</sup> / <sub>4</sub>
24 x 24	10, 12, 14, 15	1 <sup>3</sup> / <sub>8</sub>	5 <sup>1</sup> / <sub>8</sub>	1 <sup>1</sup> / <sub>4</sub>

Ceiling Module A	Nominal Round Duct Size B	Nominal Face Size F	C	D	E
24 x 24	4, 5 (note 2)	12 x 12	3 <sup>1</sup> / <sub>8</sub>	5 <sup>3</sup> / <sub>8</sub>	3 <sup>3</sup> / <sub>8</sub>
24 x 24	6, 7 (note 3)	12 x 12	1 <sup>1</sup> / <sub>8</sub>	3 <sup>3</sup> / <sub>8</sub>	3 <sup>3</sup> / <sub>8</sub>
24 x 24	8	12 x 12	1 <sup>1</sup> / <sub>4</sub>	3 <sup>1</sup> / <sub>2</sub>	5 <sup>5</sup> / <sub>8</sub>

Notes:

1. Aluminum construction is available in full face 24" x 24" ceiling module only. Steel construction is available in all sizes.
2. Adapter is provided for sizes 4 and 5
3. The smallest neck size available in aluminum is 6 inches