

Redefine your comfort zone.™ | www.titus-hvac.com

## TDC - SQUARE NECK / LOUVERED FACE / SUPPLY / HORIZONTAL BLOW PATTERN

		Neck Vel.	300	400	500	600	700	800	900
		Vel. Pressure	0.006	0.010	0.016	0.022	0.031	0.040	0.050
		Total Pressure	0.042	0.075	0.117	0.169	0.229	0.300	0.379
Return Factors -SP = 1.1 TP NC + 1		Total cfm NC Side	75	100	125	150	175	200	225
		cfm Throw	-	13	16	23	27	31	34
6 x 6 0.25 ft²	S1	X	75	100	125	150	175	200	225
	S2&G2	X & Y	38	50	63	75	88	100	113
	A3	X	28	38	47	56	66	75	84
	A4	X & Y	19	25	31	38	44	50	56
Return Factors -SP = 1.1 TP NC + 1		Total cfm NC Side	169	225	281	338	394	450	506
		cfm Throw	-	15	21	26	30	34	37
9 x 9 0.56 ft²	S1	X	169	225	281	338	394	450	506
	S2&G2	X & Y	84	113	141	169	197	225	253
	A3	X	63	84	105	127	148	169	190
	A4	X & Y	42	56	70	84	98	113	127
Return Factors -SP = 1.1 TP NC + 1		Total cfm NC Side	300	400	500	600	700	800	900
		cfm Throw	-	17	23	28	32	35	38
12 x 12 1.00 ft²	S1	X	300	400	500	600	700	800	900
	S2&G2	X & Y	150	200	250	300	350	400	450
	A3	X	113	150	188	225	263	300	338
	A4	X & Y	75	100	125	150	175	200	225
Return Factors -SP = 1.1 TP NC + 1		Total cfm NC Side	469	625	781	938	1094	1250	1406
		cfm Throw	11	19	25	29	33	37	40
15 x 15 1.56 ft²	S1	X	469	625	781	938	1094	1250	1406
	S2&G2	X & Y	234	313	391	469	547	625	703
	A3	X	176	234	293	352	410	469	527
	A4	X & Y	117	156	195	234	273	313	352
Return Factors -SP = 1.1 TP NC + 1		Total cfm NC Side	675	900	1125	1350	1575	1800	2025
		cfm Throw	12	20	26	31	35	38	41
18 x 18 2.25 ft²	S1	X	675	900	1125	1350	1575	1800	2025
	S2&G2	X & Y	338	450	563	675	788	900	1013
	A3	X	253	338	422	506	591	675	759
	A4	X & Y	169	225	281	338	394	450	506
Return Factors -SP = 1.1 TP NC + 1		Total cfm NC Side	919	1225	1531	1838	2144	2450	2756
		cfm Throw	13	21	27	32	36	39	42
21 x 21 3.06 ft²	S1	X	919	1225	1531	1838	2144	2450	2756
	S2&G2	X & Y	459	613	766	919	1072	1225	1378
	A3	X	345	459	574	689	804	919	1034
	A4	X & Y	230	306	383	459	536	613	689
Return Factors -SP = 1.1 TP NC + 1		Total cfm NC Side	1200	1600	2000	2400	2800	3200	3600
		cfm Throw	14	22	28	32	36	40	43
24 x 24 4.00 ft²	S1	X	1200	1600	2000	2400	2800	3200	3600
	S2&G2	X & Y	600	800	1000	1200	1400	1600	1800
	A3	X	450	600	750	900	1050	1200	1350
	A4	X & Y	300	400	500	600	700	800	900
Return Factors -SP = 1.1 TP NC + 1		Total cfm NC Side	1875	2500	3125	3750	4375	5000	5625
		cfm Throw	16	23	29	34	38	41	45
30 x 30 6.25 ft²	S1	X	1875	2500	3125	3750	4375	5000	5625
	S2&G2	X & Y	938	1250	1563	1875	2188	2500	2813
	A3	X	703	938	1172	1406	1641	1875	2109
	A4	X & Y	469	625	781	938	1094	1250	1406
Return Factors -SP = 1.1 TP NC + 1		Total cfm NC Side	2700	3600	4500	5400	6300	7200	8100
		cfm Throw	17	24	30	35	39	43	46
36 x 36 9.00 ft²	S1	X	2700	3600	4500	5400	6300	7200	8100
	S2&G2	X & Y	1350	1800	2250	2700	3150	3600	4050
	A3	X	1013	1350	1688	2025	2363	2700	3038
	A4	X & Y	675	900	1125	1350	1575	1800	2025
Return Factors -SP = 1.1 TP NC + 1		Total cfm NC Side	4800	6400	8000	9600	11200	12800	14400
		cfm Throw	19	26	32	37	41	45	48
48 x 48 16.00 ft²	S1	X	4800	6400	8000	9600	11200	12800	14400
	S2&G2	X & Y	2400	3200	4000	4800	5600	6400	7200
	A3	X	1800	2400	3000	3600	4200	4800	5400
	A4	X & Y	1200	1600	2000	2400	2800	3200	3600

Performance notes appear at end of performance data

TDC - RECTANGULAR NECK / LOUVERED FACE / SUPPLY / HORIZONTAL BLOW PATTERN

		Neck Vel. Vel. Pressure Total Pressure	300 0.006 0.042	400 0.010 0.075	500 0.016 0.117	600 0.022 0.169	700 0.031 0.229	800 0.040 0.300	900 0.050 0.379	
6 x 9 0.38 ft²	Return Factors -SP = 1.1 TP NC + 1	Total cfm NC Side	113 - -	150 14 -	188 20 -	225 25 -	263 29 -	300 32 -	338 35 -	
	A1&B1	X	113	150	188	225	263	300	338	
	A2&B2	X & Y	56	75	94	113	131	150	169	
	E2&F2	X	75	100	125	150	175	200	225	
		Y	38	50	63	75	88	100	113	
	A3	X	47	63	78	94	109	125	141	
		Y	19	25	31	38	44	50	56	
	A3-2	X	42	56	70	84	98	113	127	
		Y	35	47	59	70	82	94	105	
	B4	X	38	50	63	75	88	100	113	
		Y	19	25	31	38	44	50	56	
	6 x 12 0.50 ft²	Return Factors -SP = 1.1 TP NC + 1	Total cfm NC Side	150 - -	200 15 -	250 21 -	300 26 -	350 30 -	400 33 -	450 36 -
		A1&B1	X	150	200	250	300	350	400	450
		A2&B2	X & Y	75	100	125	150	175	200	225
E2&F2		X	113	150	188	225	263	300	338	
		Y	38	50	63	75	88	100	113	
A3		X	66	88	109	131	153	175	197	
		Y	19	25	31	38	44	50	56	
B3		X	75	100	125	150	175	200	225	
		Y	38	50	63	75	88	100	113	
B4		X	56	75	94	113	131	150	169	
		Y	19	25	31	38	44	50	56	
6 x 15 0.63 ft²		Return Factors -SP = 1.1 TP NC + 1	Total cfm NC Side	188 - -	250 16 -	313 22 -	375 26 -	438 30 -	500 34 -	563 37 -
		A1&B1	X	188	250	313	375	438	500	563
		A2&B2	X & Y	94	125	156	188	219	250	281
	E2&F2	X	150	200	250	300	350	400	450	
		Y	38	50	63	75	88	100	113	
	A3	X	84	113	141	169	197	225	253	
		Y	19	25	31	38	44	50	56	
	E3	X	113	150	188	225	263	300	338	
		Y	38	50	63	75	88	100	113	
	B4	X	75	100	125	150	175	200	225	
		Y	19	25	31	38	44	50	56	
	6 x 18 0.75 ft²	Return Factors -SP = 1.1 TP NC + 1	Total cfm NC Side	225 - -	300 16 -	375 22 -	450 27 -	525 31 -	600 34 -	675 38 -
		A1&B1	X	225	300	375	450	525	600	675
		A2&B2	X & Y	113	150	188	225	263	300	338
E2&F2		X	188	250	313	375	438	500	563	
		Y	38	50	63	75	88	100	113	
A3		X	103	138	172	206	241	275	309	
		Y	19	25	31	38	44	50	56	
E3		X	150	200	250	300	350	400	450	
		Y	38	50	63	75	88	100	113	
B4		X	94	125	156	188	219	250	281	
		Y	19	25	31	38	44	50	56	
6 x 21 0.88 ft²		Return Factors -SP = 1.1 TP NC + 1	Total cfm NC Side	263 - -	350 17 -	438 23 -	525 27 -	613 31 -	700 35 -	788 38 -
		A1&B1	X	263	350	438	525	613	700	788
		A2&B2	X & Y	131	175	219	263	306	350	394
	E2&F2	X	225	300	375	450	525	600	675	
		Y	38	50	63	75	88	100	113	
	A3	X	122	163	203	244	284	325	366	
		Y	19	25	31	38	44	50	56	
	E3	X	188	250	313	375	438	500	563	
		Y	38	50	63	75	88	100	113	
	B4	X	113	150	188	225	263	300	338	
		Y	19	25	31	38	44	50	56	

PERFORMANCE DATA

TDC - RECTANGULAR NECK / LOUVERED FACE / SUPPLY / HORIZONTAL BLOW PATTERN

		Neck Vel. Vel. Pressure	300 0.006	400 0.010	500 0.016	600 0.022	700 0.031	800 0.040	900 0.050							
		Total Pressure	0.042	0.075	0.117	0.169	0.229	0.300	0.379							
Return Factors -SP = 1.1 TP NC + 1		Total cfm NC Side	300 -	400 17	500 23	600 28	700 32	800 35	900 38							
		cfm	Throw	cfm	Throw	cfm	Throw	cfm	Throw							
6 x 24 1.00 ft²	A1&B1	X	300	17-21-30	400	20-24-34	500	22-27-38	600	24-30-42	700	26-32-45	800	28-34-49	900	30-36-52
	A2&B2	X & Y	150	9-14-25	200	13-19-28	250	16-22-32	300	19-25-35	350	22-27-37	400	23-28-40	450	25-30-43
	E2&F2	X	263	12-16-23	350	15-19-27	438	17-21-30	525	19-23-33	613	21-25-36	700	22-27-38	788	23-28-40
		Y	38	7-11-19	50	10-15-22	63	12-18-25	75	15-19-27	88	17-21-29	100	18-22-31	113	19-23-33
	A3	X	141	11-16-22	188	14-18-26	234	17-20-29	281	18-22-31	328	20-24-34	375	21-26-36	422	22-27-38
		Y	19	7-11-17	25	10-14-20	31	12-16-22	38	14-17-24	44	15-19-26	50	16-20-28	56	17-21-30
	E3	X	225	15-19-27	300	18-22-31	375	20-24-34	450	22-27-38	525	23-29-41	600	25-31-43	675	27-33-46
		Y	38	7-11-19	50	10-15-22	63	12-18-25	75	15-19-27	88	17-21-29	100	18-22-31	113	19-23-33
B4	X	131	11-16-22	175	14-18-26	219	17-20-29	263	18-22-31	306	20-24-34	350	21-26-36	394	22-27-38	
	Y	19	7-11-17	25	10-14-20	31	12-16-22	38	14-17-24	44	15-19-26	50	16-20-28	56	17-21-30	
Return Factors -SP = 1.1 TP NC + 1		Total cfm NC Side	375 -	500 18	625 24	750 29	875 33	1000 36	1125 39							
		cfm	Throw	cfm	Throw	cfm	Throw	cfm	Throw	cfm	Throw	cfm	Throw	cfm	Throw	
6 x 30 1.25 ft²	A1&B1	X	375	19-24-33	500	22-27-38	625	25-30-43	750	27-33-47	875	29-36-51	1000	31-38-54	1125	33-41-58
	A2&B2	X & Y	188	11-16-27	250	14-21-32	313	18-25-35	375	21-27-39	438	24-30-42	500	26-32-45	563	27-34-48
	E2&F2	X	338	13-18-26	450	17-21-30	563	19-24-34	675	21-26-37	788	23-28-40	900	25-30-42	1013	26-32-45
		Y	38	8-12-21	50	11-16-25	63	14-20-28	75	16-21-30	88	19-23-33	100	20-25-35	113	21-26-37
	A3	X	178	12-18-25	238	16-20-29	297	18-23-32	356	20-25-35	416	22-27-38	475	23-29-40	534	25-30-43
		Y	19	8-12-19	25	11-16-22	31	13-18-25	38	16-19-27	44	17-21-29	50	18-22-31	56	19-24-33
	E3	X	300	17-21-30	400	20-24-34	500	22-27-38	600	24-30-42	700	26-32-45	800	28-34-49	900	30-36-51
		Y	38	8-12-21	50	11-16-25	63	14-20-28	75	16-21-30	88	19-23-33	100	20-25-35	113	21-26-37
B4	X	169	12-18-25	225	16-20-29	281	18-23-32	338	20-25-35	394	22-27-38	450	23-29-40	506	25-30-43	
	Y	19	8-12-19	25	11-16-22	31	13-18-25	38	16-19-27	44	17-21-29	50	18-22-31	56	19-24-33	
Return Factors -SP = 1.1 TP NC + 1		Total cfm NC Side	225 -	300 16	375 22	450 27	525 31	600 34	675 38							
		cfm	Throw	cfm	Throw	cfm	Throw	cfm	Throw	cfm	Throw	cfm	Throw	cfm	Throw	
9 x 12 0.75 ft²	A1&B1	X	225	15-18-26	300	17-21-30	375	19-24-33	450	21-26-36	525	23-28-39	600	24-30-42	675	26-32-45
	A2&B2	X & Y	113	8-12-21	150	10-15-22	188	14-19-27	225	16-21-30	263	19-23-32	300	20-25-35	338	21-26-37
	E2&F2	X	141	10-14-20	188	13-16-23	234	15-18-26	281	16-20-28	328	18-22-31	375	19-23-33	422	20-25-35
		Y	84	6-9-17	113	8-13-19	141	10-15-21	169	13-17-23	197	15-18-25	225	16-19-27	253	17-20-29
	A3	X	91	9-14-19	122	12-16-22	152	14-18-25	183	16-19-27	213	17-21-29	244	18-22-31	274	19-23-33
		Y	42	6-9-15	56	8-12-17	70	10-14-19	84	12-15-21	98	13-16-23	113	14-17-24	127	15-18-26
	A3-2	X	75	9-13-21	100	12-17-24	125	15-19-27	150	17-21-30	175	19-23-32	200	20-24-34	225	21-26-37
		Y	75	6-9-17	100	8-13-19	125	10-15-21	150	13-17-23	175	15-18-25	200	16-19-27	225	17-20-29
B4	X	70	9-14-19	94	12-16-22	117	14-18-25	141	16-19-27	164	17-21-29	188	18-22-31	211	19-23-33	
	Y	42	6-9-15	56	8-12-17	70	10-14-19	84	12-15-21	98	13-16-23	113	14-17-24	127	15-18-26	
Return Factors -SP = 1.1 TP NC + 1		Total cfm NC Side	281 -	375 17	469 23	563 28	656 32	750 35	844 38							
		cfm	Throw	cfm	Throw	cfm	Throw	cfm	Throw	cfm	Throw	cfm	Throw	cfm	Throw	
9 x 15 0.94 ft²	A1&B1	X	281	17-20-29	375	19-24-33	469	21-26-37	563	24-29-41	656	25-31-44	750	27-33-47	844	29-35-50
	A2&B2	X & Y	141	9-14-24	188	12-17-24	234	15-22-31	281	18-24-34	328	21-26-36	375	22-27-39	422	24-29-41
	E2&F2	X	197	12-16-23	263	15-18-26	328	17-21-29	394	18-23-32	459	20-24-34	525	21-26-37	591	23-28-39
		Y	84	7-11-19	113	9-14-21	141	12-17-24	169	14-19-26	197	16-20-28	225	18-21-30	253	19-23-32
	A3	X	120	10-15-21	159	14-18-25	199	16-20-28	239	18-21-30	279	19-23-33	319	20-25-35	359	21-26-37
		Y	42	7-10-17	56	9-14-19	70	12-15-21	84	14-17-24	98	15-18-25	113	16-19-27	127	17-20-29
	A3-2	X	117	10-15-24	156	13-19-27	195	16-22-30	234	19-24-33	273	21-25-36	313	22-27-38	352	24-29-41
		Y	82	7-11-19	109	9-14-21	137	12-17-24	164	14-19-26	191	16-20-28	219	18-21-30	246	19-23-32
B4	X	98	10-15-21	131	14-18-25	164	16-20-28	197	18-21-30	230	19-23-33	263	20-25-35	295	21-26-37	
	Y	42	7-10-17	56	9-14-19	70	12-15-21	84	14-17-24	98	15-18-25	113	16-19-27	127	17-20-29	
Return Factors -SP = 1.1 TP NC + 1		Total cfm NC Side	338 -	450 18	563 24	675 28	788 32	900 36	1013 39							
		cfm	Throw	cfm	Throw	cfm	Throw	cfm	Throw	cfm	Throw	cfm	Throw	cfm	Throw	
9 x 18 1.13 ft²	A1&B1	X	338	18-22-32	450	21-26-36	563	24-29-41	675	26-32-45	788	28-34-48	900	30-36-52	1013	32-39-55
	A2&B2	X & Y	169	10-15-26	225	13-20-30	281	17-24-34	338	20-26-37	394	23-28-40	450	25-30-43	506	26-32-45
	E2&F2	X	253	13-17-25	338	16-20-28	422	18-23-32	506	20-25-35	591	22-27-38	675	23-28-40	759	25-30-43
		Y	84	8-12-20	113	10-15-23	141	13-19-26	169	15-20-29	197	18-22-31	225	19-23-33	253	20-25-35
	A3	X	148	11-17-23	197	15-19-27	246	18-21-30	295	19-23-33	345	21-25-36	394	22-27-38	443	23-29-41
		Y	42	8-11-18	56	10-15-21	70	13-17-24	84	15-18-26	98	16-20-28	113	17-21-30	127	18-22-32
	B3	X	169	14-20-28	225	19-23-32	281	21-25-36	338	23-28-39	394	25-30-43	450	26-32-46	506	28-34-48
		Y	84	8-12-20	113	10-15-23	141	13-19-26	169	15-20-29	197	18-22-31	225	19-23-33	253	20-25-35
B4	X	127	11-17-23	169	15-19-27	211	18-21-30	253	19-23-33	295	21-25-36	338	22-27-38	380	23-29-41	
	Y	42	8-11-18	56	10-15-21	70	13-17-24	84	15-18-26	98	16-20-28	113	17-21-30	127	18-22-32	

www.titus-hvac.com

T

PERFORMANCE DATA

TDC - RECTANGULAR NECK / LOUVERED FACE / SUPPLY / HORIZONTAL BLOW PATTERN

		Neck Vel. Vel. Pressure	300 0.006	400 0.010	500 0.016	600 0.022	700 0.031	800 0.040	900 0.050		
		Total Pressure	0.042	0.075	0.117	0.169	0.229	0.300	0.379		
Return Factors -SP = 1.1 TP NC + 1	Total cfm	394	525	656	788	919	1050	1181	1312		
	NC Side	11	18	24	29	33	36	39	42		
		cfm	Throw	cfm	Throw	cfm	Throw	cfm	Throw		
9 x 21 ft²	A1&B1	X	394 20-24-34	525 23-28-39	656 25-31-44	788 28-34-48	919 30-37-52	1050 32-39-56	1181 34-42-59		
	A2&B2	X & Y	197 11-16-28	263 14-22-32	328 18-26-36	394 22-28-40	459 25-30-43	525 27-32-46	591 28-34-49		
	E2&F2	X	309 14-19-27	413 18-22-31	516 20-24-34	619 22-27-38	722 23-29-41	825 25-31-43	928 27-33-46		
		Y	84 8-12-22	113 11-17-25	141 14-20-28	169 17-22-31	197 19-24-34	225 21-25-36	253 22-27-38		
	A3	X	176 12-18-25	234 16-21-29	293 19-23-33	352 21-25-36	410 22-27-39	469 24-29-41	527 25-31-44		
		Y	42 8-12-20	56 11-16-23	70 14-18-25	84 16-20-28	98 17-21-30	113 19-23-32	127 20-24-34		
	E3	X	225 17-22-30	300 20-25-35	375 23-28-39	450 25-30-43	525 27-33-47	600 29-35-50	675 30-37-53		
		Y	84 8-12-22	113 11-17-25	141 14-20-28	169 17-22-31	197 19-24-34	225 21-25-36	253 22-27-38		
	B4	X	155 12-18-25	206 16-21-29	258 19-23-33	309 21-25-36	361 22-27-39	413 24-29-41	464 25-31-44		
		Y	42 8-12-20	56 11-16-23	70 14-18-25	84 16-20-28	98 17-21-30	113 19-23-32	127 20-24-34		
9 x 24 ft²	Return Factors -SP = 1.1 TP NC + 1		Total cfm	450	600	750	900	1050	1200	1350	
			NC Side	11	19	24	29	33	37	40	
				cfm	Throw	cfm	Throw	cfm	Throw	cfm	Throw
	9 x 24 ft²	A1&B1	X	450 21-26-36	600 24-30-42	750 27-33-47	900 30-36-52	1050 32-39-56	1200 34-42-60	1350 36-45-63	
		A2&B2	X & Y	225 12-17-30	300 15-23-35	375 19-27-39	450 23-30-43	525 27-32-46	600 28-35-49	675 30-37-52	
		E2&F2	X	366 15-20-28	488 19-23-33	609 21-26-37	731 23-28-40	853 25-31-43	975 27-33-46	1097 28-35-49	
			Y	84 9-13-23	113 12-18-27	141 15-21-30	169 18-23-33	197 21-25-36	225 22-27-38	253 23-29-41	
		A3	X	204 13-19-27	272 17-22-31	340 20-25-35	408 22-27-38	476 24-29-41	544 26-31-44	612 27-33-47	
			Y	42 9-13-21	56 12-17-24	70 15-19-27	84 17-21-30	98 19-23-32	113 20-24-34	127 21-26-36	
		E3	X	281 19-23-33	375 22-27-38	469 24-30-42	563 27-33-46	656 29-35-50	750 31-38-53	844 33-40-56	
		Y	84 9-13-23	113 12-18-27	141 15-21-30	169 18-23-33	197 21-25-36	225 22-27-38	253 23-29-41		
B4		X	183 13-19-27	244 17-22-31	305 20-25-35	366 22-27-38	427 24-29-41	488 26-31-44	548 27-33-47		
		Y	42 9-13-21	56 12-17-24	70 15-19-27	84 17-21-30	98 19-23-32	113 20-24-34	127 21-26-36		
9 x 30 ft²	Return Factors -SP = 1.1 TP NC + 1		Total cfm	563	750	938	1125	1313	1500	1688	
			NC Side	12	19	25	30	34	37	41	
				cfm	Throw	cfm	Throw	cfm	Throw	cfm	Throw
	9 x 30 ft²	A1&B1	X	563 24-29-41	750 27-33-47	938 30-37-53	1125 33-41-58	1313 36-44-62	1500 38-47-67	1688 41-50-71	
		A2&B2	X & Y	281 13-19-34	375 17-26-39	469 21-31-43	563 26-34-48	656 30-36-51	750 32-39-55	844 34-41-58	
		E2&F2	X	478 16-23-32	638 21-26-37	797 24-29-41	956 26-32-45	1116 28-34-49	1275 30-37-52	1434 32-39-55	
			Y	84 10-15-26	113 13-20-30	141 17-24-34	169 20-26-37	197 23-28-40	225 25-30-43	253 26-32-45	
		A3	X	260 14-21-30	347 19-25-35	434 23-28-39	520 25-30-43	607 27-33-46	694 29-35-50	780 30-37-53	
			Y	42 10-15-24	56 13-19-27	70 16-21-30	84 19-24-33	98 21-25-36	113 22-27-38	127 24-29-41	
		E3	X	394 21-26-36	525 24-30-42	656 27-33-47	788 30-36-51	919 32-39-56	1050 34-42-59	1181 36-45-63	
		Y	84 10-15-26	113 13-20-30	141 17-24-34	169 20-26-37	197 23-28-40	225 25-30-43	253 26-32-45		
B4		X	239 14-21-30	319 19-25-35	398 23-28-39	478 25-30-43	558 27-33-46	638 29-35-50	717 30-37-53		
		Y	42 10-15-24	56 13-19-27	70 16-21-30	84 19-24-33	98 21-25-36	113 22-27-38	127 24-29-41		
9 x 36 ft²	Return Factors -SP = 1.1 TP NC + 1		Total cfm	675	900	1125	1350	1575	1800	2025	
			NC Side	12	20	26	31	35	38	41	
				cfm	Throw	cfm	Throw	cfm	Throw	cfm	Throw
	9 x 36 ft²	A1&B1	X	675 26-32-45	900 30-36-52	1125 33-41-58	1350 36-45-63	1575 39-48-68	1800 42-52-73	2025 45-55-77	
		A2&B2	X & Y	338 14-21-37	450 19-28-43	563 24-34-48	675 28-37-52	788 32-40-56	900 35-43-60	1013 37-45-64	
		E2&F2	X	591 18-25-35	788 23-28-40	984 26-32-45	1181 28-35-49	1378 31-38-53	1575 33-40-57	1772 35-43-60	
			Y	84 11-16-29	113 15-22-33	141 18-26-37	169 22-29-41	197 25-31-44	225 27-33-47	253 29-35-50	
		A3	X	316 16-23-33	422 21-27-38	527 25-30-43	633 27-33-47	738 29-36-51	844 31-38-54	949 33-41-58	
			Y	42 11-16-26	56 14-21-30	70 18-24-33	84 21-26-36	98 23-28-39	113 24-30-42	127 26-32-45	
		E3	X	506 23-28-40	675 27-33-46	844 30-36-51	1013 33-40-56	1181 35-43-61	1350 38-46-65	1519 40-49-69	
		Y	84 11-16-29	113 15-22-33	141 18-26-37	169 22-29-41	197 25-31-44	225 27-33-47	253 29-35-50		
B4		X	295 16-23-33	394 21-27-38	492 25-30-43	591 27-33-47	689 29-36-51	788 31-38-54	886 33-41-58		
		Y	42 11-16-26	56 14-21-30	70 18-24-33	84 21-26-36	98 23-28-39	113 24-30-42	127 26-32-45		
12 x 15 ft²	Return Factors -SP = 1.1 TP NC + 1		Total cfm	375	500	625	750	875	1000	1125	
			NC Side	-	18	24	29	33	36	39	
				cfm	Throw	cfm	Throw	cfm	Throw	cfm	Throw
	12 x 15 ft²	A1&B1	X	375 19-24-33	500 22-27-38	625 25-30-43	750 27-33-47	875 29-36-51	1000 31-38-54	1125 33-41-58	
		A2&B2	X & Y	188 46707	250 14-21-32	313 18-25-35	375 21-27-39	438 24-30-42	500 26-32-45	563 27-34-48	
		E2&F2	X	225 13-18-26	300 17-21-30	375 19-24-34	450 21-26-37	525 23-28-40	600 25-30-42	675 26-32-45	
			Y	150 8-12-21	200 11-16-25	250 14-20-28	300 16-21-30	350 19-23-33	400 20-25-35	450 21-26-37	
		A3	X	150 12-18-25	200 16-20-29	250 18-23-32	300 20-25-35	350 22-27-38	400 23-29-40	450 25-30-43	
			Y	75 8-12-19	100 11-16-22	125 13-18-25	150 16-19-27	175 17-21-29	200 18-22-31	225 19-24-33	
		A3-2	X	117 11-17-27	156 15-22-31	195 19-25-35	234 22-27-38	273 24-29-42	313 26-31-44	352 27-33-47	
		Y	129 8-12-21	172 11-16-25	215 14-20-28	258 16-21-30	301 19-23-33	344 20-25-35	387 21-26-37		
B4		X	113 12-18-25	150 16-20-29	188 18-23-32	225 20-25-35	263 22-27-38	300 23-29-40	338 25-30-43		
		Y	75 8-12-19	100 11-16-22	125 13-18-25	150 16-19-27	175 17-21-29	200 18-22-31	225 19-24-33		



PERFORMANCE DATA

TDC - RECTANGULAR NECK / LOUVERED FACE / SUPPLY / HORIZONTAL BLOW PATTERN

Redefine your comfort zone.™ | www.titus-hvac.com

		Neck Vel. Vel. Pressure Total Pressure	300 0.006 0.042	400 0.010 0.075	500 0.016 0.117	600 0.022 0.169	700 0.031 0.229	800 0.040 0.300	900 0.050 0.379
12 x 18 ft²	Return Factors -SP = 1.1 TP NC + 1	Total cfm NC Side	450 11	600 19	750 24	900 29	1050 33	1200 37	1350 40
	A18B1	X	450 21-26-36	600 24-30-42	750 27-33-47	900 30-36-52	1050 32-39-56	1200 34-42-60	1350 36-45-63
	A28B2	X & Y	225 12-17-30	300 15-23-35	375 19-27-39	450 23-30-43	525 27-32-46	600 28-35-49	675 30-37-52
	E28F2	X	300 15-20-28	400 19-23-33	500 21-26-37	600 23-28-40	700 25-31-43	800 27-33-46	900 28-35-49
		Y	150 9-13-23	200 12-18-27	250 15-21-30	300 18-23-33	350 21-25-36	400 22-27-38	450 23-29-41
	A3	X	188 13-19-27	250 17-22-31	313 20-25-35	375 22-27-38	438 24-29-41	500 26-31-44	563 27-33-47
		Y	75 9-13-21	100 12-17-24	125 15-19-27	150 17-21-30	175 19-23-32	200 20-24-34	225 21-26-36
	A3-2	X	169 12-19-30	225 17-24-34	281 21-27-38	338 24-30-42	394 26-32-46	450 28-34-49	506 30-37-52
		Y	141 9-13-23	188 12-18-27	234 15-21-30	281 18-23-33	328 21-25-36	375 22-27-38	422 23-29-41
	B4	X	150 13-19-27	200 17-22-31	250 20-25-35	300 22-27-38	350 24-29-41	400 26-31-44	450 27-33-47
	Y	75 9-13-21	100 12-17-24	125 15-19-27	150 17-21-30	175 19-23-32	200 20-24-34	225 21-26-36	
12 x 21 ft²	Return Factors -SP = 1.1 TP NC + 1	Total cfm NC Side	525 12	700 19	875 25	1050 30	1225 34	1400 37	1575 40
	A18B1	X	525 23-28-39	700 26-32-45	875 29-36-51	1050 32-39-56	1225 35-43-60	1400 37-45-64	1575 39-48-68
	A28B2	X & Y	263 12-19-32	350 17-25-37	438 21-30-42	525 25-32-46	613 29-35-50	700 31-37-53	788 32-40-56
	E28F2	X	375 16-22-31	500 21-25-36	625 23-28-40	750 25-31-43	875 27-33-47	1000 29-36-50	1125 31-38-53
		Y	150 10-14-25	200 13-19-29	250 16-23-33	300 19-25-36	350 22-27-39	400 24-29-41	450 25-31-44
	A3	X	225 14-21-29	300 19-24-34	375 22-27-38	450 24-29-41	525 26-32-45	600 28-34-48	675 29-36-51
		Y	75 9-14-23	100 13-19-26	125 16-21-29	150 19-23-32	175 20-25-35	200 21-26-37	225 23-28-39
	A3-2	X	230 13-20-32	306 18-26-37	383 22-29-42	459 26-32-46	536 28-35-49	613 30-37-53	689 32-39-56
		Y	148 10-14-25	197 13-19-29	246 16-23-33	295 19-25-36	345 22-27-39	394 24-29-41	443 25-31-44
	B4	X	188 14-21-29	250 19-24-34	313 22-27-38	375 24-29-41	438 26-32-45	500 28-34-48	563 29-36-51
	Y	75 9-14-23	100 13-19-26	125 16-21-29	150 19-23-32	175 20-25-35	200 21-26-37	225 23-28-39	
12 x 24 ft²	Return Factors -SP = 1.1 TP NC + 1	Total cfm NC Side	600 12	800 20	1000 25	1200 30	1400 34	1600 38	1800 41
	A18B1	X	600 24-30-42	800 28-34-49	1000 31-38-54	1200 34-42-60	1400 37-45-64	1600 40-49-69	1800 42-52-73
	A28B2	X & Y	300 13-20-35	400 18-27-40	500 22-32-45	600 27-35-49	700 31-37-53	800 33-40-57	900 35-43-60
	E28F2	X	450 17-23-33	600 22-27-38	750 25-30-42	900 27-33-46	1050 29-36-50	1200 31-38-54	1350 33-40-57
		Y	150 10-15-27	200 14-21-31	250 17-25-35	300 21-27-38	350 24-29-41	400 26-31-44	450 27-33-47
	A3	X	263 15-22-31	350 20-26-36	438 23-29-40	525 26-31-44	613 28-34-48	700 30-36-51	788 31-38-54
		Y	75 10-15-24	100 14-20-28	125 17-22-31	150 20-24-34	175 21-26-37	200 23-28-40	225 24-30-42
	B3	X	300 19-26-37	400 25-30-43	500 28-34-48	600 30-37-53	700 33-40-57	800 35-43-61	900 37-46-65
		Y	150 10-15-27	200 14-21-31	250 17-25-35	300 21-27-38	350 24-29-41	400 26-31-44	450 27-33-47
	B4	X	225 15-22-31	300 20-26-36	375 23-29-40	450 26-31-44	525 28-34-48	600 30-36-51	675 31-38-54
	Y	75 10-15-24	100 14-20-28	125 17-22-31	150 20-24-34	175 21-26-37	200 23-28-40	225 24-30-42	
12 x 30 ft²	Return Factors -SP = 1.1 TP NC + 1	Total cfm NC Side	750 13	1000 20	1250 26	1500 31	1750 35	2000 38	2250 41
	A18B1	X	750 27-33-47	1000 31-38-54	1250 35-43-61	1500 38-47-67	1750 42-51-72	2000 44-54-77	2250 47-58-82
	A28B2	X & Y	375 15-22-39	500 20-30-45	625 25-35-50	750 30-39-55	875 34-42-59	1000 37-45-63	1125 39-48-67
	E28F2	X	600 19-26-37	800 25-30-42	1000 27-34-47	1200 30-37-52	1400 32-40-56	1600 35-42-60	1800 37-45-64
		Y	150 11-17-30	200 15-23-35	250 19-28-39	300 23-30-43	350 27-33-46	400 29-35-50	450 30-37-53
	A3	X	338 17-25-35	450 22-29-40	563 26-32-45	675 29-35-50	788 31-38-53	900 33-40-57	1013 35-43-61
		Y	75 11-17-27	100 15-22-31	125 19-25-35	150 22-27-38	175 24-29-41	200 26-31-44	225 27-33-47
	E3	X	450 24-30-42	600 28-34-49	750 31-38-54	900 34-42-59	1050 37-45-64	1200 40-49-69	1350 42-51-73
		Y	150 11-17-30	200 15-23-35	250 19-28-39	300 23-30-43	350 27-33-46	400 29-35-50	450 30-37-53
	B4	X	300 17-25-35	400 22-29-40	500 26-32-45	600 29-35-50	700 31-38-53	800 33-40-57	900 35-43-61
	Y	75 11-17-27	100 15-22-31	125 19-25-35	150 22-27-38	175 24-29-41	200 26-31-44	225 27-33-47	
12 x 36 ft²	Return Factors -SP = 1.1 TP NC + 1	Total cfm NC Side	900 13	1200 21	1500 27	1800 31	2100 36	2400 39	2700 42
	A18B1	X	900 30-36-52	1200 34-42-60	1500 38-47-67	1800 42-52-73	2100 45-56-79	2400 49-60-84	2700 52-63-89
	A28B2	X & Y	450 16-24-43	600 22-33-49	750 27-39-55	900 33-43-60	1050 37-46-65	1200 40-49-69	1350 43-52-74
	E28F2	X	750 21-28-40	1000 27-33-46	1250 30-37-52	1500 33-40-57	1750 36-43-62	2000 38-46-66	2250 40-49-70
		Y	150 13-19-33	200 17-25-38	250 21-30-43	300 25-33-47	350 29-36-51	400 31-38-54	450 33-41-58
	A3	X	413 18-27-38	550 24-31-44	688 29-35-50	825 31-38-54	963 34-41-59	1100 36-44-63	1238 38-47-66
		Y	75 12-19-30	100 17-24-34	125 21-27-38	150 24-30-42	175 26-32-45	200 28-34-49	225 30-36-52
	E3	X	600 26-33-46	800 31-38-53	1000 34-42-59	1200 38-46-65	1400 41-50-70	1600 43-53-75	1800 46-56-80
		Y	150 13-19-33	200 17-25-38	250 21-30-43	300 25-33-47	350 29-36-51	400 31-38-54	450 33-41-58
	B4	X	375 18-27-38	500 24-31-44	625 29-35-50	750 31-38-54	875 34-41-59	1000 36-44-63	1125 38-47-66
	Y	75 12-19-30	100 17-24-34	125 21-27-38	150 24-30-42	175 26-32-45	200 28-34-49	225 30-36-52	



PERFORMANCE DATA



TDC - RECTANGULAR NECK / LOUVERED FACE / SUPPLY / HORIZONTAL BLOW PATTERN

		Neck Vel. Vel. Pressure Total Pressure	300 0.006 0.042	400 0.010 0.075	500 0.016 0.117	600 0.022 0.169	700 0.031 0.229	800 0.040 0.300	900 0.050 0.379
Return Factors -SP = 1.1 TP NC + 1		Total cfm NC Side	1200 14	1600 22	2000 28	2400 32	2800 36	3200 40	3600 43
12 x 48 ft²	A1&B1	X	1200 34-42-60	1600 40-49-69	2000 44-54-77	2400 49-60-84	2800 53-64-91	3200 56-69-97	3600 60-73-103
	A2&B2	X & Y	600 19-28-49	800 25-38-57	1000 31-45-63	1200 38-49-69	1400 43-53-75	1600 46-57-80	1800 49-60-85
	E2&F2	X	1050 24-33-46	1400 31-38-54	1750 35-42-60	2100 38-46-66	2450 41-50-71	2800 44-54-76	3150 46-57-81
		Y	150 15-22-38	200 19-29-44	250 24-35-50	300 29-38-54	350 34-41-59	400 36-44-63	450 38-47-66
	A3	X	563 21-31-44	750 28-36-51	938 33-40-57	1125 36-44-63	1313 39-48-68	1500 42-51-72	1688 44-54-77
		Y	75 14-21-34	100 19-28-40	125 24-31-44	150 28-34-49	175 30-37-52	200 32-40-56	225 34-42-59
	E3	X	900 30-38-53	1200 35-43-61	1500 40-49-69	1800 43-53-75	2100 47-57-81	2400 50-61-87	2700 53-65-92
		Y	150 15-22-38	200 19-29-44	250 24-35-50	300 29-38-54	350 34-41-59	400 36-44-63	450 38-47-66
	B4	X	525 21-31-44	700 28-36-51	875 33-40-57	1050 36-44-63	1225 39-48-68	1400 42-51-72	1575 44-54-77
		Y	75 14-21-34	100 19-28-40	125 24-31-44	150 28-34-49	175 30-37-52	200 32-40-56	225 34-42-59
Return Factors -SP = 1.1 TP NC + 1		Total cfm NC Side	563 12	750 19	938 25	1125 30	1313 34	1500 37	1688 41
15 x 18 ft²	A1&B1	X	563 24-29-41	750 27-33-47	938 30-37-53	1125 33-41-58	1313 36-44-62	1500 38-47-67	1688 41-50-71
	A2&B2	X & Y	281 13-19-34	375 17-26-39	469 21-31-43	563 26-34-48	656 30-36-51	750 32-39-55	844 34-41-58
	E2&F2	X	328 16-23-32	438 21-26-37	547 24-29-41	656 28-34-49	766 32-39-55	875 36-42-59	984 39-48-67
		Y	234 10-15-26	313 13-20-30	391 17-24-34	469 20-26-37	547 23-28-40	625 25-30-43	703 26-32-45
	A3	X	223 14-21-30	297 19-25-35	371 23-28-39	445 25-30-43	520 27-33-46	594 29-35-50	668 30-37-53
		Y	117 10-15-24	156 13-19-27	195 16-21-30	234 19-24-33	273 21-25-36	313 22-27-38	352 24-29-41
	A3-2	X	169 14-21-33	225 19-27-38	281 23-30-43	338 27-33-47	394 29-36-51	450 31-38-54	506 33-41-58
		Y	197 10-15-26	263 13-20-30	328 17-24-34	394 20-26-37	459 23-28-40	525 25-30-43	591 26-32-45
	B4	X	164 14-21-30	219 19-25-35	273 23-28-39	328 25-30-43	383 27-33-46	438 29-35-50	492 30-37-53
		Y	117 10-15-24	156 13-19-27	195 16-21-30	234 19-24-33	273 21-25-36	313 22-27-38	352 24-29-41
Return Factors -SP = 1.1 TP NC + 1		Total cfm NC Side	656 12	875 20	1094 26	1313 30	1531 34	1750 38	1969 41
15 x 21 ft²	A1&B1	X	656 25-31-44	875 29-36-51	1094 33-40-57	1313 36-44-62	1531 39-48-67	1750 42-51-72	1969 44-54-76
	A2&B2	X & Y	328 14-21-36	438 19-28-42	547 23-33-47	656 28-36-51	766 32-39-55	875 34-42-59	984 36-44-63
	E2&F2	X	422 18-24-34	563 23-28-40	703 26-31-44	844 28-34-49	984 30-37-53	1125 32-40-56	1266 34-42-60
		Y	234 11-16-28	313 14-21-33	391 18-26-37	469 21-28-40	547 25-31-43	625 27-33-46	703 28-35-49
	A3	X	270 16-23-33	359 21-27-38	449 24-30-42	539 27-33-46	629 29-35-50	719 31-38-53	809 33-40-57
		Y	117 11-16-25	156 14-21-29	195 18-23-33	234 21-25-36	273 22-27-39	313 24-29-41	352 25-31-44
	A3-2	X	230 15-22-36	306 20-29-42	383 25-33-46	459 29-36-51	536 32-39-55	613 34-42-59	689 36-44-62
		Y	213 11-16-28	284 14-21-33	355 18-26-37	427 21-28-40	498 25-31-43	569 27-33-46	640 28-35-49
	B4	X	211 16-23-33	281 21-27-38	352 24-30-42	422 27-33-46	492 29-35-50	563 31-38-53	633 33-40-57
		Y	117 11-16-25	156 14-21-29	195 18-23-33	234 21-25-36	273 22-27-39	313 24-29-41	352 25-31-44
Return Factors -SP = 1.1 TP NC + 1		Total cfm NC Side	750 13	1000 20	1250 26	1500 31	1750 35	2000 38	2250 41
15 x 24 ft²	A1&B1	X	750 27-33-47	1000 31-38-54	1250 35-43-61	1500 38-47-67	1750 42-51-72	2000 44-54-77	2250 47-58-82
	A2&B2	X & Y	375 15-22-39	500 20-30-45	625 25-35-50	750 30-39-55	875 34-42-59	1000 37-45-63	1125 39-48-67
	E2&F2	X	516 19-26-37	688 25-30-42	859 27-34-47	1031 30-37-52	1203 32-40-56	1375 35-42-60	1547 37-45-64
		Y	234 11-17-30	313 15-23-35	391 19-28-39	469 23-30-43	547 27-33-46	625 29-35-50	703 30-37-53
	A3	X	316 17-25-35	422 22-29-40	527 26-32-45	633 29-35-50	738 31-38-53	844 33-40-57	949 35-43-61
		Y	117 11-17-27	156 15-22-31	195 19-25-35	234 22-27-38	273 24-29-41	313 26-31-44	352 27-33-47
	A3-2	X	300 16-24-38	400 21-31-44	500 27-35-50	600 31-38-54	700 34-42-59	800 36-44-63	900 38-47-67
		Y	225 11-17-30	300 15-23-35	375 19-28-39	450 23-30-43	525 27-33-46	600 29-35-50	675 30-37-53
	B4	X	258 17-25-35	344 22-29-40	430 26-32-45	516 29-35-50	602 31-38-53	688 33-40-57	773 35-43-61
		Y	117 11-17-27	156 15-22-31	195 19-25-35	234 22-27-38	273 24-29-41	313 26-31-44	352 27-33-47
Return Factors -SP = 1.1 TP NC + 1		Total cfm NC Side	938 13	1250 21	1563 27	1875 32	2188 36	2500 39	2813 42
15 x 30 ft²	A1&B1	X	938 30-37-53	1250 35-43-61	1563 39-48-68	1875 43-53-74	2188 46-57-80	2500 50-61-86	2813 53-64-91
	A2&B2	X & Y	469 17-25-43	625 22-33-50	781 28-40-56	938 33-43-61	1094 38-47-66	1250 41-50-71	1406 43-53-75
	E2&F2	X	703 21-29-41	938 27-34-47	1172 31-38-53	1406 34-41-58	1641 36-44-63	1875 39-47-67	2109 41-50-71
		Y	234 13-19-34	313 17-26-39	391 21-31-44	469 26-34-48	547 30-37-52	625 32-39-55	703 34-42-59
	A3	X	410 19-28-39	547 25-32-45	684 29-36-51	820 32-39-55	957 35-42-60	1094 37-45-64	1230 39-48-68
		Y	117 13-19-30	156 17-25-35	195 21-28-39	234 25-30-43	273 27-33-46	313 29-35-50	352 30-37-53
	B3	X	469 24-33-47	625 31-38-54	781 35-42-60	938 38-47-66	1094 41-50-71	1250 44-54-76	1406 47-57-81
		Y	234 13-19-34	313 17-26-39	391 21-31-44	469 26-34-48	547 30-37-52	625 32-39-55	703 34-42-59
	B4	X	352 19-28-39	469 25-32-45	586 29-36-51	703 32-39-55	820 35-42-60	938 37-45-64	1055 39-48-68
		Y	117 13-19-30	156 17-25-35	195 21-28-39	234 25-30-43	273 27-33-46	313 29-35-50	352 30-37-53

PERFORMANCE DATA

TDC - RECTANGULAR NECK / LOUVERED FACE / SUPPLY / HORIZONTAL BLOW PATTERN

Redefine your comfort zone.™ | www.titus-hvac.com

		Neck Vel. Vel. Pressure Total Pressure	300 0.006 0.042	400 0.010 0.075	500 0.016 0.117	600 0.022 0.169	700 0.031 0.229	800 0.040 0.300	900 0.050 0.379							
15 x 36 ft²	Return Factors -SP = 1.1 TP NC + 1	Total cfm NC Side	1125 14		1500 22		1875 27		2250 32		2625 36		3000 40		3375 43	
	A1&B1	X	1125	33-41-58	1500	38-47-67	1875	43-53-74	2250	47-58-82	2625	51-62-88	3000	54-67-94	3375	58-71-100
	A2&B2	X & Y	563	18-27-48	750	24-36-55	938	30-43-61	1125	36-48-67	1313	42-51-73	1500	45-55-78	1688	48-58-82
	E2&F2	X	891	23-32-45	1188	30-37-52	1484	34-41-58	1781	37-45-64	2078	40-49-69	2375	42-52-74	2672	45-55-78
		Y	234	14-21-37	313	19-28-43	391	23-34-48	469	28-37-53	547	33-40-57	625	35-43-61	703	37-45-64
	A3	X	504	20-30-43	672	27-35-50	840	32-39-55	1008	35-43-61	1176	38-46-66	1344	40-50-70	1512	43-53-74
		Y	117	14-21-33	156	18-27-38	195	23-30-43	234	27-33-47	273	29-36-51	313	31-38-54	352	33-41-58
	E3	X	656	29-36-51	875	34-42-59	1094	38-47-66	1313	42-51-73	1531	45-56-79	1750	49-59-84	1969	51-63-89
		Y	234	14-21-37	313	19-28-43	391	23-34-48	469	28-37-53	547	33-40-57	625	35-43-61	703	37-45-64
	B4	X	445	20-30-43	594	27-35-50	742	32-39-55	891	35-43-61	1039	38-46-66	1188	40-50-70	1336	43-53-74
		Y	117	14-21-33	156	18-27-38	195	23-30-43	234	27-33-47	273	29-36-51	313	31-38-54	352	33-41-58
	15 x 48 ft²	Return Factors -SP = 1.1 TP NC + 1	Total cfm NC Side	1500 15		2000 23		2500 28		3000 33		3500 37		4000 41		4500 44
A1&B1		X	1500	38-47-67	2000	44-54-77	2500	50-61-86	3000	54-67-94	3500	59-72-102	4000	63-77-109	4500	67-82-115
A2&B2		X & Y	750	21-32-55	1000	28-42-63	1250	35-50-71	1500	42-55-78	1750	48-59-84	2000	52-63-90	2250	55-67-95
E2&F2		X	1266	27-37-52	1688	35-42-60	2109	39-47-67	2531	42-52-74	2953	46-56-79	3375	49-60-85	3797	52-64-90
		Y	234	16-24-43	313	22-32-50	391	27-39-55	469	32-43-61	547	38-46-66	625	40-50-70	703	43-53-74
A3		X	691	24-35-50	922	31-40-57	1152	37-45-64	1383	40-50-70	1613	44-53-76	1844	47-57-81	2074	50-61-86
		Y	117	16-24-38	156	21-31-44	195	27-35-50	234	31-38-54	273	34-41-59	313	36-44-63	352	38-47-67
E3		X	1031	34-42-59	1375	40-49-69	1719	44-54-77	2063	49-59-84	2406	52-64-91	2750	56-69-97	3094	59-73-103
		Y	234	16-24-43	313	22-32-50	391	27-39-55	469	32-43-61	547	38-46-66	625	40-50-70	703	43-53-74
B4		X	633	24-35-50	844	31-40-57	1055	37-45-64	1266	40-50-70	1477	44-53-76	1688	47-57-81	1898	50-61-86
		Y	117	16-24-38	156	21-31-44	195	27-35-50	234	31-38-54	273	34-41-59	313	36-44-63	352	38-47-67
18 x 21 ft²		Return Factors -SP = 1.1 TP NC + 1	Total cfm NC Side	788 13		1050 20		1313 26		1575 31		1838 35		2100 39		2363 42
	A1&B1	X	788	28-34-48	1050	32-39-56	1313	36-44-62	1575	39-48-68	1838	43-52-74	2100	45-56-79	2363	48-59-84
	A2&B2	X & Y	394	15-23-40	525	20-30-46	656	25-36-51	788	30-40-56	919	35-43-61	1050	37-46-65	1181	40-49-69
	E2&F2	X	450	19-27-38	600	25-31-43	750	28-34-49	900	31-38-53	1050	33-41-58	1200	36-43-62	1350	38-46-65
		Y	338	12-18-31	450	16-24-36	563	20-28-40	675	24-31-44	788	27-34-47	900	29-36-51	1013	31-38-54
	A3	X	309	17-25-36	413	23-29-41	516	27-33-46	619	29-36-51	722	32-39-55	825	34-41-59	928	36-44-62
		Y	169	12-17-28	225	15-23-32	281	19-25-36	338	23-28-39	394	25-30-42	450	26-32-45	506	28-34-48
	A3-2	X	230	16-25-39	306	22-32-46	383	27-36-51	459	32-39-56	536	35-43-60	613	37-46-64	689	39-48-68
		Y	279	12-18-31	372	16-24-36	465	20-28-40	558	24-31-44	651	27-34-47	744	29-36-51	837	31-38-54
	B4	X	225	17-25-36	300	23-29-41	375	27-33-46	450	29-36-51	525	32-39-55	600	34-41-59	675	36-44-62
		Y	169	12-17-28	225	15-23-32	281	19-25-36	338	23-28-39	394	25-30-42	450	26-32-45	506	28-34-48
	18 x 30 ft²	Return Factors -SP = 1.1 TP NC + 1	Total cfm NC Side	1125 14		1500 22		1875 27		2250 32		2625 36		3000 40		3375 43
A1&B1		X	1125	33-41-58	1500	38-47-67	1875	43-53-74	2250	47-58-82	2625	51-62-88	3000	54-67-94	3375	58-71-100
A2&B2		X & Y	563	18-27-48	750	24-36-55	938	30-43-61	1125	36-48-67	1313	42-51-73	1500	45-55-78	1688	48-58-82
E2&F2		X	788	23-32-45	1050	30-37-52	1313	34-41-58	1575	37-45-64	1838	40-49-69	2100	42-52-74	2363	45-55-78
		Y	338	14-21-37	450	19-28-43	563	23-34-48	675	28-37-53	788	33-40-57	900	35-43-61	1013	37-45-64
A3		X	478	20-30-43	638	27-35-50	797	32-39-55	956	35-43-61	1116	38-46-66	1275	40-50-70	1434	43-53-74
		Y	169	14-21-33	225	18-27-38	281	23-30-43	338	27-33-47	394	29-36-51	450	31-38-54	506	33-41-58
A3-2		X	469	20-29-47	625	26-38-54	781	33-43-61	938	38-47-67	1094	42-51-72	1250	44-54-77	1406	47-58-82
		Y	328	14-21-37	438	19-28-43	547	23-34-48	656	28-37-53	766	33-40-57	875	35-43-61	984	37-45-64
B4		X	394	20-30-43	525	27-35-50	656	32-39-55	788	35-43-61	919	38-46-66	1050	40-50-70	1181	43-53-74
		Y	169	14-21-33	225	18-27-38	281	23-30-43	338	27-33-47	394	29-36-51	450	31-38-54	506	33-41-58

PERFORMANCE DATA

TDC - RECTANGULAR NECK / LOUVERED FACE / SUPPLY / HORIZONTAL BLOW PATTERN

		Neck Vel. Vel. Pressure Total Pressure	300 0.006 0.042	400 0.010 0.075	500 0.016 0.117	600 0.022 0.169	700 0.031 0.229	800 0.040 0.300	900 0.050 0.379
Return Factors -SP = 1.1 TP NC + 1		Total cfm NC Side	1350 15	1800 22	2250 28	2700 33	3150 37	3600 40	4050 43
18 x 36 4.50 ft²	A1&B1	X	1350 36-45-63	1800 42-52-73	2250 47-58-82	2700 52-63-89	3150 56-68-97	3600 60-73-103	4050 63-77-109
	A2&B2	X & Y	675 20-30-52	900 27-40-60	1125 33-48-67	1350 40-52-74	1575 46-56-80	1800 49-60-85	2025 52-64-90
	E2&F2	X	1013 25-35-49	1350 33-40-57	1688 37-45-64	2025 40-49-70	2363 43-53-75	2700 46-57-81	3038 49-60-85
		Y	338 15-23-41	450 21-31-47	563 26-37-53	675 31-41-58	788 36-44-62	900 38-47-66	1013 41-50-70
	A3	X	591 22-33-47	788 30-38-54	984 35-43-61	1181 38-47-66	1378 41-51-72	1575 44-54-77	1772 47-58-81
		Y	169 15-23-36	225 20-30-42	281 25-33-47	338 30-36-52	394 32-39-56	450 34-42-59	506 36-45-63
	B3	X	675 29-39-56	900 37-46-65	1125 42-51-72	1350 46-56-79	1575 49-60-85	1800 53-65-91	2025 56-68-97
		Y	338 15-23-41	450 21-31-47	563 26-37-53	675 31-41-58	788 36-44-62	900 38-47-66	1013 41-50-70
B4	X	506 22-33-47	675 30-38-54	844 35-43-61	1013 38-47-66	1181 41-51-72	1350 44-54-77	1519 47-58-81	
	Y	169 15-23-36	225 20-30-42	281 25-33-47	338 30-36-52	394 32-39-56	450 34-42-59	506 36-45-63	
Return Factors -SP = 1.1 TP NC + 1		Total cfm NC Side	1800 16	2400 23	3000 29	3600 34	4200 38	4800 41	5400 44
18 x 48 6.00 ft²	A1&B1	X	1800 42-52-73	2400 49-60-84	3000 54-67-94	3600 60-73-103	4200 64-79-111	4800 69-84-119	5400 73-89-126
	A2&B2	X & Y	900 23-35-60	1200 31-46-69	1500 38-55-78	1800 46-60-85	2100 53-65-92	2400 57-69-98	2700 60-74-104
	E2&F2	X	1463 29-40-57	1950 38-46-66	2438 42-52-74	2925 46-57-81	3413 50-62-87	3900 54-66-93	4388 57-70-99
		Y	338 18-27-47	450 24-36-54	563 30-43-61	675 36-47-66	788 41-51-72	900 44-54-77	1013 47-58-81
	A3	X	816 26-38-54	1088 34-44-63	1359 40-50-70	1631 44-54-77	1903 48-59-83	2175 51-63-89	2447 54-66-94
		Y	169 18-26-42	225 23-34-49	281 29-38-54	338 34-42-59	394 37-45-64	450 40-49-69	506 42-52-73
	E3	X	1125 37-46-65	1500 43-53-75	1875 49-59-84	2250 53-65-92	2625 57-70-99	3000 61-75-106	3375 65-80-113
		Y	338 18-27-47	450 24-36-54	563 30-43-61	675 36-47-66	788 41-51-72	900 44-54-77	1013 47-58-81
B4	X	731 26-38-54	975 34-44-63	1219 40-50-70	1463 44-54-77	1706 48-59-83	1950 51-63-89	2194 54-66-94	
	Y	169 18-26-42	225 23-34-49	281 29-38-54	338 34-42-59	394 37-45-64	450 40-49-69	506 42-52-73	
Return Factors -SP = 1.1 TP NC + 1		Total cfm NC Side	1050 14	1400 21	1750 27	2100 32	2450 36	2800 40	3150 43
21 x 24 3.50 ft²	A1&B1	X	1050 32-39-56	1400 37-45-64	1750 42-51-72	2100 45-56-79	2450 49-60-85	2800 53-64-91	3150 56-68-97
	A2&B2	X & Y	525 18-26-46	700 23-35-53	875 29-42-59	1050 35-46-65	1225 40-50-70	1400 43-53-75	1575 46-56-80
	E2&F2	X	591 22-31-43	788 29-36-50	984 32-40-56	1181 36-43-62	1378 38-47-66	1575 41-50-71	1772 43-53-75
		Y	459 14-20-36	613 18-27-41	766 23-33-46	919 27-36-51	1072 32-39-55	1225 34-41-59	1378 36-44-62
	A3	X	410 20-29-41	547 26-34-48	684 31-38-53	820 34-41-59	957 37-45-63	1094 39-48-68	1230 41-51-72
		Y	230 13-20-32	306 18-26-37	383 22-29-41	459 26-32-45	536 28-35-49	613 30-37-52	689 32-39-56
	A3-2	X	300 19-28-46	400 25-37-53	500 32-42-59	600 37-46-64	700 40-49-70	800 43-53-74	900 46-56-79
		Y	375 14-20-36	500 18-27-41	625 23-33-46	750 27-36-51	875 32-39-55	1000 34-41-59	1125 36-44-62
B4	X	295 20-29-41	394 26-34-48	492 31-38-53	591 34-41-59	689 37-45-63	788 39-48-68	886 41-51-72	
	Y	230 13-20-32	306 18-26-37	383 22-29-41	459 26-32-45	536 28-35-49	613 30-37-52	689 32-39-56	
Return Factors -SP = 1.1 TP NC + 1		Total cfm NC Side	1313 15	1750 22	2188 28	2625 33	3063 37	3500 40	3938 43
21 x 30 4.38 ft²	A1&B1	X	1313 36-44-62	1750 42-51-72	2188 46-57-80	2625 51-62-88	3063 55-67-95	3500 59-72-102	3938 62-76-108
	A2&B2	X & Y	656 20-29-51	875 26-39-59	1094 33-47-66	1313 39-51-73	1531 45-55-78	1750 48-59-84	1969 51-63-89
	E2&F2	X	853 25-34-49	1138 32-40-56	1422 36-44-63	1706 40-49-69	1991 43-53-74	2275 46-56-79	2559 49-60-84
		Y	459 15-23-40	613 20-30-46	766 25-37-52	919 30-40-57	1072 35-43-61	1225 38-46-66	1378 40-49-69
	A3	X	541 22-33-46	722 29-38-53	902 35-42-60	1083 38-46-66	1263 41-50-71	1444 44-53-76	1624 46-57-80
		Y	230 15-22-36	306 20-29-41	383 25-33-46	459 29-36-51	536 32-39-55	613 34-41-59	689 36-44-62
	A3-2	X	469 21-32-51	625 28-42-59	781 35-46-66	938 42-51-72	1094 45-55-78	1250 48-59-83	1406 51-62-88
		Y	422 15-23-40	563 20-30-46	703 25-37-52	844 30-40-57	984 35-43-61	1125 38-46-66	1266 40-49-69
B4	X	427 22-33-46	569 29-38-53	711 35-42-60	853 38-46-66	995 41-50-71	1138 44-53-76	1280 46-57-80	
	Y	230 15-22-36	306 20-29-41	383 25-33-46	459 29-36-51	536 32-39-55	613 34-41-59	689 36-44-62	
Return Factors -SP = 1.1 TP NC + 1		Total cfm NC Side	1575 15	2100 23	2625 29	3150 33	3675 37	4200 41	4725 44
21 x 36 5.25 ft²	A1&B1	X	1575 39-48-68	2100 45-56-79	2625 51-62-88	3150 56-68-97	3675 60-74-104	4200 64-79-111	4725 68-84-118
	A2&B2	X & Y	788 22-32-56	1050 29-43-65	1313 36-51-73	1575 43-56-80	1838 50-61-86	2100 53-65-92	2363 56-69-97
	E2&F2	X	1116 27-38-53	1488 36-43-62	1859 40-49-69	2231 43-53-75	2603 47-58-81	2975 50-62-87	3347 53-65-92
		Y	459 17-25-44	613 22-33-51	766 28-40-57	919 33-44-62	1072 39-47-67	1225 41-51-72	1378 44-54-76
	A3	X	673 24-36-51	897 32-41-59	1121 38-46-66	1345 41-51-72	1570 45-55-78	1794 48-59-83	2018 51-62-88
		Y	230 16-25-39	306 22-32-45	383 27-36-51	459 32-39-56	536 35-42-60	613 37-45-64	689 39-48-68
	A3-2	X	675 23-35-56	900 31-46-64	1125 39-51-72	1350 46-56-79	1575 49-60-85	1800 53-64-91	2025 56-68-97
		Y	450 17-25-44	600 22-33-51	750 28-40-57	900 33-44-62	1050 39-47-67	1200 41-51-72	1350 44-54-76
B4	X	558 24-36-51	744 32-41-59	930 38-46-66	1116 41-51-72	1302 45-55-78	1488 48-59-83	1673 51-62-88	
	Y	230 16-25-39	306 22-32-45	383 27-36-51	459 32-39-56	536 35-42-60	613 37-45-64	689 39-48-68	





PERFORMANCE DATA

Redefine your comfort zone.™ | www.titus-hvac.com

TDC - RECTANGULAR NECK / LOUVERED FACE / SUPPLY / HORIZONTAL BLOW PATTERN

		Neck Vel. Vel. Pressure Total Pressure	300 0.006 0.042	400 0.010 0.075	500 0.016 0.117	600 0.022 0.169	700 0.031 0.229	800 0.040 0.300	900 0.050 0.379
21 x 48 7.00 ft²	Return Factors -SP = 1.1 TP NC + 1	Total cfm NC Side	2100 16	2800 24	3500 29	4200 34	4900 38	5600 42	6300 45
	A1&B1	X	2100 45-56-79	2800 53-64-91	3500 59-72-102	4200 64-79-111	4900 70-85-120	5600 74-91-129	6300 79-97-136
	A2&B2	X & Y	1050 25-37-65	1400 33-50-75	1750 41-59-84	2100 50-65-92	2450 57-70-99	2800 61-75-106	3150 65-80-112
	E2&F2	X Y	1641 32-43-62 459 19-29-51	2188 41-50-71 613 26-38-59	2734 46-56-79 766 32-46-66	3281 50-62-87 919 38-51-72	3828 54-66-94 1072 45-55-78	4375 58-71-100 1225 48-59-83	4922 62-75-107 1378 51-62-88
	A3	X Y	935 28-41-59 230 19-28-45	1247 37-48-68 306 25-37-52	1559 44-53-76 383 32-41-59	1870 48-59-83 459 37-45-64	2182 52-63-89 536 40-49-69	2494 55-68-96 613 43-52-74	2805 59-72-101 689 45-56-79
	E3	X Y	1181 40-50-70 459 19-29-51	1575 47-57-81 613 26-38-59	1969 52-64-91 766 32-46-66	2363 57-70-99 919 38-51-72	2756 62-76-107 1072 45-55-78	3150 66-81-115 1225 48-59-83	3544 70-86-122 1378 51-62-88
	B4	X Y	820 28-41-59 230 19-28-45	1094 37-48-68 306 25-37-52	1367 44-53-76 383 32-41-59	1641 48-59-83 459 37-45-64	1914 52-63-89 536 40-49-69	2188 55-68-96 613 43-52-74	2461 59-72-101 689 45-56-79
	Return Factors -SP = 1.1 TP NC + 1	Total cfm NC Side	1500 15	2000 23	2500 28	3000 33	3500 37	4000 41	4500 44
	A1&B1	X	1500 38-47-67	2000 44-54-77	2500 50-61-86	3000 54-67-94	3500 59-72-102	4000 63-77-109	4500 67-82-115
	A2&B2	X & Y	750 21-32-55	1000 28-42-63	1250 35-50-71	1500 42-55-78	1750 48-59-84	2000 52-63-90	2250 55-67-95
	E2&F2	X Y	900 27-37-52 600 16-24-43	1200 35-42-60 800 22-32-50	1500 39-47-67 1000 27-39-55	1800 42-52-74 1200 32-43-61	2100 46-56-79 1400 38-46-66	2400 49-60-85 1600 40-50-70	2700 52-64-90 1800 43-53-74
	A3	X Y	600 24-35-50 300 16-24-38	800 31-40-57 400 21-31-44	1000 37-45-64 500 27-35-50	1200 40-50-70 600 31-38-54	1400 44-53-76 700 34-41-59	1600 47-57-81 800 36-44-63	1800 50-61-86 900 38-47-67
	A3-2	X Y	469 23-34-54 516 16-24-43	625 30-44-63 688 22-32-50	781 38-50-70 859 27-39-55	938 44-54-77 1031 32-43-61	1094 48-59-83 1203 38-46-66	1250 51-63-89 1375 40-50-70	1406 54-67-94 1547 43-53-74
	B4	X Y	450 24-35-50 300 16-24-38	600 31-40-57 400 21-31-44	750 37-45-64 500 27-35-50	900 40-50-70 600 31-38-54	1050 44-53-76 700 34-41-59	1200 47-57-81 800 36-44-63	1350 50-61-86 900 38-47-67
24 x 36 6.00 ft²	Return Factors -SP = 1.1 TP NC + 1	Total cfm NC Side	1800 16	2400 23	3000 29	3600 34	4200 38	4800 41	5400 44
	A1&B1	X	1800 42-52-73	2400 49-60-84	3000 54-67-94	3600 60-73-103	4200 64-79-111	4800 69-84-119	5400 73-89-126
	A2&B2	X & Y	900 23-35-60	1200 31-46-69	1500 38-55-78	1800 46-60-85	2100 53-65-92	2400 57-69-98	2700 60-74-104
	E2&F2	X Y	1200 29-40-57 600 18-27-47	1600 38-46-66 800 24-36-54	2000 42-52-74 1000 30-43-61	2400 46-57-81 1200 36-47-66	2800 50-62-87 1400 41-51-72	3200 54-66-93 1600 44-54-77	3600 57-70-99 1800 47-58-81
	A3	X Y	750 26-38-54 300 18-26-42	1000 34-44-63 400 23-34-49	1250 40-50-70 500 29-38-54	1500 44-54-77 600 34-42-59	1750 48-59-83 700 37-45-64	2000 51-63-89 800 40-49-69	2250 54-66-94 900 42-52-73
	A3-2	X Y	675 25-37-60 563 18-27-47	900 33-49-69 750 24-36-54	1125 41-54-77 938 30-43-61	1350 49-60-84 1125 36-47-66	1575 53-64-91 1313 41-51-72	1800 56-69-97 1500 44-54-77	2025 60-73-103 1688 47-58-81
	B4	X Y	600 26-38-54 300 18-26-42	800 34-44-63 400 23-34-49	1000 40-50-70 500 29-38-54	1200 44-54-77 600 34-42-59	1400 48-59-83 700 37-45-64	1600 51-63-89 800 40-49-69	1800 54-66-94 900 42-52-73
	Return Factors -SP = 1.1 TP NC + 1	Total cfm NC Side	2400 17	3200 24	4000 30	4800 35	5600 39	6400 42	7200 45
	A1&B1	X	2400 49-60-84	3200 56-69-97	4000 63-77-109	4800 69-84-119	5600 74-91-129	6400 79-97-138	7200 84-103-146
	A2&B2	X & Y	1200 27-40-69	1600 35-53-80	2000 44-63-90	2400 53-69-98	2800 61-75-106	3200 65-80-113	3600 69-85-120
	E2&F2	X Y	1800 34-46-66 600 21-31-54	2400 44-54-76 800 27-41-63	3000 49-60-85 1000 34-50-70	3600 54-66-93 1200 41-54-77	4200 58-71-100 1400 48-59-83	4800 62-76-107 1600 51-63-89	5400 66-81-114 1800 54-66-94
	A3	X Y	1050 30-44-63 300 20-30-49	1400 40-51-72 400 27-40-56	1750 47-57-81 500 34-44-63	2100 51-63-89 600 40-49-69	2450 55-68-96 700 43-52-74	2800 59-72-102 800 46-56-79	3150 63-77-108 900 49-59-84
	B3	X Y	1200 38-53-74 600 21-31-54	1600 50-61-86 800 27-41-63	2000 56-68-96 1000 34-50-70	2400 61-74-105 1200 41-54-77	2800 66-80-114 1400 48-59-83	3200 70-86-122 1600 51-63-89	3600 74-91-129 1800 54-66-94
	B4	X Y	900 30-44-63 300 20-30-49	1200 40-51-72 400 27-40-56	1500 47-57-81 500 34-44-63	1800 51-63-89 600 40-49-69	2100 55-68-96 700 43-52-74	2400 59-72-102 800 46-56-79	2700 63-77-108 900 49-59-84
30 x 36 7.50 ft²	Return Factors -SP = 1.1 TP NC + 1	Total cfm NC Side	2250 16	3000 24	3750 30	4500 34	5250 39	6000 42	6750 45
	A1&B1	X	2250 47-58-82	3000 54-67-94	3750 61-74-105	4500 67-82-115	5250 72-88-125	6000 77-94-133	6750 82-100-141
	A2&B2	X & Y	1125 26-39-67	1500 34-51-78	1875 43-61-87	2250 51-67-95	2625 59-73-103	3000 63-78-110	3375 67-82-116
	E2&F2	X Y	1313 33-45-64 938 20-30-53	1750 42-52-74 1250 27-40-61	2188 47-58-82 1563 33-48-68	2625 52-64-90 1875 40-53-74	3063 56-69-97 2188 46-57-80	3500 60-74-104 2500 50-61-86	3938 64-78-110 2813 53-64-91
	A3	X Y	891 29-43-61 469 20-29-47	1188 38-50-70 625 26-38-54	1484 45-55-78 781 33-43-61	1781 50-61-86 938 38-47-67	2078 53-66-93 1094 41-51-72	2375 57-70-99 1250 44-54-77	2672 61-74-105 1406 47-58-81
	A3-2	X Y	775 28-42-67 688 20-30-53	900 37-54-77 1050 27-40-61	1125 46-61-86 1125 33-48-68	1350 54-67-94 1575 40-53-74	1575 59-72-102 1800 63-77-109	1800 63-77-109 2100 50-61-86	2025 67-82-115 2363 53-64-91
	B4	X Y	656 29-43-61 469 20-29-47	875 38-50-70 625 26-38-54	1094 45-55-78 781 33-43-61	1313 50-61-86 938 38-47-67	1531 53-66-93 1094 41-51-72	1750 57-70-99 1250 44-54-77	1969 61-74-105 1406 47-58-81

PERFORMANCE DATA

TDC - RECTANGULAR NECK / LOUVERED FACE / SUPPLY / HORIZONTAL BLOW PATTERN

		Neck Vel. Vel. Pres. Total Pres.	300 0.006 0.042	400 0.010 0.075	500 0.016 0.117	600 0.022 0.169	700 0.031 0.229	800 0.040 0.300	900 0.050 0.379
Return Factors -SP = 1.1 TP NC + 1	Total cfm	3000	4000	5000	6000	7000	8000	9000	
	NC Side	17	25	31	35	39	43	46	
30 x 48 10.00 ft <sup>2</sup>	A1&B1	X	3000 54-67-94	4000 63-77-109	5000 70-86-122	6000 77-94-133	7000 83-102-144	8000 89-109-154	9000 94-115-163
	A2&B2	X & Y	1500 30-45-78	2000 40-59-90	2500 50-71-100	3000 59-78-110	3500 68-84-119	4000 73-90-127	4500 78-95-134
	E2&F2	X	2063 38-52-74	2750 49-60-85	3438 55-67-95	4125 60-74-104	4813 65-79-112	5500 69-85-120	6188 74-90-127
		Y	938 23-34-61	1250 31-46-70	1563 38-55-78	1875 46-61-86	2188 53-66-93	2500 57-70-99	2813 61-74-105
	A3	X	1266 33-50-70	1688 44-57-81	2109 52-64-90	2531 57-70-99	2953 62-76-107	3375 66-81-114	3797 70-86-121
		Y	469 23-34-54	625 30-44-63	781 38-50-70	938 44-54-77	1094 48-59-83	1250 51-63-89	1406 54-67-94
	A3-2	X	1200 32-48-77	1600 43-63-89	2000 53-70-99	2400 63-77-109	2800 68-83-118	3200 73-89-126	3600 77-94-133
		Y	900 23-34-61	1200 31-46-70	1500 38-55-78	1800 46-61-86	2100 53-66-93	2400 57-70-99	2700 61-74-105
	B4	X	1031 33-50-70	1375 44-57-81	1719 52-64-90	2063 57-70-99	2406 62-76-107	2750 66-81-114	3094 70-86-121
		Y	469 23-34-54	625 30-44-63	781 38-50-70	938 44-54-77	1094 48-59-83	1250 51-63-89	1406 54-67-94
	Return Factors -SP = 1.1 TP NC + 1	Total cfm	3600	4800	6000	7200	8400	9600	10800
		NC Side	18	25	31	36	40	44	47
36 x 48 12.00 ft <sup>2</sup>	A1&B1	X	3600 60-73-103	4800 69-84-119	6000 77-94-133	7200 84-103-146	8400 91-111-158	9600 97-119-168	10800 103-126-179
	A2&B2	X & Y	1800 33-49-85	2400 43-65-98	3000 54-78-110	3600 65-85-120	4200 75-92-130	4800 80-98-139	5400 85-104-147
	E2&F2	X	2250 42-57-81	3000 54-66-93	3750 60-74-104	4500 66-81-114	5250 71-87-123	6000 76-93-131	6750 81-99-139
		Y	1350 25-38-66	1800 34-50-77	2250 42-61-86	2700 50-66-94	3150 59-72-101	3600 63-77-108	4050 66-81-115
	A3	X	1463 37-54-77	1950 49-63-89	2438 57-70-99	2925 63-77-108	3413 68-83-117	3900 72-89-125	4388 77-94-133
		Y	675 25-37-59	900 33-49-69	1125 41-54-77	1350 49-59-84	1575 52-64-91	1800 56-69-97	2025 59-73-103
	A3-2	X	1200 35-53-84	1600 47-69-97	2000 59-77-109	2400 69-84-119	2800 74-91-129	3200 80-97-138	3600 84-103-146
		Y	1200 25-38-66	1600 34-50-77	2000 42-61-86	2400 50-66-94	2800 59-72-101	3200 63-77-108	3600 66-81-115
	B4	X	1125 37-54-77	1500 49-63-89	1875 57-70-99	2250 63-77-108	2625 68-83-117	3000 72-89-125	3375 77-94-133
		Y	675 25-37-59	900 33-49-69	1125 41-54-77	1350 49-59-84	1575 52-64-91	1800 56-69-97	2025 59-73-103

PERFORMANCE DATA

Redefine your comfort zone.™ | www.titus-hvac.com

TDC - ROUND NECK / LOUVERED FACE / SUPPLY / HORIZONTAL BLOW PATTERN

Return Factors -SP = 1.1 TP NC + 1		Total cfm Total Pressure NC Side	78 0.058 10	98 0.092 16	117 0.131 21	137 0.179 25	156 0.223 28	176 0.296 31	215 0.442 36							
		cfm	Throw	cfm	Throw	cfm	Throw	cfm	Throw							
6 x 6 6" Round	S1	X	75	5-7-15	98	6-9-18	117	7-11-20	137	9-13-22	156	10-15-25	176	45978	215	14-19-27
	S2&G2	X & Y	38	3-5-10	50	4-6-13	59	5-7-14	69	6-9-16	78	7-10-17	88	7-11-18	108	9-14-20
	A3	X	29	3-4-8	37	3-5-9	44	4-6-10	51	5-7-10	59	6-8-11	66	6-8-12	81	7-9-13
		Y	20	2-4-7	25	3-5-8	29	4-6-9	34	4-7-9	39	5-7-10	44	6-7-12	54	7-8-12
	A4	X & Y	20	2-4-7	25	3-5-8	29	4-6-9	34	4-7-9	39	5-7-10	44	6-7-12	54	7-8-12
Return Factors -SP = 1.1 TP NC + 1		Total cfm Total Pressure NC Side	98 0.041 10	117 0.058 14	137 0.079 18	156 0.103 21	176 0.131 25	215 0.196 30	254 0.273 34							
		cfm	Throw	cfm	Throw	cfm	Throw	cfm	Throw							
9 x 9 6" Round	S1	X	98	6-9-18	117	7-11-20	137	9-15-22	156	10-15-23	176	11-17-25	215	20-24-34	254	17-21-30
	S2&G2	X & Y	49	4-6-13	59	5-7-14	69	6-9-16	78	7-10-17	88	7-11-18	108	9-14-20	127	11-15-21
	A3	X	37	3-5-9	44	4-6-10	51	5-7-10	59	6-8-11	66	6-8-12	81	7-9-13	95	8-10-14
		Y	25	3-5-8	29	4-6-9	34	4-7-9	39	5-7-10	44	6-7-11	54	7-8-12	64	7-9-13
	A4	X & Y	25	3-5-8	29	4-6-9	34	4-7-9	39	5-7-10	44	6-7-11	54	7-8-12	64	7-9-13
Return Factors -SP = 1.1 TP NC + 1		Total cfm Total Pressure NC Side	139 0.046 10	174 0.072 16	209 0.104 20	244 0.142 24	279 0.186 27	314 0.235 32	383 0.350 36							
		cfm	Throw	cfm	Throw	cfm	Throw	cfm	Throw							
9 x 9 8" Round	S1	X	139	7-10-21	174	8-13-24	209	10-15-27	244	12-18-29	279	14-21-31	314	15-23-33	383	19-26-37
	S2&G2	X & Y	70	4-7-14	87	5-8-17	105	7-10-19	122	8-12-21	140	9-14-22	157	10-15-24	192	12-19-26
	A3	X	52	4-6-11	66	5-7-12	79	6-9-13	92	7-10-14	105	8-10-14	119	9-11-16	145	10-12-18
		Y	35	3-5-9	44	4-7-11	52	5-8-12	61	6-9-13	70	7-9-14	79	8-10-14	96	9-11-16
	A4	X & Y	35	3-5-9	44	4-7-11	52	5-8-12	61	6-9-13	70	7-9-14	79	8-10-14	96	9-11-16
Return Factors -SP = 1.1 TP NC + 1		Total cfm Total Pressure NC Side	174 0.041 11	209 0.059 16	244 0.080 21	279 0.104 25	314 0.132 28	383 0.197 31	453 0.275 36							
		cfm	Throw	cfm	Throw	cfm	Throw	cfm	Throw							
12 x 12 8" Round	S1	X	174	8-13-24	209	10-15-27	244	12-18-29	279	14-21-31	314	15-23-33	383	19-26-37	453	22-28-40
	S2&G2	X & Y	87	5-8-17	105	7-10-19	122	8-12-21	140	9-14-22	157	10-15-24	192	12-19-26	227	15-20-29
	A3	X	66	5-7-12	79	6-9-13	92	7-10-14	105	8-11-15	119	9-11-16	145	10-12-18	171	11-14-19
		Y	44	4-7-11	52	5-8-12	61	6-9-13	70	7-9-14	79	8-10-14	96	9-11-16	113	10-12-18
	A4	X & Y	44	4-7-11	52	5-8-12	61	6-9-13	70	7-9-14	79	8-10-14	96	9-11-16	113	10-12-18
Return Factors -SP = 1.1 TP NC + 1		Total cfm Total Pressure NC Side	218 0.041 10	272 0.064 16	327 0.092 21	381 0.125 25	436 0.163 28	490 0.206 31	599 0.308 36							
		cfm	Throw	cfm	Throw	cfm	Throw	cfm	Throw							
12 x 12 12" Round	S1	X	218	8-13-24	272	11-16-31	327	13-19-34	381	15-23-36	436	17-26-39	490	19-29-41	599	24-32-46
	S2&G2	X & Y	109	5-8-17	136	7-11-22	164	8-12-24	191	10-15-26	218	11-17-28	245	13-19-30	300	16-23-33
	A3	X	82	5-7-12	103	6-9-13	123	7-11-16	144	8-12-18	165	10-13-29	185	11-14-20	226	13-16-22
		Y	55	4-7-11	68	5-8-12	82	7-10-15	95	8-11-16	109	9-12-17	123	10-13-18	150	11-14-20
	A4	X & Y	55	4-7-11	68	5-8-12	82	7-10-15	95	8-11-16	109	9-12-17	123	10-13-18	150	11-14-20
Return Factors -SP = 1.1 TP NC + 1		Total cfm Total Pressure NC Side	235 0.033 5	314 0.059 13	392 0.092 19	471 0.132 24	549 0.130 28	628 0.235 32	706 0.298 35							
		cfm	Throw	cfm	Throw	cfm	Throw	cfm	Throw							
12 x 12 12" Round	S1	X	235	7-11-23	314	10-15-31	392	13-19-34	471	15-23-36	549	18-27-44	628	21-31-47	706	23-35-40
	S2&G2	X & Y	118	5-7-15	157	7-10-21	196	8-12-24	236	10-15-26	275	12-18-32	314	13-19-30	353	16-23-33
	A3	X	89	4-6-13	119	6-10-20	148	7-11-16	178	8-12-18	207	10-15-21	237	11-14-20	267	13-16-24
		Y	59	4-6-12	79	5-8-12	98	7-10-15	118	8-11-16	137	9-12-17	157	11-14-21	177	12-15-22
	A4	X & Y	59	4-6-12	79	5-8-12	98	7-10-15	118	8-11-16	137	9-12-17	157	11-14-21	177	12-15-22
Return Factors -SP = 1.1 TP NC + 1		Total cfm Total Pressure NC Side	314 0.038 10	392 0.059 17	471 0.085 22	549 0.115 26	623 0.150 29	706 0.190 32	863 0.284 37							
		cfm	Throw	cfm	Throw	cfm	Throw	cfm	Throw							
15 x 15 15" Round	S1	X	314	10-15-31	392	13-19-37	471	15-23-41	549	18-27-44	623	21-31-47	706	23-35-50	863	29-39-55
	S2&G2	X & Y	157	7-10-21	196	8-13-26	236	10-15-29	275	12-18-32	312	14-21-34	353	15-23-36	432	19-28-40
	A3	X	119	6-9-16	148	7-11-18	178	9-13-20	207	10-15-21	235	12-16-23	267	13-17-24	326	15-19-27
		Y	79	5-8-14	98	7-10-16	118	8-12-18	137	9-14-21	156	11-14-21	177	12-15-22	216	14-17-24
	A4	X & Y	79	5-8-14	98	7-10-16	118	8-12-18	137	9-14-21	156	11-14-21	177	12-15-22	216	14-17-24
Return Factors -SP = 1.1 TP NC + 1		Total cfm Total Pressure NC Side	320 0.029 -	427 0.051 14	534 0.080 20	641 0.115 25	748 0.157 29	855 0.205 33	863 0.260 36							
		cfm	Throw	cfm	Throw	cfm	Throw	cfm	Throw							
15 x 15 14" Round	S1	X	320	9-13-27	427	12-18-37	534	15-23-43	641	18-27-47	748	21-32-52	855	24-37-55	863	24-32-46
	S2&G2	X & Y	160	6-9-18	214	8-12-24	267	10-15-31	321	12-18-34	374	14-27-37	428	16-24-40	432	16-23-39
	A3	X	121	5-8-16	161	7-10-19	202	9-14-21	242	10-16-23	282	12-18-25	323	14-19-27	326	13-16-22
		Y	80	4-7-14	107	6-9-17	134	8-12-19	160	9-14-23	187	11-16-23	214	13-17-24	216	14-18-26
	A4	X & Y	80	4-7-14	107	6-9-17	134	8-12-19	160	9-14-23	187	11-16-23	214	13-17-24	216	14-18-26



PERFORMANCE DATA

TDC - ROUND NECK / LOUVERED FACE / SUPPLY / HORIZONTAL BLOW PATTERN

Return Factors -SP = 1.1 TP NC + 1		Total cfm Total Pressure NC Side	98 0.041 -	117 0.058 14	137 0.079 18	156 0.103 21	176 0.131 25	215 0.196 30	254 0.273 34
			cfm Throw	cfm Throw	cfm Throw	cfm Throw	cfm Throw	cfm Throw	cfm Throw
18 x 18 6" Round	S1	X	98 6-9-18	117 7-11-20	137 9-15-22	156 10-15-23	176 11-17-25	215 20-24-34	254 17-21-30
	S2&G2	X & Y	49 4-6-13	59 5-7-14	69 6-9-16	78 7-10-17	88 7-11-18	108 9-14-20	127 11-15-21
	A3	X	37 3-5-9	44 4-6-10	51 5-7-10	59 6-8-11	66 6-8-12	81 7-9-13	95 8-10-14
	Y	25 3-5-8	29 4-6-9	34 4-7-9	39 5-7-10	44 6-7-11	54 7-8-12	64 7-9-13	
Round	A4	X & Y	25 3-5-8	29 4-6-9	34 4-7-9	39 5-7-10	44 6-7-11	54 7-8-12	64 7-9-13
Return Factors -SP = 1.1 TP NC + 1		Total cfm Total Pressure NC Side	174 0.041 11	209 0.059 16	244 0.080 20	279 0.104 24	314 0.132 27	383 0.197 32	453 0.275 36
			cfm Throw	cfm Throw	cfm Throw	cfm Throw	cfm Throw	cfm Throw	cfm Throw
18 x 18 8" Round	S1	X	174 8-13-24	209 10-15-27	244 12-18-29	279 14-21-31	314 15-23-33	383 19-26-37	453 22-28-40
	S2&G2	X & Y	87 5-8-17	105 7-10-19	122 8-12-24	140 9-14-22	157 10-15-24	192 12-19-26	227 15-20-29
	A3	X	66 5-7-12	79 6-9-13	92 7-10-14	105 8-11-15	119 9-11-16	145 10-12-18	171 11-14-19
	Y	44 4-7-11	52 5-8-12	61 6-9-13	70 7-9-14	79 8-10-14	96 9-11-16	113 10-12-18	
Round	A4	X & Y	44 4-7-11	52 5-8-12	61 6-9-13	70 7-9-14	79 8-10-14	96 9-11-16	113 10-12-18
Return Factors -SP = 1.1 TP NC + 1		Total cfm Total Pressure NC Side	218 0.041 10	272 0.064 16	327 0.092 21	381 0.125 25	436 0.163 28	490 0.206 31	599 0.308 36
			cfm Throw	cfm Throw	cfm Throw	cfm Throw	cfm Throw	cfm Throw	cfm Throw
18 x 18 10" Round	S1	X	218 8-13-24	272 11-16-31	327 13-19-34	381 15-23-36	436 17-26-39	490 19-29-41	599 24-32-46
	S2&G2	X & Y	109 5-8-17	136 7-11-22	164 8-12-24	191 10-15-26	218 11-17-28	245 13-19-30	300 16-23-33
	A3	X	82 5-7-12	103 6-9-13	123 7-11-16	144 8-12-18	165 10-13-29	185 11-14-20	226 13-16-22
	Y	55 4-7-11	68 5-8-12	82 7-10-15	95 8-11-16	109 9-12-17	123 10-13-18	150 11-14-20	
Round	A4	X & Y	55 4-7-11	68 5-8-12	82 7-10-15	95 8-11-16	109 9-12-17	123 10-13-18	150 11-14-20
Return Factors -SP = 1.1 TP NC + 1		Total cfm Total Pressure NC Side	314 0.038 10	392 0.059 17	471 0.085 22	549 0.115 26	623 0.150 29	706 0.190 32	863 0.284 37
			cfm Throw	cfm Throw	cfm Throw	cfm Throw	cfm Throw	cfm Throw	cfm Throw
18 x 18 12" Round	S1	X	314 10-15-31	392 13-19-37	471 15-23-41	549 18-27-44	623 21-31-47	706 23-35-50	863 29-39-55
	S2&G2	X & Y	157 7-10-21	196 8-13-26	236 10-15-29	275 12-18-32	312 14-21-34	353 15-23-36	432 19-28-40
	A3	X	119 6-9-16	148 7-11-18	178 9-13-20	207 10-15-21	235 12-16-23	267 13-17-24	326 15-19-27
	Y	79 5-8-14	98 7-10-16	118 8-12-18	137 9-14-21	156 11-14-21	177 12-15-22	216 14-17-24	
Round	A4	X & Y	79 5-8-14	98 7-10-16	118 8-12-18	137 9-14-21	156 11-14-21	177 12-15-22	216 14-17-24
Return Factors -SP = 1.1 TP NC + 1		Total cfm Total Pressure NC Side	427 0.036 12	534 0.056 17	641 0.080 22	748 0.109 26	855 0.142 30	962 0.180 33	1175 0.269 38
			cfm Throw	cfm Throw	cfm Throw	cfm Throw	cfm Throw	cfm Throw	cfm Throw
18 x 18 14" Round	S1	X	427 12-18-27	534 15-23-43	641 18-27-47	748 21-32-47	855 27-37-55	962 27-41-58	1175 33-45-64
	S2&G2	X & Y	214 8-12-24	267 10-15-31	321 12-18-34	374 14-27-37	428 16-24-40	481 18-27-42	588 22-33-47
	A3	X	161 7-10-19	202 8-13-21	242 10-16-23	282 12-18-25	323 14-19-27	363 16-20-29	444 18-22-32
	Y	107 6-9-17	134 8-12-19	160 9-14-21	187 11-16-23	214 13-17-24	241 14-18-26	294 16-20-29	
Round	A4	X & Y	107 6-9-17	134 8-12-19	160 9-14-21	187 11-16-23	214 13-17-24	241 14-18-26	294 16-20-29
Return Factors -SP = 1.1 TP NC + 1		Total cfm Total Pressure NC Side	418 0.020 -	558 0.036 12	698 0.056 17	837 0.080 21	977 0.109 29	1116 0.142 34	1256 0.180 38
			cfm Throw	cfm Throw	cfm Throw	cfm Throw	cfm Throw	cfm Throw	cfm Throw
18 x 18 16" Round	S1	X	418 10-15-31	558 14-21-42	698 17-26-49	837 21-31-54	977 24-37-59	1116 28-42-63	1256 31-47-67
	S2&G2	X & Y	209 7-10-21	279 9-14-28	349 11-17-35	419 14-21-39	489 16-24-42	558 18-28-45	628 21-31-48
	A3	X	158 6-10-20	211 8-12-22	264 10-15-24	316 12-18-27	369 14-20-29	421 16-22-31	474 18-23-33
	Y	105 5-8-17	140 7-11-19	175 9-14-22	209 11-17-24	244 13-18-26	279 15-19-28	314 17-21-29	
Round	A4	X & Y	105 5-8-17	140 7-11-19	175 9-14-22	209 11-17-24	244 13-18-26	279 15-19-28	314 17-21-29



PERFORMANCE DATA

Redefine your comfort zone.™ | www.titus-hvac.com

PERFORMANCE NOTES

Available Models: TDC, TDC-AA, TDCA, TDCA-AA, TDV, TDV-AA

- All pressures are in inches of water. TP is total pressure, - SP is negative static pressure for return units.
- Throw values are given for terminal velocities of 150, 100, and 50 fpm. For an explanation of catalog throw data, see the section, Engineering Guidelines for catalog throw data.
- NC values are based on a room absorption of 10 dB, re 10<sup>-12</sup> watts, with one diffuser operating.
- If the diffuser is used as a return inlet, the following corrections apply:
  - Negative static pressure: Multiply the factor at the upper left corner of the performance table by the total pressure listed in the table
  - Sound: Add the NC correction at the upper left corner of the performance table to the NC value listed in the table
  - Return Performance Example: 6 x 6 Model TDC handling:  
150 cfm of return air  
-SP = 1.1(-TP).  
Return negative SP = 1.1 x (0.169) = - 0.1859 inches wg.  
Return NC = NC Table + 1  
Return NC = 23 + 1 = 24
- These products have been tested per ANSI/ASHRAE 70-2006. Actual performance, with flexible duct inlet, may vary in the field. See the section, Engineering Guidelines for additional information.
- Data in the tables apply when the diffuser is mounted nearly flush with the ceiling for maximum ceiling effect. When no ceiling effect is present, the horizontal throw will be about 25% less than shown in the tables. The mounting distance below the ceiling will also affect the downward projection angle as indicated in the diagram at upper right.

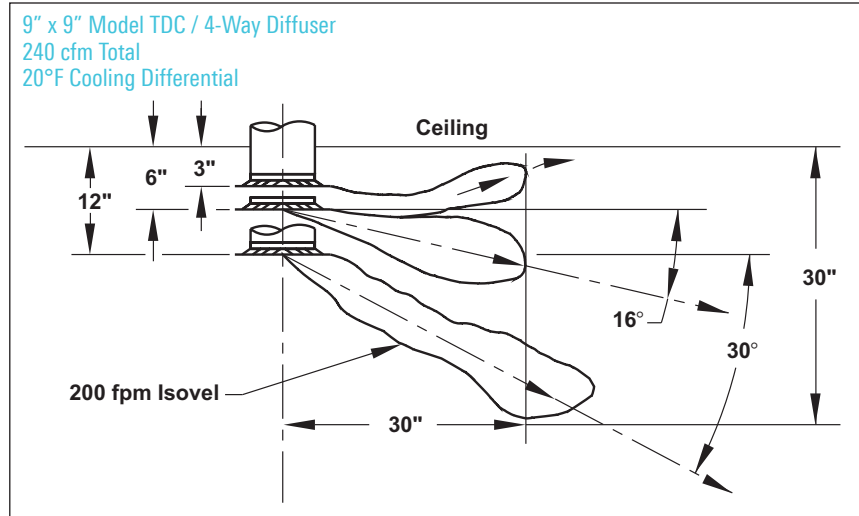

RECOMMENDED MAXIMUM AIRFLOW

Ceiling Height, ft.	8	9	10	12	15	20
Airflow, cfm, per Side	200	350	550	900	1500	4000

Note: Although this data is based on a 20°F temperature differential during cooling, it also applies to any differential between 15°F and 25°F

CORRECTIONS FOR MODEL TDCA (ADJUSTABLE PATTERN CONTROLLERS)

Nominal Neck Size	NC (add)		Total Pressure (Multiply)		Vertical Throw (Multiply)		
					Cooling 20 F	Heating, ΔT	
	H	V	H	V		0 F	20 F
6 x 6	3	7	1.3	1.6	1.3	1.1	0.8
9 x 9	3	7	1.5	2.3	1.4	1.2	0.72
12 x 12	3	7	1.5	2.3	1.5	1.25	0.65
15 x 15	3	7	1.5	2.3	1.55	1.27	0.62
18 x 18	3	7	1.5	2.3	1.6	1.3	0.59
21 x 21	3	7	1.5	2.3	1.65	1.35	0.57
24 x 24	3	7	1.5	2.3	1.1	1.1	0.55

Note: TDC and TDV Performance Data were obtained from tests conducted in accordance with ANSI/ASHRAE Standard 70-2006

- Vertical adjustments are most effective with the above sizes, using an A4 pattern
- Vertical throw will not work with round inlets

MODEL TDCA PERFORMANCE

- For Model TDCA diffusers (adjustable pattern controllers) apply the corrections from the table at the right to the TDC data for square neck, 4-way core styles, as follows:
  - TP = Listed value x correction
  - NC = Listed value + correction
  - Throw = Listed value x correction

Apply the throw factor to the 50 fpm terminal velocity throw only.

